

## Safety Precautions

- Important Notes on exporting this product or equipment containing this product;  
If the end-user or application of this product is related to military affairs or weapons, its export may be controlled by "Foreign Exchange and Foreign Trade Control Law" of Japan where export license will be required before product can be exported from Japan.
- This product is designed and manufactured for use in General Purpose Industrial Equipment and it is not intended to be used in equipment or system that may cause personal injury or death.
- All servicing such as installation, wiring, operation, maintenance and etc., should be performed by qualified personnel only.
- Tighten mounting screws with an adequate torque by taking into consideration strength of the screws and the characteristics of material to which the product will be mounted. Over tightening can damage the screw and/or material; under tightening can result in loosening.  
\*Example: apply 2.7 – 3.3 N·m torque when tightening steel screw (M5) to steel surface.
- Install safety equipment to prevent serious accidents or loss that is expected in case of failure of this product.
- Consult us before using this product under such special conditions and environments as nuclear energy control, aerospace, transportation, medical equipment, various safety equipments or equipments which require a lesser air contamination.
- We have been making the best effort to ensure the highest quality of our products, however, some applications with exceptionally large external noise disturbance and static electricity, or failure in input power, wiring and components may result in unexpected action. It is highly recommended that you make a fail-safe design and secure the safety in the operative range.
- If the motor shaft is not electrically grounded, it may cause an electrolytic corrosion to the bearing, depending on the condition of the machine and its mounting environment, and may result in the bearing noise. Checking and verification by customer is required.
- Failure of this product depending on its content may generate smoke of about one cigarette. Take this into consideration when the application of the machine is clean room related.
- Please be careful when using the product in an environment with high concentrations of sulfur or sulfuric gases, as sulfuration can lead to disconnection from the chip resistor or a poor contact connection.
- Do not input a supply voltage which significantly exceeds the rated range to the power supply of this product. Failure to heed this caution may lead to damage of the internal parts, causing smoke and/or fire and other troubles.
- The user is responsible for matching between machine and components in terms of configuration, dimensions, life expectancy, characteristics, when installing the machine or changing specification of the machine. The user is also responsible for complying with applicable laws and regulations.
- Manufacturer's warranty will be invalid if the product has been used outside its stated specifications.
- Component parts are subject to minor change to improve performance.
- Read and observe the instruction manual to ensure correct use of the product.

**Repair** Consult to the dealer from whom you have purchased this product for details of repair work.  
When the product is incorporated to the machine you have purchased, consult to the machine manufacturer or its dealer.

**URL** Electric data of this product (Instruction Manual, CAD data) can be download from the following web site;  
<[http://industrial.panasonic.com/ww/i\\_e/25000/motor\\_fa\\_e/motor\\_fa\\_e.html](http://industrial.panasonic.com/ww/i_e/25000/motor_fa_e/motor_fa_e.html)>

Contact to :

Panasonic Corporation,  
Appliances Company,  
Motor Business Division

1-1 Morofuku 7-chome, Daito, Osaka 574-0044, Japan  
Tel : +81-72-871-1212  
Fax: +81-72-870-3151



ISO14001 Certificate division  
CERTIFICATE OF APPROVAL ISO14001



ISO9001 Certificate division  
CERTIFICATE OF APPROVAL ISO9001

The contents of this catalog apply  
to the products as of July 2013.

- Printed colors may be slightly different from the actual products.
- Specifications and design of the products are subject to change without notice for the product improvement.
- This product is for industrial equipment. Don't use this product at general household.

<13.07>

Panasonic

# Panasonic

AC Servo  
MINAS A5 II / A5 series  
MINAS E series

2013/7  
Catalog

AC Servo <MINAS A5II / A5 series, E series>



# MINAS A5 Family

Panasonic Corporation, Appliances Company, Motor Business Division

[http://industrial.panasonic.com/ww/i\\_e/25000/motor\\_fa\\_e/motor\\_fa\\_e.html](http://industrial.panasonic.com/ww/i_e/25000/motor_fa_e/motor_fa_e.html)

- This product is for industrial equipment. Don't use this product at general household.

2013/7

# Servo motor that brings out potential of the machine. MINAS A5 Family



Two-degree-of-freedom control system  
**All-in-one type**

## A5II series

Rated output: **50 W to 15.0 kW**

- 20 bit incremental encoder, 17 bit absolute/ incremental encoder
- All-in-one: Speed, Position, Torque<sup>\*1</sup>, Full-closed<sup>1</sup> control type

<sup>\*1</sup> Not applicable to two-degree-of-freedom control system.

**All-in-one type**

## A5 series

Rated output: **50 W to 15.0 kW**

- 20 bit incremental encoder, 17 bit absolute/ incremental encoder
- All-in-one: Speed, Position, Torque, Full-closed control type

Two-degree-of-freedom control system  
**Position control type**

## A5IIE series

Rated output: **50 W to 5.0 kW**

- 20 bit incremental encoder
- Position control (pulse train commands)

**Position control type**

## A5E series

Rated output: **50 W to 5.0 kW**

- 20 bit incremental encoder
- Position control (pulse train commands)

Slim design and position control type

## E series



Rated output: **50 W to 400 W**

- Ultra-small design and pulse train command type only
- Real-time auto gain tuning
- DIN-rail mountable (using mounting Kit)

Linear motor and DD motor control type

## A5L series



Capacity of applying Linear motor:

**Compatible with 5.0 kW rotaly AC servo motor**

- Position, Speed, Thrust control
- Drastically reduced setup time by automatic setup
- Automatic magnetic pole detection function will detect the magnetic pole position of the linear motor.

General-purpose RS485 communication AE-LINK support type

## A5A series



Rated output:

**50 W to 15.0 kW**

- Positioning is possible by built-in NC function
- Can connect up to 31 axes
- Standard Ethernet cable<sup>\*2</sup> using

<sup>\*2</sup> AE-LINK is a registered trade mark of Asahi Engineering.

High-speed communication "Realtime Express" support model

Ultra high-speed Network type

## A5N series



Rated output:

**50 W to 15.0 kW**

- Synchronized motion and precise CP control up to 32 axes with 100 Mbps communication
- Standard Ethernet cable<sup>\*2</sup> using

Linear motor and DD motor control type

## A5NL series



Capacity of applying Linear motor:

**Compatible with 5.0 kW rotaly AC servo motor**

- Position, Speed and Thrust controls can be done by using the "Realtime Express"
- Drastically reduced setup time by automatic setup
- Automatic magnetic pole detection function will detect the magnetic pole position of the linear motor.

DC 24 V type

## A5MN series



Rated output:

**10 W, 20 W, 30 W**

- Synchronized motion and precise CP control up to 32 axes with 100 Mbps communication
- Standard Ethernet cable<sup>\*2</sup> using

Linear motor control, DC 24 V type

## A5MNL series

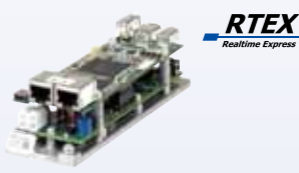

Capacity of applying Linear motor:

**Compatible with 30 W rotaly AC servo motor**

- Position, Speed and Thrust controls can be done by using the "Realtime Express"
- Drastically reduced setup time by automatic setup

[Special Order Product]: For details, see the website or request for information.

<sup>\*2</sup> Shielded twisted pair cable (CAT5e or higher)

Contents

### A5II, A5IIE, A5, A5E series

A5II Series Features.....	3
A5 Family Features.....	5
Motor Line-up.....	15
Model Designation.....	16
Overall Wiring .....	17
Driver and List of Applicable Peripheral Equipments .....	19
Table of Part Numbers and Options .....	21
Driver .....	29
<b>Driver Specifications</b>	
A5II, A5 series (All-in-one type) .....	29
A5IIE, A5E series (Position control type).....	31
<b>Wiring Diagram</b>	
Wiring to the Connector XA, XB, XC, XD and terminal block.....	33
<b>Safety Function</b>	
Wiring to the Connector X3.....	36
<b>Control Circuit Diagram</b>	
Wiring to the Connector X4.....	37
Wiring to the Connector X5.....	39
Wiring to the Connector X6.....	40
Dimensions of Driver .....	42
<b>Motor.....</b>	<b>48</b>
Motor Specifications .....	49
Dimensions (IP67 motor).....	137
Motors with Gear Reducer.....	141
<b>Special Order Product.....</b>	<b>151</b>
Model Designation .....	152
Table of Part Numbers and Options.....	153
Motor Specifications .....	155
Motor Specifications, Description .....	182
<b>Options.....</b>	<b>185</b>
Cable part No. Designation.....	185
Specifications of Motor connector.....	186
Encoder Cable .....	188
Motor Cable .....	191
Brake Cable .....	196
Interface Cable .....	197
Connector Kit.....	198
Battery for Absolute Encoder.....	207
Mounting Bracket.....	208
Reactor .....	209
External Regenerative Resister .....	210
Surge Absorber for Motor Brake .....	212
List of Peripheral Equipments.....	213
<b>E series.....</b>	<b>215</b>
<b>Information.....</b>	<b>246</b>
Index.....	288
Sales Office .....	305

# Quicker, Wiser and Friendlier A5II series

## Two-degree-of-freedom control system All-in-one type

• Full-closed control and torque control are not applicable to 2DOF control system.

## A5II series

Ball screw settling time  
**0 ms**

Belt device settling time  
**4 ms**

• The above is a measure based on our test environment.



## Two-degree-of-freedom control system Only for position control type

## A5IIE series



## Realizes quick and accurate movement. Fast response & High-precision positioning

### Adopted New Algorithm "Two-degree-of-freedom control" (2DOF) to improve productivity and machining accuracy.

In the conventional model, because we could not adjust separately feedforward control and feedback controls, in other words even if we only adjust "Approach" of feedforward, it had connection with "Settling" of

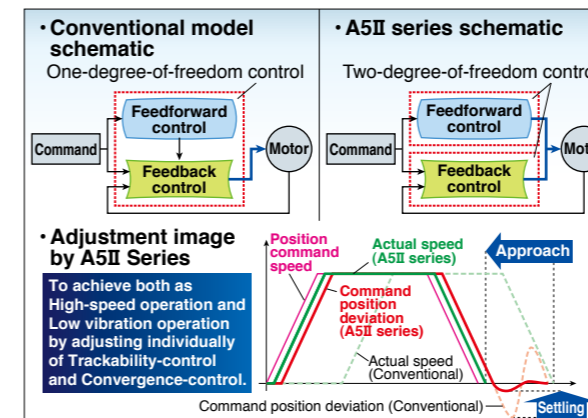

• Full-closed control and torque control are not applicable to 2DOF control system.

feedback control, mutual adjustment was required. In 2DOF adopted A5II series, feedforward and feedback controls are adjusted separately, meaning "Approach" reaction to the given command, and the "Settling" can be adjusted separately. Realized low vibration and reduction of settling time. Realizes tact speed of the electronic component mounting machines, improves the accuracy of surface treatment of metal processing machines, allows for smooth operation and High speed industrial robots.

### Waveform of PANATERM (the case of the ball screw: 0 ms / waveform measured settling time)

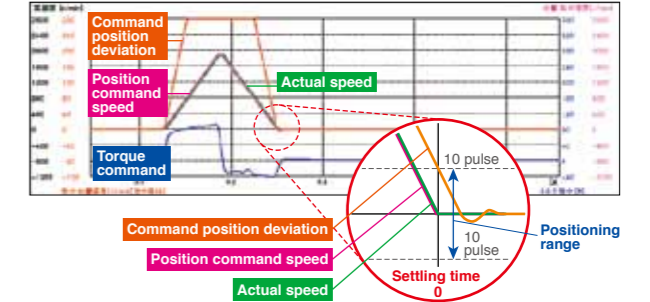

## Easy and quick adjusting time. 5 times faster\* than conventional

### Greatly improved "operability", easy-to-use software "PANATERM".

We have upgraded setup support software PANATERM, the convenient tool for parameter setting and monitoring often required during start-up of the machine for adjustment motor and driver. Improved to more easy-understandable screen.

### Equipped with "FitGain" function to realize speedy setup.

Newly developed feature "FitGain" maximizes the characteristics of A5II series. And adaptive notch filter function can reduce the vibration that occurs when the rigidity of the device is low, you can set and adjust automatically the best variety of gain.

### Adjustment is completed in only 3 processes



### Fit gain adjustment window

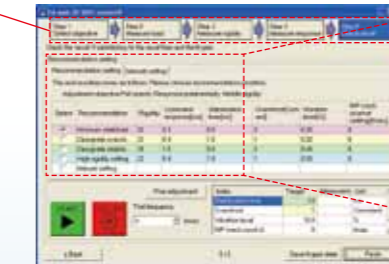

### Automatically proposes various settings

Selected	Recommendation	Rigidity	Command response[ms]	Stabilization resource[ms]
<input type="checkbox"/>	Minimum stabilizat.	22	3.2	0.0
<input type="checkbox"/>	Designate overal.	22	3.4	1.0
<input type="checkbox"/>	Designate steel.	19	1.5	3.5
<input type="checkbox"/>	Highly rigid setting	22	3.4	1.0
<input type="checkbox"/>	Master setting			

## Realized 2.3 kHz frequency response to improve productivity

### Comparison\* 1.15 times faster than conventional

Realized 2.3 kHz response makes possible high-speed operation and improves productivity.

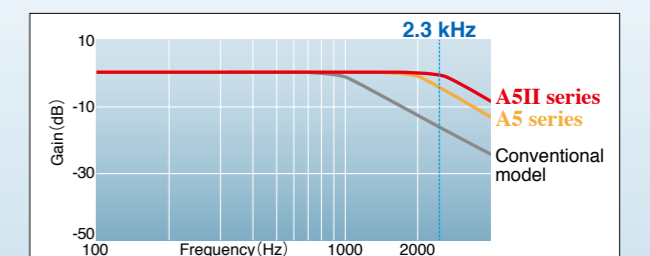

\* Comparison with conventional product A5-series.

1 Quick

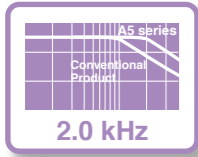

2.0 kHz Frequency Response A5 A5E

Example application Semiconductor production equipment, packaging, etc.

**Achieves the industry's leading frequency response of 2.0 kHz.**

Operation speed up by new developed LSI and high responsible control. **By the industry's leading speed and positioning response, a highly advanced system can be created. What's more, the shorter response delay will realize an extremely lower vibration.**

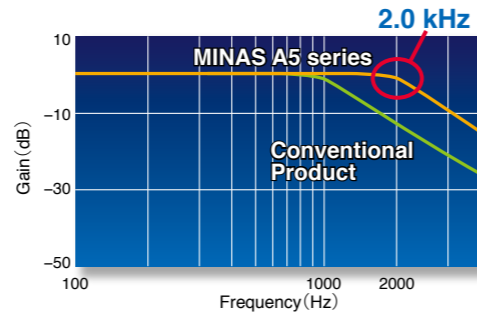

20 bits/revolution, 1.04 million pulses (At incremental type) A5II A5 A5IIE A5E

Example application Machine tools, textile machinery, etc.

**Ensures smoother operation and reduced vibration at stopping.**

**Ensures accurate positioning in a short time.**

New proprietary signal processing technology achieves 1.04 million pulses with a 20-bit incremental encoder.

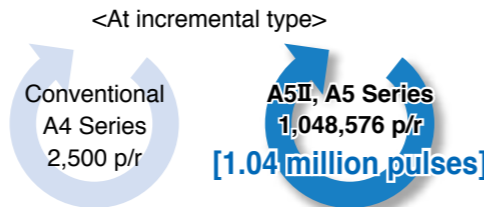

Low Cogging Torque (Excluding MSMD, MHMD, MDME 11.0 kW, 15.0 kW) A5II A5 A5IIE A5E

Example application Semiconductor production equipment, textile machinery, etc.

**For the industry's most stable speed and lowest cogging**

We've achieved the industry's lowest cogging by minimizing the pulse width by a new design incorporating a 10-pole rotor for the motor and a magnetic field parsing technique. **Positioning and stability are greatly improved by the minimal torque variation. This results to improved speed stability and positioning of motor rotation.**

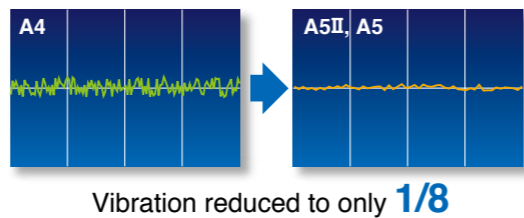

The Input/Output Pulse 4 Mpps A5II A5 A5IIE A5E

Example application Semiconductor production equipment, machine tools, etc.

**Accommodates the industry's leading positioning resolution commands (with pulse train commands).**

The command input and feedback output operate at the high speed of 4 Mpps. Accommodates high-resolution and high-speed operation, including standard full closed operation. (Provided with A5II, A5 only.)

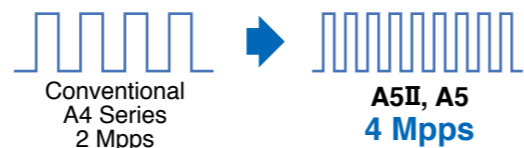

2 Smart



Highly Functional Real-time Auto-Gain Tuning A5II A5 A5IIE A5E

Example application Semiconductor production equipment, food processing machinery, etc.

**High-performance real-time auto-gain tuning featuring simple setup.**

After installation, tuning will be completed automatically after several operations. When the response is adjusted, **simple tuning** is supported with a change of one parameter value. Use of the gain adjustment mode in the setup support software contributes to optimum adjustment. **The built-in auto vibration suppression function reduces equipment damage.** Appropriate modes are provided for various machines such as **vertical axis machines and high friction machines with belts.**

This makes it possible to perform simple optimal adjustments simply by selecting the mode and stiffness.

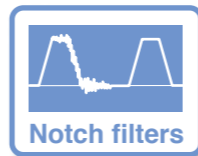
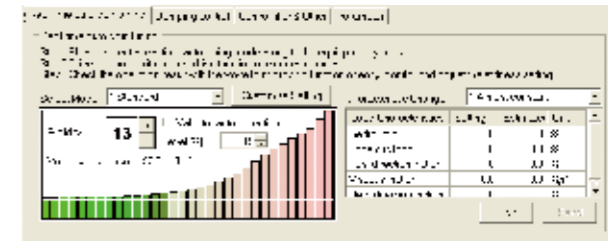

Manual/Auto Notch Filters A5II A5 A5IIE A5E

Example application Semiconductor production equipment, food processing machinery, etc.

**Equipped with auto-setting notch filters for greater convenience.**

Now there is no need to measure troublesome vibration frequencies. Our notch filters automatically detect vibration and provide simple auto-setting. These notch filters greatly reduce noise and vibration caused by equipment resonance and respond quickly

during operation. The A5II, A5 series features an industry-largest total of four notch filters with setup frequencies of 50 Hz to 5,000 Hz. This approach enables depth adjustment within this frequency range. (Two of the filters share the auto set-up.)

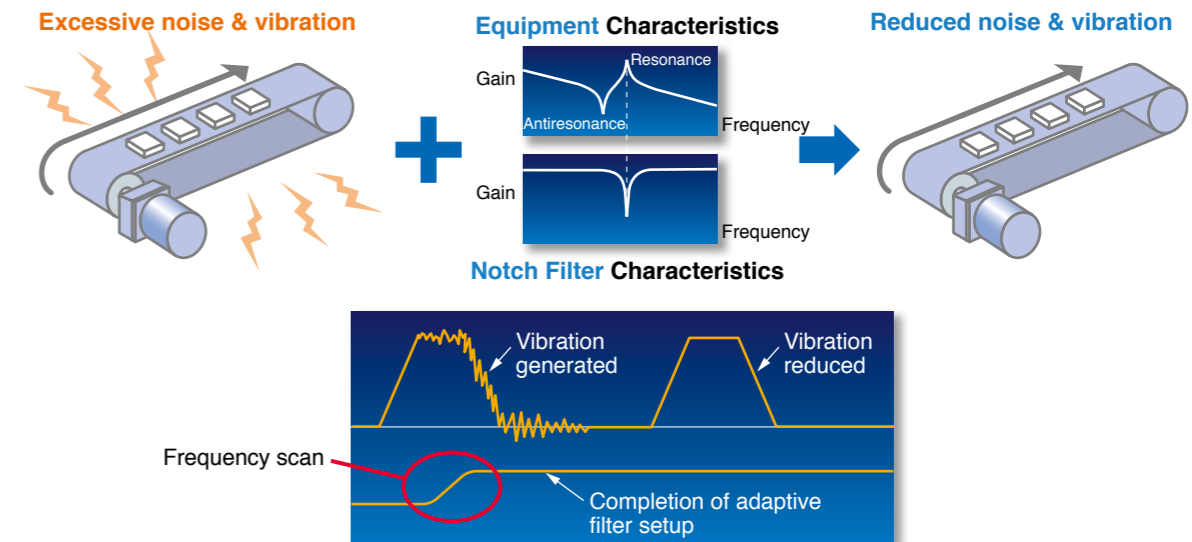



**Manual/Auto Damping Filter**

A5II A5 A5IIE A5E

**Example application** Chip mounters, food processing machinery, robots, general production machinery, etc.

**Equipped with a damping filter featuring simplified automatic setup.**

The setup software features automatic setup of the damping filter. **This filter removes the natural vibration frequency component from the command input, greatly reducing vibration of the axis when stopping.** The number of filters has been increased to four from the conventional two filters (two for simultaneous use). The adaptive frequency has also been significantly expanded from 1 Hz to 200 Hz.

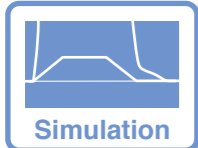
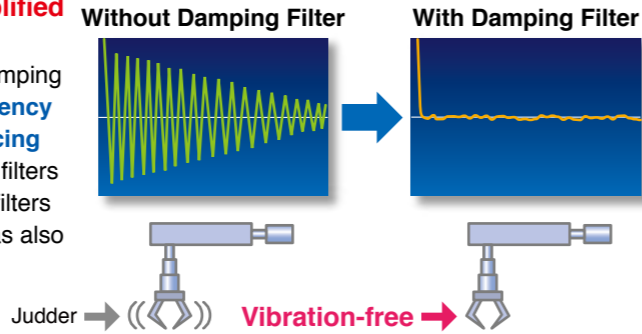

**Motion Simulation**

A5II A5 A5IIE A5E

**Example application** General production machinery, etc.

**Equipped with a simplified machine simulation function.**

The setup software uses frequency response data acquired from the actual machine. In addition, it features a machine simulation function for performing simulated operation. **This allows you to easily confirm the effects of gain and various filters without adjusting the actual equipment.**

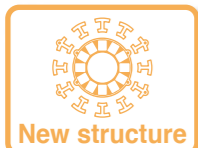
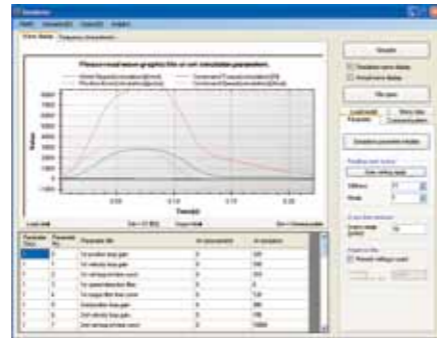

**New Structure/ Innovative Core/ Innovative Encoder**

(Excluding MSMD, MHMD type)

A5II A5 A5IIE A5E

**Example application** Robots, chip mounters, general production machinery, etc.



**Featuring significantly reduced weight and a more compact motor**

We've developed new designs for both compact motors and large motors. The new design used for the core has succeeded in compact. **The addition of an innovative compact encoder has contributed to a 10% to 25% (1 to 6 kg) reduction in motor weight in the 1 kW and larger class when compared with conventional motors.**



[Examples for MSM or MDM]

Series	A4	A5II A5	Weight Reduction
MSM 1 kW	4.5 kg	3.5 kg	▲1 kg
MSM 2 kW	6.5 kg	5.3 kg	▲1.2 kg
MDM 1 kW	6.8 kg	5.2 kg	▲1.6 kg
MDM 2 kW	10.6 kg	8.0 kg	▲2.6 kg



**Complies with European Safety Standards.**

A5II A5

**Example application** Semiconductor and LCD production equipment, etc.

**Compliance with EU safety standards.**

Features non-software-based independent redundant circuitry for motor power isolation. independent redundant circuitry for motor power isolation. This obviates the need for magnetic contactors to isolate

the required motor in order to accommodate low-voltage machinery commands. (The final safety compliance must be applied as machine.)



**Low noise**

A5II A5 A5IIE A5E

**Example application** Semiconductor and LCD production equipment, etc. general production machinery for export to the European market

**Complies with the European EMC Directive**

By incorporating the latest circuit technology, A5II, A5 series achieves a further noise reduction of 3 dB compared with the conventional A4 series, which also features noise suppression. (The A4 series also conforms to the EMC Directive.)

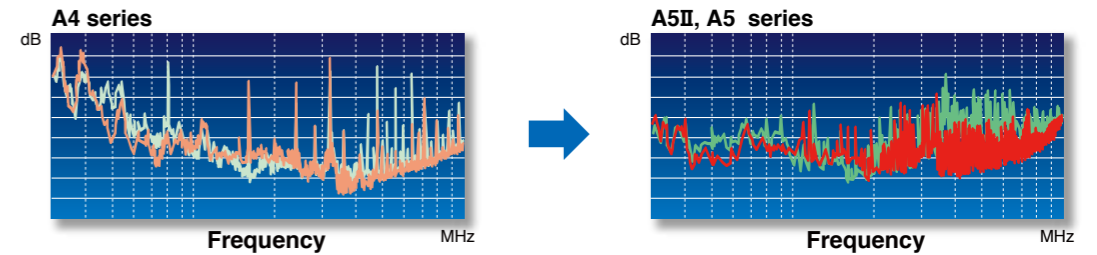

**IP67 Enclosure Rating** (Products are build to order items.)

A5II A5 A5IIE A5E

**Example application** Machine tools, robots, printing machines, etc.

**IP67 enclosure rating for increased environmental resistance**

Our improved motor seals and direct-mount connectors in the motor power supply and encoder input-output areas contribute to this unit's IP67 enclosure rating.

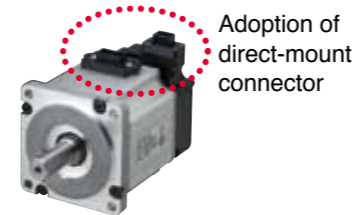

Adoption of direct-mount connector

- IP67**
- Protection against water
    - Protection against temporary immersion in water
  - Protection against dust
    - Protected against dust penetration when in full contact

- Motors of MSMD and MHMD series and 0.9 kW or higher standard stock items have IP65 rating.
- Motors of IP67 have smaller encoder connector that requires cable compatible with IP67 motor.
- \* IP67 motor is build to order items.

5 Easy

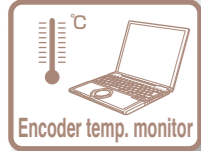

PANATERM Set-up Support Software

A5II A5 A5IIE A5E

The PANATERM Set-up Support Software, with many added features.

The PANATERM assists users in setting parameters, monitoring control conditions, setup support, and analyzing mechanical operation data on the PC screen, when installed in a commercially available personal computer, and connected to the MINAS A5 Family through the USB interface.

Localized in 4 languages

Choose either English, Japanese, Chinese, or Korean-language display.

Setup Wizard

This wizard supports fundamental settings in each control mode step by step, including reading of default setting. In on-line condition, input data related to each step can be monitored in real time.

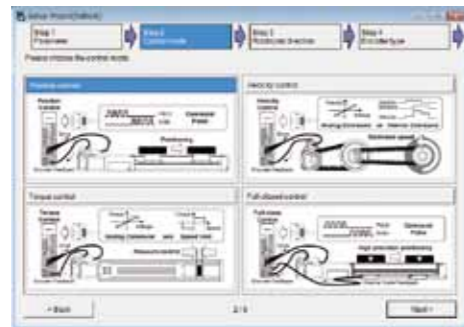

Fit gain

This function automatically searches the best suitable stiffness setting and mode and adjusts the gain once the target in-position range and setting time are set.

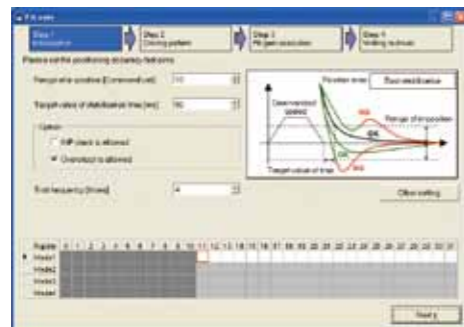

The fit gain function for setting two-degree-of-freedom control.

- 1) Select the adjustment method
- 2) Load measurement
- 3) Adjust gain to meet your needs by confirming results. (for A5II, A5IIE)



Service Life Prediction

The service life prediction function considers the internal temperature for main components such as the fan and condenser. If the rated value is exceeded, an alarm is displayed. This approach prevents unexpected suspension of operation and allows for planning of systemized maintenance.



Note: The life span prediction value should be considered as a guide only.

Encoder Temperature Monitor

The Encoder Temperature Monitor is a new function capable of real-time measurement of the interior temperature of the encoder, something that has been difficult to achieve in the past. It is valuable for monitoring the motor and can be used as a diagnostic in the event of a malfunction (provided with 20-bit encoder only).

Other New Function

The software offers a wide range of convenient features including motor and driver data such as load factor, voltage, and driver temperature. Moreover, the logging function records the interface history. As well, a non-rotating contributing factor display function.



Frequency characteristics measurement function

Can check frequency response characteristics of the mechanism and motor. Since resonance frequency of the mechanism is measurable, it is effective for start-up time reduction.

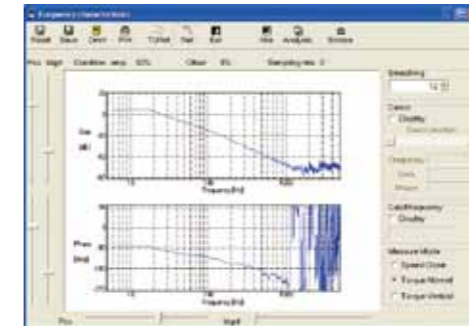

Added New screen for gain adjustment, equipped with stiffness oscillation auto-reduction function

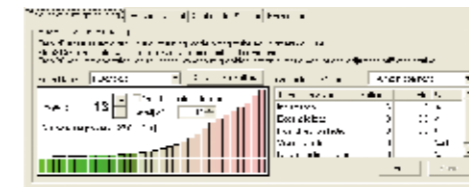

Trial run

This function supports positioning with the Z-phase search and software limit.



Significant increase of measuring objects Multi-functional waveform graphic

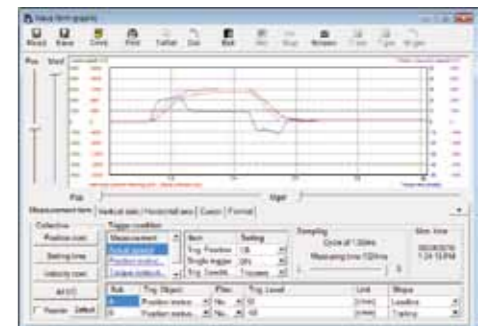

CAUTION

This software is applicable only to A5II, A5, A5IIE, A5E series. To apply this software to conventional product (A, AIII, E or A4 series), consult our distributors.

Hardware configuration

Personal computer	CPU	Pentium III 512MHz or more
	Memory	256MB or more (512MB recommended)
	Hard disk capacity	Vacancy of 512MB or more recommended
	OS	Windows® XP SP3 (32-bit Ver.), Windows® VISTA SP1 (32-bit Ver.) Windows® 7 (32-bit Ver., 64-bit Ver.) [English, Japanese, Chinese or Korean version]
Display	Serial communication port	USB port
	Resolution	1024 x 768pix or more (desirably 1024 x 768)
	Number of colors	24bit colors (TrueColor) or more

Please download from our web site and use after install to the PC.  
[http://industrial.panasonic.com/ww/i\\_e/25000/motor\\_fa\\_e/motor\\_fa\\_e.html](http://industrial.panasonic.com/ww/i_e/25000/motor_fa_e/motor_fa_e.html)

Other Functions

Command Control Mode A5II A5

- Command control mode is available for Position, Speed (including eight internal velocities) and Torque.
- Using parameter settings, you can set up one optional command control mode or two command control modes by switching.
- According to suitable application utility, proper optional command control mode can be chosen.

Full-closed Control A5II A5

AB-phase linear scale (for general all-purpose products) or serial scale (for products with Panasonic's exclusive format) scales can be used (P.14).

SEMI F47 A5II A5 A5IIE A5E

- Includes a function in compliance with the SEMI F47 standard for voltage sag immunity under no load or light load.
  - Ideal for the semiconductor and LCD industries.
- Notes:
- 1) Excluding the single-phase 100-V type.
  - 2) Please verify the actual compliance with your machine checking the F47 standard for voltage sag immunity.

Inrush Current Preventive Function A5II A5 A5IIE A5E

- This driver is equipped with a rush current preventive resistor to prevent the circuit breaker from shutting off the power supply as a result of inrush current occurring at power-on.

Regenerative Energy Discharge A5II A5 A5IIE A5E

- A regenerative resistor is used to discharge regenerative energy, which is the energy generated when stopping a load with a large moment of inertia or when using this unit in vertical operation. This energy is returned to the driver from the motor.
- Frame A, B, G and frame H model drivers do not contain a regenerative resistor. Optional regenerative resistors are recommended.
- Frame C to frame F model drivers contain one regenerative resistor; however, adding an optional regenerative resistor provides additional regeneration capability.

6,000-rpm capability A5II A5 A5IIE A5E  
(build to order item)

The MSME motor (under 750 W) can accommodate a maximum speed of 6,000 r/min.

[Comparison of new and conventional 200 W]

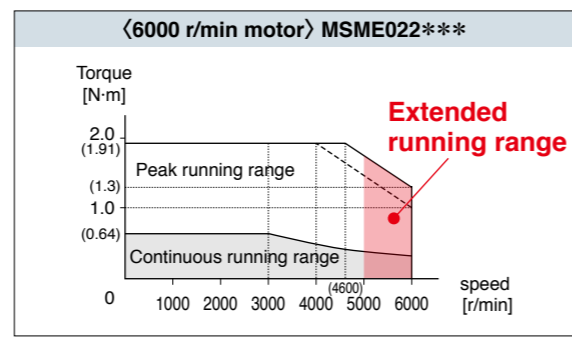
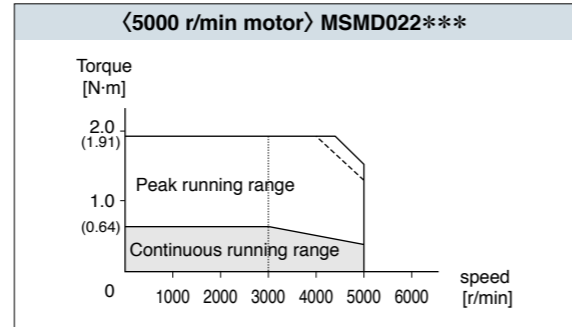

- **Gear head**  
Gear heads for 6000 r/min and 5000 r/min motors are available. Set 5000 r/min gear head only to 5000 r/min motor, and set 6000 r/min gear head only to 6000 r/min motor.  
When customers prepare a gear head, use it as follows:  
MSME → 6000 r/min  
MSMD } → 5000 r/min  
MHMD }

Dynamic Braking A5II A5 A5IIE A5E

- With parameter settings, you can select dynamic braking, which shorts servomotor windings U, V and W at Servo-OFF, during positive direction/ negative direction, and during power shutdown and tripping of the circuit breaker for over travel inhibition.  
\* The dynamic brake circuit of H-frame is external.
- The desired action sequence can be set up to accommodate your machine requirements.

Parameter Initialization A5II A5 A5IIE A5E

Using the front panel or by connecting a PC, you can restore the parameters to the factory settings.

Disturbance Observer A5II A5 A5IIE A5E

By using a disturbance observer to add an estimated disturbance torque value to the torque canceling command, this function diminishes the impact of the disturbance torque, reduces vibration, and offsets any speed decline.

Disturbance observer function not in effect

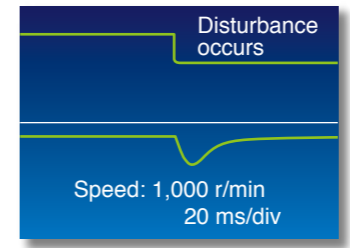

Disturbance observer function in effect

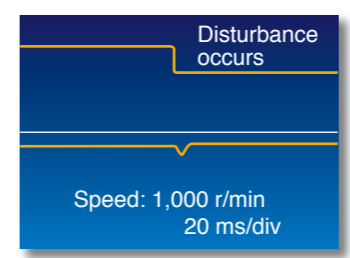

Torque Feed Forward A5II A5 A5IIE A5E

The Torque Feed Forward function performs a comparison with feedback and calculates the amount of torque to add to the necessary torque command in the command for actuation.

Friction Torque Compensation A5II A5 A5IIE A5E

This function reduces the effect of machine-related friction and improves responsiveness. Two kinds of friction compensation can be set up: unbalanced load compensation, which compensates with a constant operational offset torque; and kinetic friction, which changes direction in response to the direction of movement.

3-Step Gain A5II A5 A5IIE A5E

A 3-step gain switch is available in addition to the normal gain switch. This chooses appropriate gain tunings at both stopping and running. The 3-step gain switch gives you choices of 3 different tunings for normal running, stopping for faster positioning and at stopping. The right gaining tunings achieve lower vibration and quicker positioning time of your application.

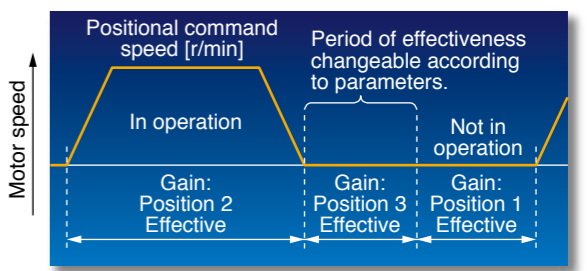

Inertia Ratio Conversion A5II A5 A5IIE A5E

You can adjust right inertia ratio by Inertia Ratio Conversion input(J-SEL). When you have significant load inertia changes, it can adjust unbalanced speed and position gain turning combination. It ends up quicker response of your system.

Input/Output Signal Assignment A5II A5 A5IIE A5E

You can use the parameters to arbitrarily allocate the universal 10 inputs and 6 outputs. (Inputs can be selected as either A contacts or B contacts). The Panatorm setup software provides an exclusive screen for a more simplified setup.

Torque Limiter Switching A5II A5 A5IIE A5E

You can use the I/Os to set up torque limits. These can be used for applications such as simplified pressure, tension control, and sensor-less homing.

Applicable international safety standards

A5II A5 A5IE A5E



		Driver	Motor
EC Directives	EMC Directives	EN55011 EN61000-6-2 IEC61800-3	—
	Low-Voltage Directives	EN61800-5-1	EN60034-1 EN60034-5
	Machinery Directives Functional safety <sup>*1</sup>	ISO13849-1(PL d) (Cat. 3) EN61508(SIL2) EN62061(SILCL 2) EN61800-5-2(STO) IEC61326-3-1	—
UL Standards	UL508C (E164620)	UL1004-1 ( E327868: 50 W to 750 W, ) 6.0 kW to 15.0 kW ) UL1004 ( E327868: 400 W(400 V), 600 W(400 V), ) 750 W(400 V), 0.9 kW to 5.0 kW )	
CSA Standards	C22.2 No.14	C22.2 No.100	
Korea Radio Law (KC) <sup>*2</sup>	KN11 KN61000-4-2, 3, 4, 5, 6, 8, 11	—	

IEC : International Electrotechnical Commission  
 EN : Europaischen Normen  
 EMC : Electromagnetic Compatibility  
 UL : Underwriters Laboratories  
 CSA : Canadian Standards Association

Pursuant to the directive 2004/108/EC, article 9(2)  
 Panasonic Testing Centre  
 Panasonic Service Europe, a division of  
 Panasonic Marketing Europe GmbH  
 Winsbergring 15, 22525 Hamburg, F.R. Germany

• When export this product, follow statutory provisions of the destination country.

\*1 A5IE and A5E series doesn't correspond to the functional safety standard.

\*2 Information related to the Korea Radio Law

This servo driver is a Class A commercial broadcasting radio wave generator not designed for home use.  
 The user and dealer should be aware of this fact.

A 급 기기 (업무용 방송통신기자재)

이 기기는 업무용(A 급) 전자파적합기기로서 판매자 또는 사용자는 이 점을 주의하시기 바라며, 가정외의 지역에서 사용하는 것을 목적으로 합니다.

( 대상기종 : Servo Driver )

This product is not an object of China Compulsory Certification (CCC).

Applicable External Scales

A5II A5

Applicable External Scale	Manufacturer	Model No.	Resolution [μs]	Maximum Speed (m/s) <sup>3</sup>
Parallel Type (AB-phase)	General	—	Maximum speed after 4 × multiplication: 4 Mpps	
Serial Type (Incremental)	Magnescale Co., Ltd.	SR75	0.01 to 1	3.3
		SR85	0.01 to 1	3.3
		SL700-PL101RP/RHP	0.1	10
	SL710-PL101RP/RHP	0.1	10	
	MicroE Systems	MI5000si/P MI6000si/P	0.1 <sup>*4</sup>	5 <sup>*5</sup>
Serial Type (Absolute)	Mitutoyo Corporation	AT573A	0.05	2.5
		ST778A(L)	0.1	5
	Magnescale Co., Ltd.	SR77	0.01 to 1	3.3
		SR87	0.01 to 1	3.3
	Renishaw plc	RESOLUTE	0.001	0.4
			0.05	20
			0.1	40
	Fagor Automation S.Coop	SVAP	0.05	2.5
SAP		0.05	2.5	
GAP		0.05	2.5	
LAP		0.1	2	

\*3 The maximum speed is a characteristic of the driver. It is limited by the configuration of the machine and the system.

\*4 It changes by the setting.

\*5 At 0.1 μm resolution.



Motor Line-up

Motor	Voltage	Rated output (kW)	Rated rotational speed (Max. speed) (r/min)	Rotary encoder		Enclosure (*1)	Features	Applications
				20-bit incremental	17-bit absolute			
Low inertia	MSMD	100 V	0.05 0.1	3000 (5000)		IP65	• Leadwire type • Small capacity • Suitable for high speed application • Suitable for all applications	• Bonder • Semiconductor production equipment • Packing machines etc
		200 V	0.2 0.4					
	MSME	200 V	0.75	3000 (6000)		IP67	• Small capacity • Suitable for high speed application • Suitable for all applications	• SMT machines • Food machines • LCD production equipment etc
		100 V	0.05 0.1					
		200 V	0.2 0.4					
		400 V	0.75					
Middle inertia	MDME	400 V	0.4 0.6	2000 (3000)		IP65(*2)	• Middle capacity • Suitable for low stiffness machines with belt driven	• Conveyors • Robots • Machine tool etc
		200 V	1.0 1.5					
			2.0 3.0					
		400 V	4.0 5.0					
			7.5 (*3)					
	MFME (Flat type) (*3)	200 V	1.5	2000 (3000)		IP67	• Middle capacity • Flat type and suitable for machines with space limitation	• Robots • Food machines etc
			2.5					
		4.5						
		400 V	0.9 2.0					
			3.0					
MGME (Low speed/High torque type) (*3)	200 V	4.5 (*3)	1000 (2000)		IP65(*2)	• Middle capacity • Suitable for low speed and high torque application	• Conveyors • Robots • Textile machines etc	
		6.0 (*3)						
	400 V	0.2						
High inertia	MHMD	100 V	0.2	3000 (5000)		IP65	• Leadwire type • Small capacity • Suitable for low stiffness machines with belt driven	• Conveyors • Robots etc
		200 V	0.4					
	MHME	200 V	0.75	3000 (4500)		IP65(*2)	• Middle capacity • Suitable for low stiffness machines with belt driven, and large load moment of inertia	• Conveyors • Robots • LCD manufacturing equipment etc
		400 V	1.0 1.5					
		2.0 3.0	2000 (3000)		IP65(*2)			
		4.0 5.0						
		7.5 (*3)	1500 (3000)		IP65(*2)			
		0.75						

(\*1) Except for output shaft, and connector. (\*2) IP67 motor is also available. (\*3) Only IP67 motor is available.

\* See the P.21 to P.28, driver and motor combination.

\* For combination of elements of model number, refer to Index.

Servo Motor

**M S M E 5 A Z G 1 S \* \***

Symbol	Type
MSMD	Low inertia (50 W to 750 W)
MSME	Low inertia (50 W to 5.0 kW)
MDME	Middle inertia (400 W to 15.0 kW)
MFME	Middle inertia (1.5 kW to 4.5 kW)
MGME	Middle inertia (0.9 kW to 6.0 kW)
MHMD	High inertia (200 W to 750 W)
MHME	High inertia (1.0 kW to 7.5 kW)

**Special specifications**  
**Motor specifications**  
**MSME(50 W to 750 W [200 V]), MSMD, MHMD**

Symbol	Shaft		Holding brake		Oil seal		
	Round	D-cut	Key-way, center tap	without	with	without	with
A	●			●		●	
B	●			●	●	●	
C	●			●		●	●
D	●			●	●	●	●
N		●		●		●	
P		●		●	●	●	
Q		●		●		●	●
R		●		●	●	●	●
S			●	●		●	●
T			●	●	●	●	●
U			●	●		●	●
V			●	●		●	●

**Motor rated output**

Symbol	Rated output	Symbol	Rated output
5A	50 W	25	2.5 kW
01	100 W	30	3.0 kW
02	200 W	40	4.0 kW
04	400 W	45	4.5 kW
06	600 W	50	5.0 kW
08	750 W	60	6.0 kW
09	0.9 kW	75	7.5 kW
10	1.0 kW	C1	11.0 kW
15	1.5 kW	C5	15.0 kW
20	2.0 kW		

**Voltage specifications**

Symbol	Specifications
1	100 V
2	200 V
4	400 V
Z	100 V/200 V common (50 W only)

**Rotary encoder specifications**

Symbol	Format	Pulse counts	Resolution	Wires
G	Incremental	20-bit	1,048,576	5
S	Absolute	17-bit	131,072	7

**Design order**

Symbol	Specifications
C	IP65 motor
1	IP67 motor (MSMD, MHMD: IP65)

\* S: can be used in incremental.

Motor with reduction gear

**M S M E 0 1 1 G 3 1 N**

Symbol	Type
MSMD	Low inertia (100 W to 750 W)
MSME	Low inertia (100 W to 750 W)
MHMD	High inertia (200 W to 750 W)

**Motor rated output**

Symbol	Rated output
01	100 W
02	200 W
04	400 W
08	750 W

**Voltage specifications**

Symbol	Specifications
1	100 V
2	200 V

**Rotary encoder specifications**

Symbol	Format	Pulse counts	Resolution	Wires
G	Incremental	20-bit	1,048,576	5
S	Absolute	17-bit	131,072	7

**Gear ratio, gear type**

Symbol	Gear reduction ratio	Motor output (W)				Gear type
		100	200	400	750	
1N	1/5	●	●	●	●	For high accuracy
2N	1/9	●	●	●	●	
3N	1/15	●	●	●	●	
4N	1/25	●	●	●	●	

\* MHMD 100W is not prepared.

**Motor structure**

Symbol	Shaft		Holding brake	
	Key-way	without	without	with
3	●		●	
4	●		●	

\* S: can be used in incremental.

Servo Driver

**Speed, Position, Torque, Full-closed type** **M A D K T 1 5 0 5 \* \* \*** — Special specifications

**Position control type** **M A D K T 1 5 0 5 E \* \*** — Special specifications

**Frame symbol \***

Symbol	Frame	Symbol	Frame
MAD	Frame A	MED	Frame E
MBD	Frame B	MFD	Frame F
MCD	Frame C	MGD	Frame G
MDD	Frame D	MHD	Frame H

\* A5IE, A5E series is up to F-frame.

**Power device Max. current rating**

Symbol	Current rating
T1	10 A
T2	15 A
T3	30 A
T4	35 A
T5	50 A
T7	75 A
TA	100 A
TB	150 A
TC	300 A

**Current detector current rating**

Symbol	Specifications	Symbol	Specifications
05	5 A	40	40 A
07	7.5 A	64	64 A
10	10 A	90	90 A
12	12 A	A2	120 A
20	20 A	B4	240 A
30	30 A		

**Supply voltage specifications**

Symbol	Specifications
1	Single phase, 100 V
3	3-phase, 200 V
4	3-phase, 400 V
5	Single/3-phase, 200 V

**Series**

Symbol	Velocity, Position, Torque, Full-Closed type	Position control type
K	A5I series	A5IE series
H	A5 series	A5E series

[Connector type (100/200 V: A to E-frame)]

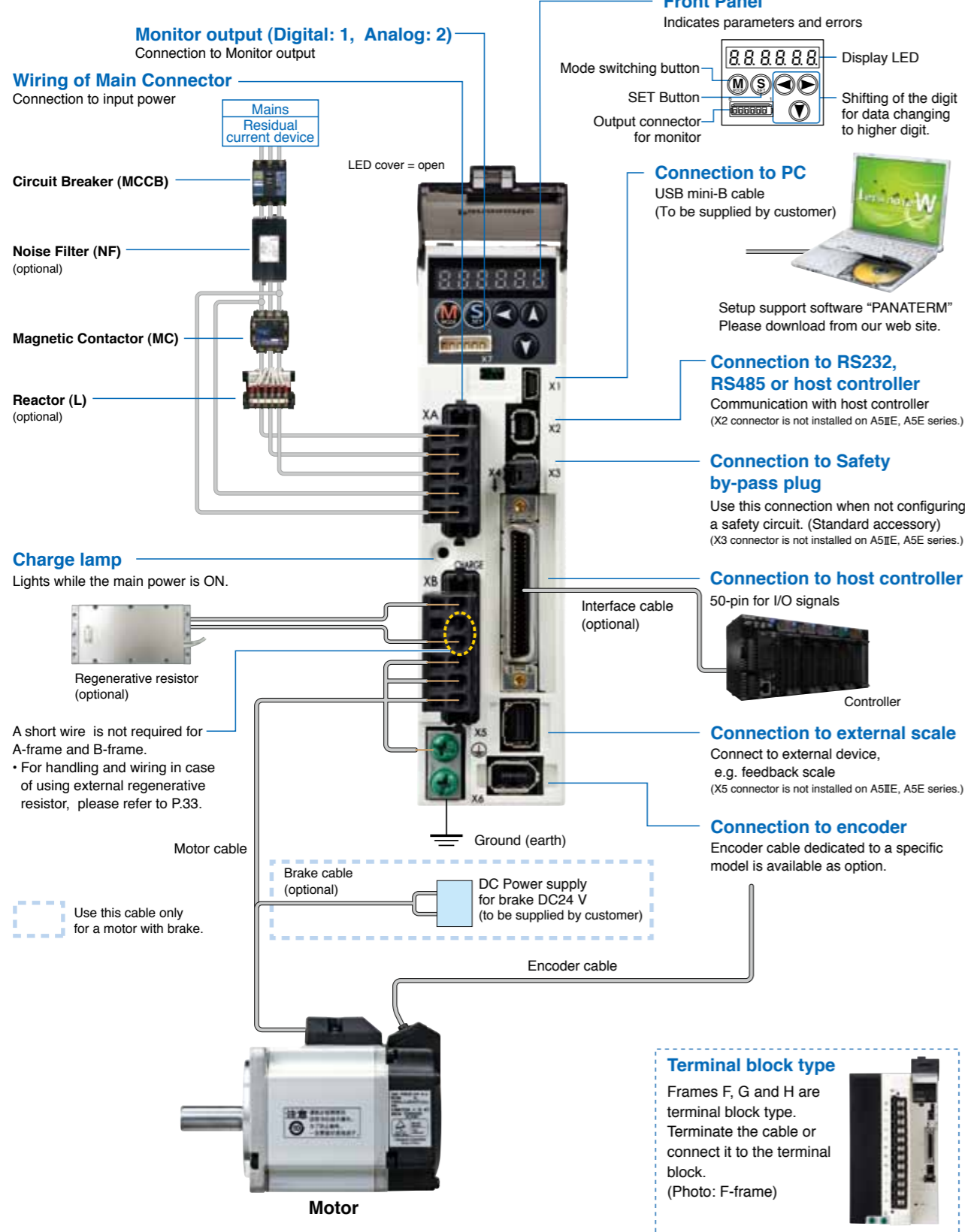

<Caution>

Apply adequate tightening torque to the product mounting screw by taking into consideration strength of the screw and the characteristics of material to which the product is installed. Overtightening can damage the screw and/or material; undertightening can result in loosening.  
Example) Steel screw (M5) into steel section: 2.7 N·m to 3.3 N·m.

[Connector type (400 V: D, E-frame)]

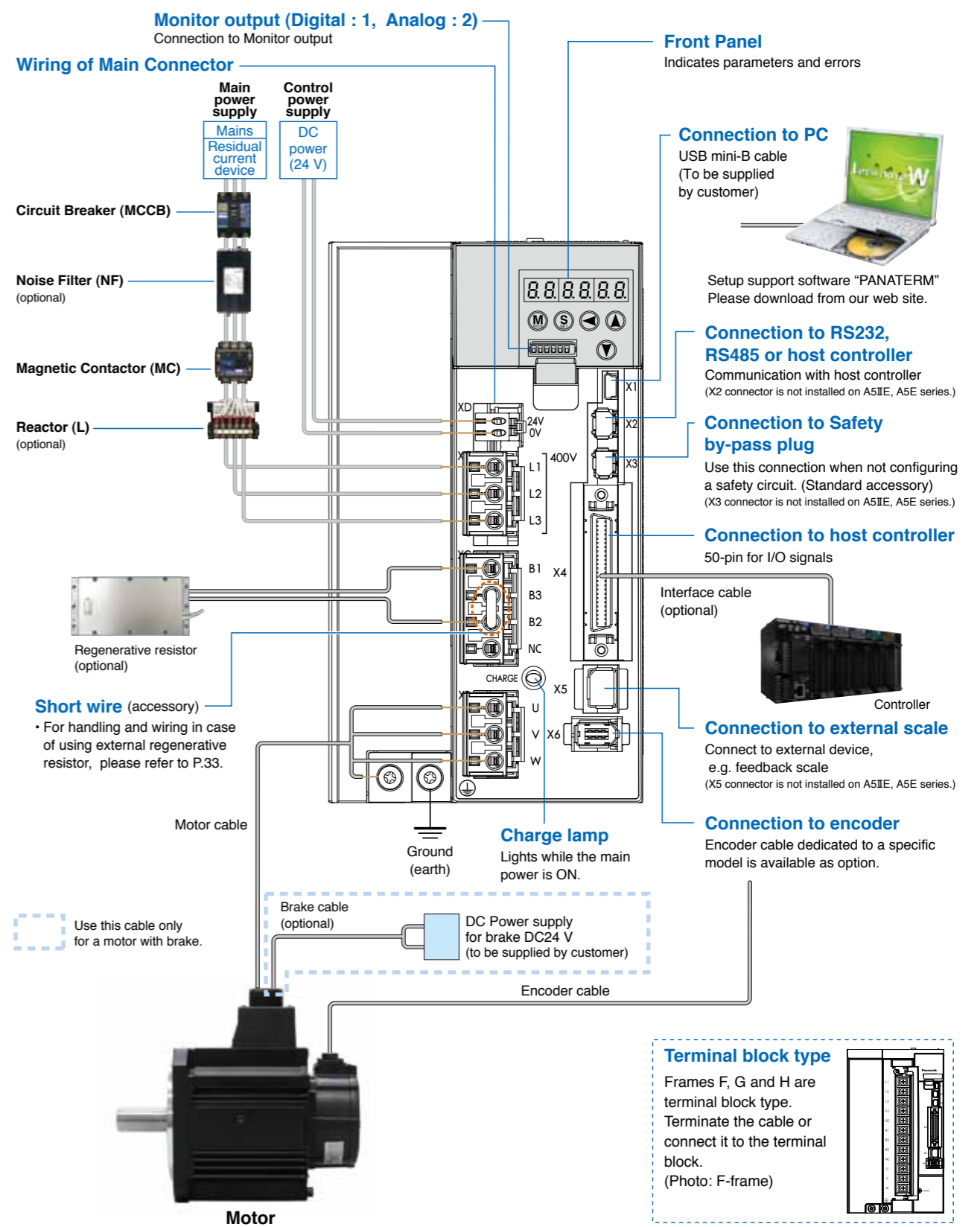

<Note>

Initial setup of rotational direction: positive = CCW and negative = CW.  
Pay an extra attention.

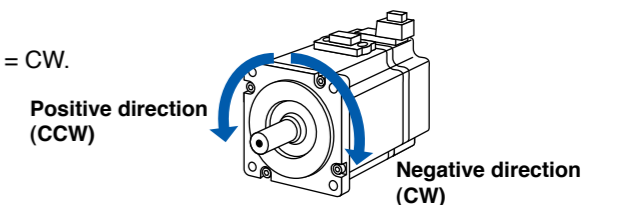

# Driver and List of Applicable Peripheral Equipments

Driver	Applicable motor	Voltage	Rated output	Required Power (at the rated load)	Circuit breaker (rated current)	Noise filter (Single phase/3-phase)	Surge absorber (Single phase/3-phase)	Noise filter for signal	Rated operating current of magnetic contactor (configuration *1)	Diameter and withstand voltage of main circuit cable	Crimp terminal for main circuit terminal block *3	Diameter and withstand voltage of control power supply cable	Crimp terminal for control power supply terminal block	Diameter and withstand voltage of motor cable *4	Diameter and withstand voltage of brake cable
MADH MADK	MSME MSMD MHMD	Single phase, 100 V	50 W to 100 W	approx. 0.4 kVA	10 A	DV0P4170	DV0P4190		20 A (3P+1a)	0.75 mm <sup>2</sup> / AWG18 600 VAC or more		0.75 mm <sup>2</sup> / AWG18 600 VAC or more	0.75 mm <sup>2</sup> / AWG18 600 VAC or more	0.28 mm <sup>2</sup> to 0.75 mm <sup>2</sup> / AWG22 to AWG18 100 VAC or more	
		Single/3-phase, 200 V	50 W to 200 W	approx. 0.5 kVA		DV0P4170 DV0PM20042	DV0P4190 DV0P1450								
MBDH MBDK	MSME MSMD MHMD	Single 100 V	200 W	approx. 0.5 kVA	10 A	DV0P4170	DV0P4190		20 A (3P+1a)	0.75 mm <sup>2</sup> / AWG18 600 VAC or more		0.75 mm <sup>2</sup> / AWG18 600 VAC or more	0.75 mm <sup>2</sup> / AWG18 600 VAC or more	0.28 mm <sup>2</sup> to 0.75 mm <sup>2</sup> / AWG22 to AWG18 100 VAC or more	
		Single/3-phase, 200 V	400 W	approx. 0.9 kVA		DV0P4170 DV0PM20042	DV0P4190 DV0P1450								
MCDH MCDK	MSME MSMD MHMD	Single 100 V	400 W	approx. 0.9 kVA	15 A	DV0PM20042	DV0P4190		20 A (3P+1a)	0.75 mm <sup>2</sup> / AWG18 600 VAC or more		0.75 mm <sup>2</sup> / AWG18 600 VAC or more	0.75 mm <sup>2</sup> / AWG18 600 VAC or more	0.28 mm <sup>2</sup> to 0.75 mm <sup>2</sup> / AWG22 to AWG18 100 VAC or more	
		Single/3-phase, 200 V	750 W	approx. 1.3 kVA		DV0PM20042	DV0P4190								
MDDH MDDK	MDME MHME MGME	Single/3-phase, 200 V	1.0 kW	approx. 1.8 kVA	20 A	DV0P4220	DV0P1450	DV0P1460	30 A (3P+1a)	2.0 mm <sup>2</sup> / AWG14 600V VAC or more	Connection to exclusive connector	Connection to exclusive connector	2.0 mm <sup>2</sup> / AWG14 600V VAC or more	0.28 mm <sup>2</sup> to 0.75 mm <sup>2</sup> / AWG22 to AWG18 100 VAC or more	
			0.9 kW	approx. 1.8 kVA											
			1.0 kW	approx. 1.8 kVA											
		MSME MHME MDME MFME MSME	Single/3-phase, 200 V	1.5 kW	approx. 2.3 kVA	20 A	DV0P4220	DV0P1450	DV0P1460	30 A (3P+1a)	2.0 mm <sup>2</sup> / AWG14 600V VAC or more	Connection to exclusive connector	Connection to exclusive connector	2.0 mm <sup>2</sup> / AWG14 600V VAC or more	0.28 mm <sup>2</sup> to 0.75 mm <sup>2</sup> / AWG22 to AWG18 100 VAC or more
		MDME		400 W	approx. 0.9 kVA										
		MDME		600 W	approx. 1.2 kVA										
		MSME		750 W	approx. 1.6 kVA										
		MSME MDME MHME MGME MSME MDME MFME MHME	3-phase, 400 V	1.0 kW	approx. 1.8 kVA	10 A	FN258L-16-07 (Recommended component)	DV0PM20050	DV0P1460	20 A (3P+1a)	2.0 mm <sup>2</sup> / AWG14 600V VAC or more	Connection to exclusive connector	Connection to exclusive connector	2.0 mm <sup>2</sup> / AWG14 600V VAC or more	0.28 mm <sup>2</sup> to 0.75 mm <sup>2</sup> / AWG22 to AWG18 100 VAC or more
		0.9 kW		approx. 1.8 kVA											
		1.5 kW		approx. 2.3 kVA											
	MDME MSME MHME	3-phase, 200 V	2.0 kW	approx. 3.3 kVA	30 A	DV0PM20043	DV0P1450	DV0P1460 RJ8035 (Recommended component) *5	60 A (3P+1a)	0.75 mm <sup>2</sup> / AWG18 600 VAC or more	Connection to exclusive connector	Connection to exclusive connector	0.75 mm <sup>2</sup> / AWG18 600 VAC or more	0.28 mm <sup>2</sup> to 0.75 mm <sup>2</sup> / AWG22 to AWG18 100 VAC or more	
	MFME		2.5 kW	approx. 3.8 kVA											
	MSME MDME MHME MFME	3-phase, 400 V	2.0 kW	approx. 3.3 kVA	15 A	FN258L-16-07 (Recommended component)	DV0PM20050	DV0P1460	30 A (3P+1a)	0.52 mm <sup>2</sup> / AWG20 100 VAC or more	Connection to exclusive connector	Connection to exclusive connector	0.52 mm <sup>2</sup> / AWG20 100 VAC or more	0.28 mm <sup>2</sup> to 0.75 mm <sup>2</sup> / AWG22 to AWG18 100 VAC or more	
	MFME		2.5 kW	approx. 3.8 kVA											
	MGME MDME MHME MSME MGME MDME MHME MFME MGME MDME MHME MSME	3-phase, 200 V	2.0 kW	approx. 3.3 kVA	50 A	DV0P3410	DV0P1450	DV0P1460 RJ8035 (Recommended component) *5	60 A (3P+1a)	0.75 mm <sup>2</sup> / AWG18 600 VAC or more	Terminal block M5	Terminal block M5	0.75 mm <sup>2</sup> / AWG18 600 VAC or more	0.28 mm <sup>2</sup> to 0.75 mm <sup>2</sup> / AWG22 to AWG18 100 VAC or more	
	3.0 kW		approx. 4.5 kVA												
	4.0 kW		approx. 6.0 kVA												
	4.5 kW		approx. 6.8 kVA												
	5.0 kW		approx. 7.5 kVA												
	5.0 kW		approx. 7.5 kVA												
	MGME MSME MDME MHME MGME MSME MDME MHME	3-phase, 400 V	2.0 kW	approx. 3.8 kVA	30 A	FN258L-30-07 (Recommended component)	DV0PM20050	DV0P1460	60 A (3P+1a)	0.75 mm <sup>2</sup> / AWG18 100 VAC or more	Terminal block M4	Terminal block M3	0.75 mm <sup>2</sup> / AWG18 100 VAC or more	0.28 mm <sup>2</sup> to 0.75 mm <sup>2</sup> / AWG22 to AWG18 100 VAC or more	
	3.0 kW		approx. 4.5 kVA												
	4.0 kW		approx. 6.0 kVA												
	4.5 kW		approx. 6.8 kVA												
	5.0 kW		approx. 7.5 kVA												
	5.0 kW		approx. 7.5 kVA												
	MDME MGME MHME	3-phase, 200 V	7.5 kW	approx. 11 kVA	60 A	FS5559-60-34 (Recommended component)	DV0P1450	DV0P1460 RJ8095 (Recommended component) *5	100 A (3P+1a)	0.75 mm <sup>2</sup> / AWG18 600 VAC or more	Terminal block M5	Terminal block M5	0.75 mm <sup>2</sup> / AWG18 600 VAC or more	13.3 mm <sup>2</sup> / AWG6 600 VAC or more	
	MGME		6.0 kW	approx. 9.0 kVA											
	MHME		7.5 kW	approx. 11 kVA											
	MDME MGME MHME	3-phase, 400 V	7.5 kW	approx. 11 kVA	30 A	FN258-42-07 or FN258-42-33 (Recommended component)	DV0PM20050	DV0P1460 RJ8095 (Recommended component) *5	60 A (3P+1a)	0.75 mm <sup>2</sup> / AWG18 100 VAC or more	Terminal block M5	Terminal block M5	0.75 mm <sup>2</sup> / AWG18 100 VAC or more	13.3 mm <sup>2</sup> / AWG6 600 VAC or more	
	MGME		6.0 kW	approx. 9.0 kVA											
	MHME		7.5 kW	approx. 11 kVA											
	MDME	3-phase, 200 V	11 kW	approx. 17 kVA	100 A	FS5559-80-34 (Recommended component)	DV0P1450	T400-61D (Recommended component) *5	150 A (3P+1a)	0.75 mm <sup>2</sup> / AWG18 600 VAC or more	Terminal block M6	Terminal block M4	21.1 mm <sup>2</sup> / AWG4 600 VAC or more	13.3 mm <sup>2</sup> / AWG6 600 VAC or more	
	MHME		15 kW	approx. 22 kVA											
	MDME	3-phase, 400 V	11 kW	approx. 17 kVA	50 A	FN258-42-07 or FN258-42-33 (Recommended component)	DV0PM20050		100 A (3P+1a)	0.75 mm <sup>2</sup> / AWG18 100 VAC or more	Terminal block M4	Terminal block M4	21.1 mm <sup>2</sup> / AWG4 600 VAC or more	13.3 mm <sup>2</sup> / AWG6 600 VAC or more	
	MHME		15 kW	approx. 22 kVA											

- \*1 For the external dynamic brake resistor, use the magnetic contactor with the same rating as that for the main circuit.
- \*2 When use the external regenerative resistor of the option (DV0PM20058, DV0PM20059), use the cable with the same diameter as the main circuit cable.
- \*3 For the ground screw, use the same crimp terminal as that for the main circuit terminal block.
- \*4 The diameter of the ground cable and the external dynamic brake resistor cable must be equal to, or larger than that of the motor cable.  
The motor cable is a shield cable, which conforms to the EC Directives and UL Standards. (G, H-frame only)
- \*5 Use these products to suit an international standard.

• Related page

- Noise filter .....P.250 “Composition of Peripheral Equipments”
- Surge absorber.....P.253 “Composition of Peripheral Equipments”
- Noise filter for signal.....P.254 “Composition of Peripheral Equipments”
- Motor/brake connector .....P.186, P.187 “Specifications of Motor connector”

• About circuit breaker and magnetic contactor

To comply to EC Directives, install a circuit breaker between the power and the noise filter without fail, and the circuit breaker should conform to IEC Standards and UL recognized (Listed and  marked). Suitable for use on a circuit capable of delivering not more than 5,000 Arms symmetrical amperes, below the maximum input voltage of the product.

If the short-circuit current of the power supply exceeds this value, install a current limit device (current limiting fuse, current limiting circuit breaker, transformer, etc.) to limit the short-circuit current.

<Remarks>

- Select a circuit breaker and noise filter which match to the capacity of power supply (including a load condition).
- Terminal block and protective earth terminals
  - Use a copper conductor cables with temperature rating of 75 °C or higher.
  - Use the attached exclusive connector for A to E-frame, and maintain the peeled off length of 8 mm to 9 mm.

Fastening torque list (Terminal block screw/Terminal cover fastening screw)

Frame	Driver	Terminal block screw		Terminal cover fastening screw	
		Nominal size	Fastening torque (N•m)	Nominal size	Fastening torque (N•m)
F(200 V)	L1, L2, L3, L1C, L2C, B1, B2, B3, NC, U, V, W	M5	1.0 to 1.7	M3	0.19 to 0.21
		M3	0.4 to 0.6		
F(400 V)	24V, 0V L1, L2, L3, B1, B2, B3, NC, U, V, W	M4	0.7 to 1.0	M3	0.3 to 0.5
		M5	1.0 to 1.7		
G	L1C, L2C, 24V, 0V, DB1, DB2, DB3, DB4, NC L1, L2, L3, B1, B2, NC, U, V, W	M5	2.0 to 2.4	M3	0.3 to 0.5
H	L1C, L2C, 24V, 0V, DB1, DB2 L1, L2, L3, B1, B2, NC, U, V, W	M4	0.7 to 1.0	M5	2.0 to 2.5
		M6	2.2 to 2.5		

Fastening torque list (Ground terminal screw/Connector to host controller [X4])

Driver frame	Ground screw		Connector to host controller (X4)	
	Nominal size	Fastening torque (N•m)	Nominal size	Fastening torque (N•m)
A to E	M4	0.7 to 0.8	M2.6	0.3 to 0.35
G	M5	1.4 to 1.6		
H	M6	2.4 to 2.6		

<Caution>

- Applying fastening torque larger than the maximum value may result in damage to the product.
- Do not turn on power without tightening all terminal block screws properly, otherwise, loose contacts may generate heat (smoking, firing).

<Remarks>

- To check for looseness, conduct periodic inspection of fastening torque once a year.

# A5 Family

## Table of Part Numbers and Options

## 50 W to 750 W (MSMD, MHMD: IP65) (MSME : IP67)

Motor series	Motor				Driver			Power capacity (at rated load) (kVA)	Optional parts															
	Power supply	Output (W)	Part No. (Note) 1	Rating/Spec. (page)	A5II series A5 series Part No. (Speed, Position, Torque, Full-Closed type) (Note) 2	A5IE series A5E series Part No. (Position control type) (Note) 3,4	Frame		Encoder Cable		Motor Cable		Brake Cable (Note) 5	External Regenerative Resistor	Reactor (Single phase) (3-phase)	Noise Filter (Single phase) (3-phase)								
									20-bit Incremental (Note) 5	17-bit Absolute (Note) 4,5	without Brake (Note) 5	with Brake (Note) 5												
Low inertia	MSMD (Leadwire type) 3000 r/min	Single phase 100 V	50	MSMD5AZ □ 1 *	49	MAD ◇ T1105	MAD ◇ T1105E	A-frame	MFECA 0 ** 0EAM	MFECA 0 ** 0EAE (Note) 7	MFMCB 0 ** 0EED	MFMCB 0 ** 0GET	DV0P4280	DV0P227	DV0P4170									
			100	MSMD011 □ 1 *	51	MAD ◇ T1107	MAD ◇ T1107E	A-frame																
			200	MSMD021 □ 1 *	53	MBD ◇ T2110	MBD ◇ T2110E	B-frame																
		400	MSMD041 □ 1 *	55	MCD ◇ T3120	MCD ◇ T3120E	C-frame	MFCA 0 ** 0EED								MFCA 0 ** 0EAE (Note) 7	MFMCB 0 ** 0GET	DV0P4281	DV0P227	DV0P4170				
		100	MSMD012 □ 1 *	52	MAD ◇ T1505	MAD ◇ T1505E	A-frame																	
		200	MSMD022 □ 1 *	54	MAD ◇ T1507	MAD ◇ T1507E	A-frame																	
		400	MSMD042 □ 1 *	56	MBD ◇ T2510	MBD ◇ T2510E	B-frame																	
	750	MSMD082 □ 1 *	57	MCD ◇ T3520	MCD ◇ T3520E	C-frame	MFCA 0 ** 0MJD (For movable, direction of motor shaft)	MFCA 0 ** 0MJE (For movable, direction of motor shaft)					MFMCB 0 ** 0PJT (For movable, direction of motor shaft)	DV0P4280	DV0P227	DV0P4170								
	50	MSME5AZ □ 1 *	65	MAD ◇ T1105	MAD ◇ T1105E	A-frame																		
	100	MSME011 □ 1 *	67	MAD ◇ T1107	MAD ◇ T1107E	A-frame																		
	200	MSME021 □ 1 *	69	MBD ◇ T2110	MBD ◇ T2110E	B-frame																		
	400	MSME041 □ 1 *	71	MCD ◇ T3120	MCD ◇ T3120E	C-frame																		
	MSME (Connector type) 3000 r/min	Single phase 100 V	50	MSME5AZ □ 1 *	66	MAD ◇ T1505											MAD ◇ T1505E	A-frame	MFCA 0 ** 0MKD (For movable, opposite direction of motor shaft)	MFCA 0 ** 0MKE (For movable, opposite direction of motor shaft)	MFMCB 0 ** 0PKT (For movable, opposite direction of motor shaft)	DV0P4283	DV0P228	DV0P20042
			100	MSME012 □ 1 *	68	MAD ◇ T1505											MAD ◇ T1505E	A-frame						
200			MSME022 □ 1 *	70	MAD ◇ T1507	MAD ◇ T1507E	A-frame																	
400		MSME042 □ 1 *	72	MBD ◇ T2510	MBD ◇ T2510E	B-frame																		
750		MSME082 □ 1 *	73	MCD ◇ T3520	MCD ◇ T3520E	C-frame	MFCA 0 ** 0RJD (For fixed, direction of motor shaft)	MFCA 0 ** 0TJE (For fixed, direction of motor shaft)	MFMCB 0 ** 0SJT (For fixed, direction of motor shaft)	DV0P4281	DV0P227	DV0P4170												
50		MSME5AZ □ 1 *	66	MAD ◇ T1505	MAD ◇ T1505E	A-frame																		
100		MSME012 □ 1 *	68	MAD ◇ T1505	MAD ◇ T1505E	A-frame																		
200	MSME022 □ 1 *	70	MAD ◇ T1507	MAD ◇ T1507E	A-frame																			
400	MSME042 □ 1 *	72	MBD ◇ T2510	MBD ◇ T2510E	B-frame	MFCA 0 ** 0RKD (For fixed, opposite direction of motor shaft)	MFCA 0 ** 0TKE (For fixed, opposite direction of motor shaft)	MFMCB 0 ** 0SKT (For fixed, opposite direction of motor shaft)	DV0P4283	DV0P228	DV0P20042													
750	MSME082 □ 1 *	73	MCD ◇ T3520	MCD ◇ T3520E	C-frame																			
High inertia	MHMD (Leadwire type) 3000 r/min	Single phase 100 V	200	MHMD021 □ 1 *	59	MBD ◇ T2110	MBD ◇ T2110E	B-frame	MFECA 0 ** 0EAM	MFECA 0 ** 0EAE (Note) 7	MFMCB 0 ** 0EED	MFMCB 0 ** 0GET	DV0P4283	DV0P228	DV0P4170									
			400	MHMD041 □ 1 *	61	MCD ◇ T3120	MCD ◇ T3120E	C-frame																
		Single phase/3-phase 200 V	200	MHMD022 □ 1 *	60	MAD ◇ T1507	MAD ◇ T1507E	A-frame					MFCA 0 ** 0EED	MFCA 0 ** 0EAE (Note) 7	MFMCB 0 ** 0GET	DV0P4283	DV0P228	DV0P20042						
			400	MHMD042 □ 1 *	62	MBD ◇ T2510	MBD ◇ T2510E	B-frame																
			750	MHMD082 □ 1 *	63	MCD ◇ T3520	MCD ◇ T3520E	C-frame																

Note) 1 Rotary encoder specifications: □ Motor specification: \* (refer to P.16)

Note) 2 ◇ : Drivers series K: A5II series H: A5 series

Note) 3 ◇ : Drivers series K: A5IE series H: A5E series

Note) 4 Because A5IE, A5E series drivers (dedicated for position control) do not support the 17-bit absolute specification, only 20-bit incremental type can be used in combination.

Note) 5 Cable length: \*\* (03: 3 m, 05: 5 m, 10: 10 m, 20: 20 m) (Example. 3 m: MFECA0030EAM)

Note) 6 Cables for opposite to output shaft cannot be used with 50 W or 100 W motor.

Note) 7 When you use a 17-bit absolute encoder as an incremental encoder, please use the encoder cable MFECA0\*\*0EAD.

### • Selection of cable for MSME motor (Movable: For application where the cable is movable.) (Fixed: For application where the cable is fixed.)

#### • Encoder cable

Example: MFECA0\*\*0 ◇ △ □

Symbol	Specifications	△ : Cable direction	□ : Encoder Specifications
M	Movable	J	Direction of motor shaft
T	Fixed	K	Opposite direction of motor shaft
		D	20-bit Incremental
		E	17-bit Absolute

#### • Motor cable

Example: MFMCA0\*\*0 ◇ △ D

Symbol	Specifications	△ : Cable direction	
N	Movable	J	Direction of motor shaft
R	Fixed	K	Opposite direction of motor shaft

#### • Brake cable

Example: MFMCB0\*\*0 ◇ △ T

Symbol	Specifications	△ : Cable direction	
P	Movable	J	Direction of motor shaft
S	Fixed	K	Opposite direction of motor shaft

### • Options

Title	Part No.	Page		
Interface Cable	DV0P4360	197		
Interface Conversion Cable	DV0P4120			
	DV0P4121			
	DV0P4130			
	DV0P4131			
Connector Kit for Power Supply Input Connection	DV0PM20032	200		
	DV0PM20033			
Connector Kit for Motor Connection	DV0PM20034	201		
	DV0P4290			
Connector Kit for Motor/Encoder Connection	DV0P4380	202		
	DV0PM20035			
	DV0P4170			
Connector Kit for Motor/Brake Connection	DV0PM20040	206		
	DV0P4282			
Connector Kit	RS485, RS232	DV0PM20024	198	
	Safety	DV0PM20025		
	Interface	DV0P4350		
	External Scale	DV0PM20026		
	Encoder	DV0PM20010		
Analog Monitor Signal	DV0PM20031	199		
	DV0P2990			
Battery For Absolute Encoder	DV0P2990	207		
Battery Box	DV0P4430	208		
Mounting Bracket	A-frame		DV0PM20027	
	B-frame		DV0PM20028	
	C-frame	DV0PM20029		
Encoder Cable	without Battery Box	MFECA0**0EAD	188	
		MFECA0**0EAM		
		MFECA0**0MJD		
	with Battery Box	MFECA0**0MKD		189
		MFECA0**0TJD		
Motor Cable	without Brake	MFECA0**0EAE	188	
		MFECA0**0MJE		
		MFECA0**0MKE		189
		MFECA0**0TJE		
		MFECA0**0TKE		
Brake Cable		MFMCB0**0GET	196	
		MFMCB0**0PJT		
		MFMCB0**0PKT		
		MFMCB0**0SJT		
		MFMCB0**0SKT		
External Regenerative Resistor	50 Ω 25 W	DV0P4280	210	
	100 Ω 25 W	DV0P4281		
	25 Ω 50 W	DV0P4282		
	50 Ω 50 W	DV0P4283		
	30 Ω 100 W	DV0P4284		
20 Ω 130 W	DV0P4285			
Reactor		DV0P220, DV0P221, DV0P222, DV0P223, DV0P224, DV0P225, DV0P227, DV0P228, DV0P20047	209	
		DV0P4170, DV0PM20042, DV0P4220, DV0PM20043		
		DV0P3410		251
Surge Absorber	Single phase	DV0P4190	253	
Noise Filter for Signal Lines	3-phase (200 V)	DV0P1450	254	
		DV0P1460		

Motor series	Motor					Driver			Power capacity (at rated load) (kVA)	Optional parts											
	Power supply	Output (W)	Part No. (Note) 1	Rating/ Spec. (page)	A5II series A5 series Part No. (Speed, Position, Torque, Full-Closed type) (Note) 2	A5IE series A5E series Part No. (Position control type) (Note) 3,4	Frame	Encoder Cable		Motor Cable		Brake Cable (Note) 5	External Regenerative Resistor	Reactor (Single phase 3-phase)	Noise Filter						
								20-bit Incremental (Note) 5		17-bit Absolute (Note) 4,5	without Brake (Note) 5					with Brake (Note) 5					
Low inertia  MSME 3000 r/min	Single phase/ 3-phase 200 V	1000	MSME102 □ C *	74	MDD ◇ T5540	MDD ◇ T5540E	D-frame	Approx. 1.8	MFECA 0**0ESD	MFECA 0**0ESE		-	DV0P4284	DV0P228 DV0P222	DV0P4220						
		1500	MSME152 □ C *	75	MDD ◇ T5540	MDD ◇ T5540E								DV0P228 DV0P222							
	3-phase 200 V	2000	MSME202 □ C *	76	MED ◇ T7364	MED ◇ T7364E	E-frame	Approx. 3.3						DV0P228 DV0P222	DV0P20043						
		3000	MSME302 □ C *	77	MFD ◇ TA390	MFD ◇ TA390E	F-frame	Approx. 4.5						DV0P228 DV0P222							
		4000	MSME402 □ C *	78	MFD ◇ TB3A2	MFD ◇ TB3A2E		Approx. 6						DV0P228 DV0P222							
	3-phase 400 V	5000	MSME502 □ C *	79	MFD ◇ TB3A2	MFD ◇ TB3A2E	F-frame	Approx. 7.5						DV0P228 DV0P222	DV0P3410						
		750	MSME084 □ C *	104	MDD ◇ T2412	MDD ◇ T2412E		D-frame						Approx. 1.6		-					
		1000	MSME104 □ C *	105	MDD ◇ T3420	MDD ◇ T3420E	Approx. 1.8							MFECA 0**0ESD			MFECA 0**0ESE				
		1500	MSME154 □ C *	106	MDD ◇ T3420	MDD ◇ T3420E	Approx. 2.3														
		2000	MSME204 □ C *	107	MED ◇ T4430	MED ◇ T4430E	E-frame	Approx. 3.3													
	3000	MSME304 □ C *	108	MFD ◇ T5440	MFD ◇ T5440E	F-frame	Approx. 4.5	-						DV0P224 DV0P225							
	4000	MSME404 □ C *	109	MFD ◇ TA464	MFD ◇ TA464E		Approx. 6														
	5000	MSME504 □ C *	110	MFD ◇ TA464	MFD ◇ TA464E	F-frame	Approx. 7.5														
	Middle inertia  MDME 2000 r/min	Single phase/ 3-phase 200 V	1000	MDME102 □ C *	80	MDD ◇ T3530	MDD ◇ T3530E	D-frame						Approx. 1.8	MFECA 0**0ESD	MFECA 0**0ESE		-	DV0P4284	DV0P228 DV0P222	DV0P4220
			1500	MDME152 □ C *	81	MDD ◇ T5540	MDD ◇ T5540E													DV0P228 DV0P222	
3-phase 200 V		2000	MDME202 □ C *	82	MED ◇ T7364	MED ◇ T7364E	E-frame	Approx. 3.3	DV0P228 DV0P222	DV0P20043											
		3000	MDME302 □ C *	83	MFD ◇ TA390	MFD ◇ TA390E	F-frame	Approx. 4.5	DV0P228 DV0P222												
		4000	MDME402 □ C *	84	MFD ◇ TB3A2	MFD ◇ TB3A2E		Approx. 6	DV0P228 DV0P222												
3-phase 400 V		5000	MDME502 □ C *	85	MFD ◇ TB3A2	MFD ◇ TB3A2E	F-frame	Approx. 7.5	DV0P228 DV0P222	DV0P3410											
		400	MDME044 □ C *	111	MDD ◇ T2407	MDD ◇ T2407E		D-frame	Approx. 0.9		-										
		600	MDME064 □ C *	112	MDD ◇ T2407	MDD ◇ T2407E	Approx. 1.2		MFECA 0**0ESD			MFECA 0**0ESE									
		1000	MDME104 □ C *	113	MDD ◇ T2412	MDD ◇ T2412E	Approx. 1.8														
		1500	MDME154 □ C *	114	MDD ◇ T3420	MDD ◇ T3420E	E-frame	Approx. 2.3													
2000		MDME204 □ C *	115	MED ◇ T4430	MED ◇ T4430E	F-frame	Approx. 3.3	-	DV0P224 DV0P225												
3000		MDME304 □ C *	116	MFD ◇ T5440	MFD ◇ T5440E		Approx. 4.5														
4000		MDME404 □ C *	117	MFD ◇ TA464	MFD ◇ TA464E	F-frame	Approx. 6														
5000		MDME504 □ C *	118	MFD ◇ TA464	MFD ◇ TA464E	F-frame	Approx. 7.5														
Low speed/ High torque type  MGME 1000 r/min		Single phase/ 3-phase 200 V	900	MGME092 □ C *	92	MDD ◇ T5540	MDD ◇ T5540E	D-frame	Approx. 1.8	MFECA 0**0ESD	MFECA 0**0ESE		-	DV0P4284						DV0P228 DV0P221	DV0P4220
	2000		MGME202 □ C *	93	MFD ◇ TA390	MFD ◇ TA390E	F-frame	Approx. 3.8	DV0P228 DV0P221												
	3000	MGME302 □ C *	94	MFD ◇ TB3A2	MFD ◇ TB3A2E	Approx. 4.5		DV0P228 DV0P221													
	3-phase 400 V	900	MGME094 □ C *	125	MDD ◇ T3420	MDD ◇ T3420E	D-frame	Approx. 1.8	MFECA 0**0ESD						MFECA 0**0ESE	-	DV0P4284	-	Recommended components P.252		
		2000	MGME204 □ C *	126	MFD ◇ T5440	MFD ◇ T5440E	F-frame	Approx. 3.8													
		3000	MGME304 □ C *	127	MFD ◇ TA464	MFD ◇ TA464E		Approx. 4.5													
High inertia  MHME 2000 r/min	Single phase/ 3-phase 200 V	1000	MHME102 □ C *	97	MDD ◇ T3530	MDD ◇ T3530E	D-frame	Approx. 1.8	MFECA 0**0ESD	MFECA 0**0ESE		-	DV0P4284	DV0P228/ DV0P222	DV0P4220						
		1500	MHME152 □ C *	98	MDD ◇ T5540	MDD ◇ T5540E								DV0P228/ DV0P222							
	3-phase 200 V	2000	MHME202 □ C *	99	MED ◇ T7364	MED ◇ T7364E	E-frame	Approx. 3.3						DV0P228 DV0P222	DV0P20043						
		3000	MHME302 □ C *	100	MFD ◇ TA390	MFD ◇ TA390E	F-frame	Approx. 4.5						DV0P228 DV0P222							
		4000	MHME402 □ C *	101	MFD ◇ TB3A2	MFD ◇ TB3A2E		Approx. 6						DV0P228 DV0P222							
	3-phase 400 V	5000	MHME502 □ C *	102	MFD ◇ TB3A2	MFD ◇ TB3A2E	F-frame	Approx. 7.5						DV0P228 DV0P222	DV0P3410						
		1000	MHME104 □ C *	130	MDD ◇ T2412	MDD ◇ T2412E		D-frame						Approx. 1.8		-					
		1500	MHME154 □ C *	131	MDD ◇ T3420	MDD ◇ T3420E	Approx. 2.3							MFECA 0**0ESD			MFECA 0**0ESE				
		2000	MHME204 □ C *	132	MED ◇ T4430	MED ◇ T4430E	E-frame	Approx. 3.3													
		3000	MHME304 □ C *	133	MFD ◇ T5440	MFD ◇ T5440E	F-frame	Approx. 4.5								-		DV0P224 DV0P225			
	4000	MHME404 □ C *	134	MFD ◇ TA464	MFD ◇ TA464E	Approx. 6															
	5000	MHME504 □ C *	135	MFD ◇ TA464	MFD ◇ TA464E	F-frame	Approx. 7.5														

Note) 1 Rotary encoder specifications: □ Motor specification: \* (refer to P.16)  
 Note) 2 ◇ : Drivers series K: A5II series H: A5 series Note) 3 ◇ : Drivers series K: A5IE series H: A5E series  
 Note) 4 Because A5IE, A5E series drivers (dedicated for position control) do not support the 17-bit absolute specification, only 20-bit incremental type can be used in combination.

Note) 5 Cable length: \*\* (03: 3 m, 05: 5 m, 10: 10 m, 20: 20 m),  
 (Example. 3 m: MFECA0030EAM)  
 Note) 6 Other combinations exist, and refer to P.210 for details.  
 Note) 7 Reactor should be prepared by the user.

Options (IP65 motor)			Title	Part No.	Page
Interface Cable			Interface Cable	DV0P4360	197
			Interface Conversion Cable	DV0P4120	
				DV0P4121	
				DV0P4130	
Connector Kit for Power Supply Input Connection	A to D-frame	Single row type	-	DV0PM20032	200
		Double row type		DV0PM20033	
	E-frame (200 V)	-	DV0PM20044		
			D-frame (400 V)	DV0PM20051	
			E-frame (400 V)	DV0PM20052	
Connector Kit for Control Power Supply Input Connection	D, E-frame (400 V)		-	DV0PM20053	201
	A to D-frame			DV0PM20034	
	E-frame (200 V)			DV0PM20046	
	D-frame (400 V)			DV0PM20054	
Connector Kit for Motor Connection	E-frame		-	DV0PM20045	201
	D-frame (400 V)			DV0PM20055	
Connector Kit for Regenerative Resistor	E-frame		-	DV0PM20045	204
	D-frame (400 V)			DV0PM20055	
	D, E-frame (400 V)			DV0PM20053	
Connector Kit for Motor/Encoder Connection	D, E-frame (400 V)		-	DV0P4310	205
	E-frame (200 V)			DV0P4320	
	D-frame (400 V)			DV0P4330	
	E-frame (400 V)			DV0P4340	
Connector Kit	RS485, RS232 Safety Interface	-	-	DV0PM20024	198
				DV0P4350	
				DV0PM20026	
				DV0PM20010	
				DV0PM20031	
Battery For Absolute Encoder	D, E-frame (400 V)		-	DV0P2990	207
	E-frame (200 V)			DV0P4430	
Mounting Bracket	D-frame		-	DV0PM20030	208
Encoder Cable	without Battery Box		-	MFECA0**0ESD	189
	with Battery Box			MFECA0**0ESE	190
Motor Cable	without Brake	-	-	MFMCA0**2ECD	191
				MFMC0**2ECD	192
				MFMC0**2ECD	192
				MFMC0**2ECD	192
				MFMC0**2ECD	192
				MFMC0**2ECD	192
				MFMC0**2ECD	192
with Brake	-	-	-	MFMCA0**3ECT	193
				MFMC0**3ECT	193
				MFMC0**3ECT	193
External Regenerative Resistor	50 Ω 25 W		-	DV0P4280	210
	100 Ω 25 W			DV0P4281	
	25 Ω 50 W			DV0P4282	
	50 Ω 50 W			DV0P4283	
	30 Ω 100 W			DV0P4284	
	20 Ω 130 W			DV0P4285	
	120 Ω 80 W			DV0PM20048	
	80 Ω 190 W			DV0PM20049	
	-			DV0P4286	
Reactor	DV0P220, DV0P221, DV0P222, DV0P223, DV0P224, DV0P225, DV0P227, DV0P228, DV0P20047		-	DV0P228/ DV0P222	209
	-			DV0P223	
	-			DV0P224	
Noise Filter	DV0P4170, DV0PM20042, DV0P4220, DV0PM20043		-	DV0P224 DV0P225	250
	-			DV0P225	
Surge Absorber	Single phase	-	-	DV0P4190	253
	3-phase (200 V)			DV0P1450	
	3-phase (400 V)			DV0PM20050	
Noise Filter for Signal Lines	-		-	DV0P1460	254

**A5 Family**

**Table of Part Numbers and Options**

**400 W to 15.0 kW IP67 motor (MSME MDME MFME)**

Motor					Driver			Power capacity (at rated load) (kVA)	Encoder Cable		Optional parts														
Motor series	Power supply	Output (W)	Part No. (Note) 1	Rating/Spec. (page)	A5II series A5 series Part No. (Speed, Position, Torque, Full-Closed type) (Note) 2	A5IE series A5E series Part No. (Position control type) (Note) 3,4	Frame		20-bit Incremental (Note) 5	17-bit Absolute (Note) 4,5	Motor Cable		Brake Cable (Note) 5	External Regenerative Resistor	Reactor (Single phase) (3-phase)	Noise Filter									
											without Brake (Note) 5	with Brake (Note) 5													
Low inertia	MSME	Single phase/3-phase 200 V	1000	MSME102 □ 1 *	74	MDD ◇ T5540	MDD ◇ T5540E	D-frame	MFECA 0**0ETD	MFECA 0**0ETE	MFMC D 0**2ECD	MFMC A 0**2FCD	—	DV0P4284	DV0P228	DV0P4220									
			1500	MSME152 □ 1 *	75	MDD ◇ T5540	MDD ◇ T5540E								DV0P222										
		3-phase 200 V	2000	MSME202 □ 1 *	76	MED ◇ T7364	MED ◇ T7364E	E-frame							Approx. 3.3		MFMC A 0**3ECT	MFMC A 0**3FCT	DV0P4285 (Note) 7	DV0P223	DV0P222	DV0P20047	DV0P222	DV0P20043	
			3000	MSME302 □ 1 *	77	MFD ◇ TA390	MFD ◇ TA390E	F-frame							Approx. 4.5										
			4000	MSME402 □ 1 *	78	MFD ◇ TB3A2	MFD ◇ TB3A2E								Approx. 6										
		3-phase 400 V	5000	MSME502 □ 1 *	79	MFD ◇ TB3A2	MFD ◇ TB3A2E	F-frame							Approx. 7.5		MFMC A 0**3ECT	MFMC A 0**3FCT	DV0P4285 x2 in parallel	—	DV0P224	DV0P225	—	DV0P3410	
	750		MSME084 □ 1 *	104	MDD ◇ T2412	MDD ◇ T2412E	D-frame	Approx. 1.6																	
	1000		MSME104 □ 1 *	105	MDD ◇ T3420	MDD ◇ T3420E		Approx. 1.8																	
	1500		MSME154 □ 1 *	106	MDD ◇ T3420	MDD ◇ T3420E	E-frame	Approx. 2.3																	
	2000		MSME204 □ 1 *	107	MED ◇ T4430	MED ◇ T4430E	Approx. 3.3																		
	MDME	2000 r/min	Single phase/3-phase 200 V	1000	MDME102 □ 1 *	80	MDD ◇ T3530	MDD ◇ T3530E	D-frame	MFECA 0**0ETD	MFECA 0**0ETE	MFMC D 0**2ECD	MFMC A 0**2FCD	—	DV0P4284	DV0P228	DV0P4220								
				1500	MDME152 □ 1 *	81	MDD ◇ T5540	MDD ◇ T5540E								DV0P222									
			3-phase 200 V	2000	MDME202 □ 1 *	82	MED ◇ T7364	MED ◇ T7364E	E-frame							Approx. 3.3		MFMC A 0**3ECT	MFMC A 0**3FCT	DV0P4285 (Note) 7	DV0P223	DV0P222	DV0P20047	DV0P222	DV0P20043
				3000	MDME302 □ 1 *	83	MFD ◇ TA390	MFD ◇ TA390E	F-frame							Approx. 4.5									
4000				MDME402 □ 1 *	84	MFD ◇ TB3A2	MFD ◇ TB3A2E	Approx. 6																	
5000				MDME502 □ 1 *	85	MFD ◇ TB3A2	MFD ◇ TB3A2E	Approx. 7.5																	
7500				MDME752 □ 1 *	86	MGD ◇ TC3B4	—	G-frame	Approx. 11																
11000		MDMEC12 □ 1 *	87	MHD ◇ TC3B4	—	H-frame	Approx. 17																		
15000	MDMEC52 □ 1 *	88	MHD ◇ TC3B4	—	Approx. 22																				
Middle inertia	2000 r/min	Single phase/3-phase 200 V	400	MDME044 □ 1 *	111	MDD ◇ T2407	MDD ◇ T2407E	D-frame	MFECA 0**0ETD	MFECA 0**0ETE	MFMC D 0**2ECD	MFMC E 0**2FCD	—	DV0P4285 x2 in parallel	—	DV0P20048	Recommended components P.252								
			600	MDME064 □ 1 *	112	MDD ◇ T2407	MDD ◇ T2407E											Approx. 0.9							
		3-phase 400 V	1000	MDME104 □ 1 *	113	MDD ◇ T2412	MDD ◇ T2412E	D-frame										Approx. 1.2							
			1500	MDME154 □ 1 *	114	MDD ◇ T3420	MDD ◇ T3420E											Approx. 1.8							
			2000	MDME204 □ 1 *	115	MED ◇ T4430	MED ◇ T4430E	E-frame										Approx. 3.3							
			3000	MDME304 □ 1 *	116	MFD ◇ T5440	MFD ◇ T5440E	F-frame										Approx. 4.5							
			4000	MDME404 □ 1 *	117	MFD ◇ TA464	MFD ◇ TA464E											Approx. 6							
			5000	MDME504 □ 1 *	118	MFD ◇ TA464	MFD ◇ TA464E	Approx. 7.5																	
			7500	MDME754 □ 1 *	119	MGD ◇ TB4A2	—	G-frame										Approx. 11							
			11000	MDMEC14 □ 1 *	120	MHD ◇ TB4A2	—	H-frame										Approx. 17							
15000	MDMEC54 □ 1 *	121	MHD ◇ TB4A2	—	Approx. 22																				
MFME	(Flat type) 2000 r/min	Single phase/3-phase 200 V	1500	MFME152 □ 1 *	89	MDD ◇ T5540	MDD ◇ T5540E	D-frame	MFECA 0**0ETD	MFECA 0**0ETE	MFMC A 0**2ECD	MFMC A 0**2FCD	—	DV0P4284	DV0P20047	DV0P4220									
			2500	MFME252 □ 1 *	90	MED ◇ T7364	MED ◇ T7364E								DV0P222										
		3-phase 200 V	4500	MFME452 □ 1 *	91	MFD ◇ TB3A2	MFD ◇ TB3A2E	F-frame							Approx. 6.8		MFMC F 0**2ECD	MFMC E 0**2FCD	DV0P4285 (Note) 7	DV0P224	—	DV0P20043			
			1500	MFME154 □ 1 *	122	MDD ◇ T3420	MDD ◇ T3420E	D-frame							Approx. 2.3										
		3-phase 400 V	2500	MFME254 □ 1 *	123	MED ◇ T4430	MED ◇ T4430E	E-frame							Approx. 3.8		MFMC D 0**3ECT	MFMC A 0**3FCT	DV0P4285 x2 in parallel	—	DV0P224	—	DV0P3410		
			4500	MFME454 □ 1 *	124	MFD ◇ TA464	MFD ◇ TA464E	F-frame							Approx. 6.8										

Note) 1 Rotary encoder specifications: □ Motor specification: \* (refer to P.16)  
 Note) 2 ◇ : Drivers series K: A5II series H: A5 series Note) 3 ◇ : Drivers series K: A5IE series H: A5E series  
 Note) 4 Because A5IE, A5E series drivers (dedicated for position control) do not support the 17-bit absolute specification, only 20-bit incremental type can be used in combination.  
 Note) 3 Cable length: \*\* (03: 3 m, 05: 5 m, 10: 10 m, 20: 20 m), (Example. 3 m: MFECA0030EAM)

Options (IP67 motor)			
Title	Part No.	Page	
Interface Cable	DV0P4360	197	
Interface Conversion Cable	DV0P4120		
	DV0P4121		
	DV0P4130		
Connector Kit for Power Supply Input Connection	DV0P4131	200	
	DV0P4132		
	A to D-frame Single row type		DV0PM20032
	E-frame (200 V) Double row type		DV0PM20033
	D-frame (400 V)		DV0PM20044
Connector Kit for Control Power Supply Input Connection	DV0PM20051	201	
	D-frame (400 V)		DV0PM20052
	D, E-frame (400 V)		DV0PM20053
Connector Kit for Motor Connection	DV0PM20034	201	
	E-frame (200 V)		DV0PM20046
	D-frame (400 V)		DV0PM20054
Connector Kit for Regenerative Resistor	DV0PM20045	201	
	D-frame (400 V)		DV0PM20055
Connector Kit for Motor/Encoder Connection	DV0PM20036	203	
	DV0PM20037	204	
	DV0PM20038	204	
	DV0PM20039	205	
Connector Kit	RS485, RS232	DV0PM20024	
	Safety Interface	DV0PM20025	
	External Scale	DV0P4350	
	Encoder	DV0PM20026	
	Analog Monitor Signal	DV0PM20010	
Battery For Absolute Encoder	DV0PM20031	199	
Battery Box	DV0P2990	207	
Mounting Bracket	DV0P4430	208	
Encoder Cable	D-frame	DV0PM20030	
	without Battery Box	DV0PM20030	
Motor Cable	with Battery Box	DV0PM20030	
	without Brake	MFECA0**0ETD	190
		MFMC A 0**2ECD	191
		MFMC D 0**2ECD	191
		MFMC E 0**2ECD	192
		MFMC F 0**2ECD	192
	with Brake	MFMC A 0**3ECT	193
		MFMC D 0**3ECT	193
		MFMC A 0**2FCD	194
		MFMC E 0**2FCD	194
MFMC A 0**3FCT		195	
External Regenerative Resistor	50 Ω 25 W	DV0P4280	
	100 Ω 25 W	DV0P4281	
	25 Ω 50 W	DV0P4282	
	50 Ω 50 W	DV0P4283	
	30 Ω 100 W	DV0P4284	
	20 Ω 130 W	DV0P4285	
	120 Ω 80 W	DV0P20048	
80 Ω 190 W	DV0P20049		
Reactor	DV0P220, DV0P221, DV0P222, DV0P223, DV0P224, DV0P225, DV0P227, DV0P228, DV0P20047	209	
	DV0P222, DV0P223, DV0P224, DV0P225, DV0P227, DV0P228, DV0P20047	250	
	DV0P222, DV0P223, DV0P224, DV0P225, DV0P227, DV0P228, DV0P20047		
Noise Filter	DV0P4170, DV0P20042, DV0P4220, DV0P20043	250	
	DV0P3410	251	
Surge Absorber	Single phase	DV0P4190	
	3-phase (200V)	DV0P1450	
	3-phase (400V)	DV0PM20050	
Noise Filter for Signal Lines	DV0P1460	254	

Note) 6 Recommend to get the connector kit of options.  
 Note) 7 Other combinations exist, and refer to P.210 for details.  
 Note) 8 Reactor should be prepared by the user.

# A5 Family

## Table of Part Numbers and Options

### 0.9 kW to 7.5 kW IP67 motor (MGME/MHME)

Motor					Driver			Power capacity (at rated load) (kVA)	Optional parts													
Motor series	Power supply	Output (W)	Part No. (Note 1)	Rating/Spec. (page)	A5II series A5 series Part No. (Speed, Position, Torque, Full-Closed type) (Note 2)	A5IE series A5E series Part No. (Position control type) (Note 3,4)	Frame		Encoder Cable		Motor Cable		Brake Cable (Note 5)	External Regenerative Resistor	Reactor (Single phase) (3-phase)	Noise Filter						
									20-bit Incremental (Note 5)	17-bit Absolute (Note 4,5)	without Brake (Note 5)	with Brake (Note 5)										
Middle inertia	MGME (Low speed/ High torque type) 1000 r/min	Single phase/ 3-phase 200 V	900	MGME092 □ 1 *	92	MDD ◇ T5540	MDD ◇ T5540E	D-frame	Approx. 1.8	MFECA 0**0ETD	MFECA 0**0ETE	—	DV0P4284	DV0P228 DV0P221	DV0P4220							
		3-phase 200 V	2000	MGME202 □ 1 *	93	MFD ◇ TA390	MFD ◇ TA390E	F-frame	Approx. 3.8					MFCA 0**3ECT		MFCA 0**3FCT	—	DV0P4285 x2 in parallel	DV0P223 DV0P224	DV0P3410		
			3000	MGME302 □ 1 *	94	MFD ◇ TB3A2	MFD ◇ TB3A2E		Approx. 4.5													
			4500	MGME452 □ 1 *	95	MFD ◇ TB3A2	MFD ◇ TB3A2E	Approx. 7.5														
			6000	MGME602 □ 1 *	96	MGD ◇ TC3B4	—	G-frame	Approx. 9.0					— (Note 6)		— (Note 6)	—	DV0P4285 x3 in parallel	— (Note 7)	Recommended components P.252		
		3-phase 400 V	900	MGME094 □ 1 *	125	MDD ◇ T3420	MDD ◇ T3420E	D-frame	Approx. 1.8					MFECA 0**0ETD		MFECA 0**0ETE	—	MFCA 0**3ECT	MFCE 0**2FCD	—	DV0PM20048	Recommended components P.252
	2000		MGME204 □ 1 *	126	MFD ◇ T5440	MFD ◇ T5440E	F-frame	Approx. 3.8														
	3000		MGME304 □ 1 *	127	MFD ◇ TA464	MFD ◇ TA464E		Approx. 4.5														
	4500		MGME454 □ 1 *	128	MFD ◇ TA464	MFD ◇ TA464E	Approx. 7.5															
	6000		MGME604 □ 1 *	129	MGD ◇ TB4A2	—	G-frame	Approx. 9.0	— (Note 6)	— (Note 6)	—	DV0PM20049 x3 in parallel	— (Note 7)		Recommended components P.252							
	High inertia		MHME 2000 r/min	Single phase/ 3-phase 200 V	1000	MHME102 □ 1 *	97	MDD ◇ T3530	MDD ◇ T3530E	D-frame	Approx. 1.8	MFECA 0**0ETD	MFECA 0**0ETE		—						DV0P4284	
		1500		MHME152 □ 1 *	98	MDD ◇ T5540	MDD ◇ T5540E	Approx. 2.3	DV0PM20047 DV0P222													
3-phase 200 V		2000		MHME202 □ 1 *	99	MED ◇ T7364	MED ◇ T7364E	E-frame	Approx. 3.3	MFCA 0**3ECT	MFCE 0**2FCD			—		DV0P4285 x2 in parallel	DV0P223	DV0P20043				
		3000		MHME302 □ 1 *	100	MFD ◇ TA390	MFD ◇ TA390E	F-frame	Approx. 4.5													
		4000		MHME402 □ 1 *	101	MFD ◇ TB3A2	MFD ◇ TB3A2E		Approx. 6													
		5000		MHME502 □ 1 *	102	MFD ◇ TB3A2	MFD ◇ TB3A2E	Approx. 7.5														
		7500		MHME752 □ 1 *	103	MGD ◇ TC3B4	—	G-frame	Approx. 11								— (Note 6)		— (Note 6)	—		DV0P4285 x3 in parallel
3-phase 400 V		1000		MHME104 □ 1 *	130	MDD ◇ T2412	MDD ◇ T2412E	D-frame	Approx. 1.8	MFECA 0**0ETD	MFCE 0**2FCD			—		MFCA 0**3ECT	MFCA 0**3FCT	—	DV0PM20048	Recommended components P.252		
		1500		MHME154 □ 1 *	131	MDD ◇ T3420	MDD ◇ T3420E		Approx. 2.3													
		2000	MHME204 □ 1 *	132	MED ◇ T4430	MED ◇ T4430E	E-frame	Approx. 3.3														
		3000	MHME304 □ 1 *	133	MFD ◇ T5440	MFD ◇ T5440E	F-frame	Approx. 4.5														
		4000	MHME404 □ 1 *	134	MFD ◇ TA464	MFD ◇ TA464E		Approx. 6														
		5000	MHME504 □ 1 *	135	MFD ◇ TA464	MFD ◇ TA464E	Approx. 7.5															
		7500	MHME754 □ 1 *	136	MGD ◇ TB4A2	—	G-frame	Approx. 9.0	— (Note 6)			— (Note 6)	—		DV0PM20049 x3 in parallel				— (Note 7)		Recommended components P.252	

- Note 1 Rotary encoder specifications: □ Motor specification: \* (refer to P.16)  
 Note 2 ◇ : Drivers series K: A5II series H: A5 series  
 Note 3 ◇ : Drivers series K: A5IE series H: A5E series  
 Note 4 Because A5IE, A5E series drivers (dedicated for position control) do not support the 17-bit absolute specification, only 20-bit incremental type can be used in combination.  
 Note 5 Cable length: \*\* (03: 3 m, 05: 5 m, 10: 10 m, 20: 20 m), (Example. 3 m: MFECA0030EAM)  
 Note 6 Recommend to get the connector kit of options.  
 Note 7 Reactor should be prepared by the user.  
 Note 8 Other combinations exist, and refer to P.210 for details.

Options (IP67 motor)		
Title	Part No.	Page
Interface Cable	DV0P4360	197
Interface Conversion Cable	DV0P4120	
	DV0P4121	
	DV0P4130	
	DV0P4131	
Connector Kit for Power Supply Input Connection	DV0PM20032	200
	DV0PM20033	
	DV0PM20044	
	DV0PM20051	
Connector Kit for Control Power Supply Input Connection	DV0PM20052	201
	D, E-frame (400 V)	
Connector Kit for Motor Connection	DV0PM20053	201
	A to D-frame	
	E-frame (200 V)	
Connector Kit for Regenerative Resistor	DV0PM20034	201
	DV0PM20046	
Connector Kit for Regenerative Resistor	DV0PM20054	201
	DV0PM20045	
Connector Kit for Regenerative Resistor	DV0PM20055	203
	DV0PM20036	
Connector Kit for Motor/Encoder Connection	DV0PM20037	204
	DV0PM20038	
	DV0PM20039	
	DV0PM20047	
Connector Kit	DV0P222	198
	RS485, RS232	
	Safety	
	Interface	
	External Scale	
Connector Kit	DV0PM20024	199
	DV0PM20025	
	DV0P4350	
	DV0PM20026	
Connector Kit	DV0PM20010	199
	DV0PM20031	
Battery For Absolute Encoder	DV0P2990	207
Battery Box	DV0P4430	207
Mounting Bracket	DV0PM20030	208
Encoder Cable	without Battery Box	190
	with Battery Box	
Motor Cable	MFMCA0**2ECD	191
	MFMCD0**2ECD	
	MFMCE0**2ECD	
	MFMCF0**2ECD	
	MFMCA0**3ECT	
	MFMCD0**3ECT	
	MFMCE0**3ECT	
Motor Cable	MFMCA0**2FCD	194
	MFMCE0**2FCD	
	MFMCA0**3FCT	
External Regenerative Resistor	50 Ω 25 W	210
	100 Ω 25 W	
	25 Ω 50 W	
	50 Ω 50 W	
	30 Ω 100 W	
	20 Ω 130 W	
	120 Ω 80 W	
	80 Ω 190 W	
Reactor	DV0P220, DV0P221, DV0P222, DV0P223, DV0P224, DV0P225, DV0P227, DV0P228, DV0PM20047	209
	DV0P4170, DV0PM20042, DV0P4220, DV0PM20043	
	DV0P3410	
	Single phase	
	DV0P4190	
Surge Absorber	3-phase (200 V)	253
	DV0P1450	
	3-phase (400 V)	
DV0PM20050	251	
Noise Filter for Signal Lines		
DV0P1460	254	

Basic Specifications	Input power	100 V	Main circuit	Single phase, 100 V to 120 V	+10 % -15 %	50/60 Hz		
			Control circuit	Single phase, 100 V to 120 V	+10 % -15 %	50/60 Hz		
		200 V	Main circuit	A to D-frame	Single/3-phase, 200 V to 240 V	+10 % -15 %	50/60 Hz	
				E to H-frame	3-phase, 200 V to 230 V	+10 % -15 %	50/60 Hz	
			Control circuit	A to D-frame	Single phase, 200 V to 240 V	+10 % -15 %	50/60 Hz	
				E to H-frame	Single phase, 200 V to 230 V	+10 % -15 %	50/60 Hz	
		400 V	Main circuit	D to H-frame	3-phase, 380 V to 480 V	+10 % -15 %	50/60 Hz	
			Control circuit	D to H-frame	DC 24 V ± 15 %			
		Environment	temperature	Ambient temperature: 0 °C to 55 °C (free from freezing) Storage temperature: -20 °C to 65 °C (Max.temperature guarantee: 80 °C for 72 hours free from condensation <sup>*1</sup> )				
			humidity	Both operating and storage : 20 % to 85 %RH (free from condensation <sup>*1</sup> )				
			Altitude	Lower than 1000 m				
			Vibration	5.88 m/s <sup>2</sup> or less, 10 Hz to 60 Hz (No continuous use at resonance frequency)				
	Control method		IGBT PWM Sinusoidal wave drive					
	Encoder feedback		17-bit (131072 resolution) absolute encoder, 7-wire serial 20-bit (1048576 resolution) incremental encoder, 5-wire serial					
	Feedback scale feedback	A/B phase	A/B phase, initialization signal differential input.					
		serial	Manufacturers that support serial communication scale: Mitutoyo Corporation Magnescape Co., Ltd. MicroE Systems Renishaw plc, Fagor Automation S.Coop					
	Parallel I/O connector	Control signal	Input	General purpose 10 inputs The function of general-purpose input is selected by parameters.				
			Output	General purpose 6 outputs The function of general-purpose output is selected by parameters.				
		Analog signal	Input	3 inputs (16Bit A/D : 1 input, 12Bit A/D : 2 inputs)				
			Output	2 outputs (Analog monitor: 2 output)				
	Pulse signal	Input	2 inputs (Photo-coupler input, Line receiver input)					
		Output	4 outputs ( Line driver: 3 output, open collector: 1 output)					
	Communication function	USB	Connection with PC etc.					
		RS232	1 : 1 communication					
		RS485	1 : n communication up to 31 axes to a host.					
	Safety function		Used for functional safety.					
	Front panel		(1) 5 keys (2) LED (6-digit) (3) Connector for monitor (Analog monitor output (2ch), Digital monitor output (1ch))					
	Regeneration		A, B, G and H-frame: no built-in regenerative resistor (external resistor only) C to F-frame: Built-in regenerative resistor (external resistor is also enabled.)					
Dynamic brake		A to G-frame: Built-in (external resistor is also available to G-frame) H-frame: External only						
Control mode		Switching among the following 7 mode is enabled, (1) Position control (2) Speed control (3) Toque control (4) Position/Speed control (5) Position/Torque control (6) Speed/Torque control (7) Full-closed control						

\*1 Air containing water vapor will become saturated with water vapor as the temperature falls, causing dew.

\*2 Not applicable to 2DOF control system.

Function	Position control	Control input	(1) Deviation counter clear (2) Command pulse inhibition (3) Electric gear (4) Damping control switching etc.				
		Control output	Positioning complete (In-position) etc.				
		Pulse input	Max. command pulse frequency	Exclusive interface for Photo-coupler: 500 kpps Exclusive interface for line driver : 4 Mpps			
			Input pulse signal format	Differential input ((1) Positive and Negative direction, (2) A and B-phase, (3) Command and direction)			
			Electronic gear (Division/Multiplication of command pulse)	1/1000 to 1000 times			
			Smoothing filter	Primary delay filter or FIR type filter is adaptable to the command input			
		Analog input	Torque limit command input	Individual torque limit for both positive and negative direction is enabled.			
			Torque feed forward input	Analog voltage can be used as torque feed forward input.			
		Instantaneous Speed Observer		Available			
		Damping Control		Available			
		2DOF settings		Only available at A5II Series			
		Speed control	Control input	(1) Selection of internal velocity setup 1 (2) Selection of internal velocity setup 2 (3) Selection of internal velocity setup 3 (4) Speed zero clamp etc.			
	Control output		Speed arrival etc.				
	Analog input		Velocity command input	Speed command input can be provided by means of analog voltage. Parameters are used for scale setting and command polarity. (6 V/Rated rotational speed Default)			
			Torque limit command input	Individual torque limit for both positive and negative direction is enabled.			
			Torque feed forward input	Analog voltage can be used as torque feed forward input.			
	Internal velocity command		Switching the internal 8speed is enabled by command input.				
	Soft-start/down function		Individual setup of acceleration and deceleration is enabled, with 0 to 10 s/1000 r/min. Sigmoid acceleration/deceleration is also enabled.				
	Zero-speed clamp		Speed zero clamp input is enabled.				
	Instantaneous Speed Observer		Available				
	Speed Control filter		Available				
	2DOF settings		Only available at A5II Series				
	Torque control <sup>*2</sup>		Control input	Speed zero clamp, Torque command sign input etc.			
		Control output	Speed arrival etc.				
		Analog input	Torque command input	Speed command input can be provided by means of analog voltage. Parameters are used for scale setting and command polarity. (3 V/rated torque Default)			
			Speed limit function	Speed limit value with parameter is enabled.			
	Full-closed control <sup>*2</sup>	Control input	(1) Deviation counter clear (2) Command pulse inhibition (3) Command dividing gradual increase switching (4) Damping control switching etc.				
		Control output	Full-closed positioning complete etc.				
Pulse input		Max. command pulse frequency	Exclusive interface for Photo-coupler: 500 kpps Exclusive interface for line driver : 4 Mpps				
		Input pulse signal format	Differential input				
		Electronic gear (Division/Multiplication of command pulse)	1/1000 to 1000 times				
		Smoothing filter	Primary delay filter or FIR type filter is adaptable to the command input				
Analog input		Torque limit command input	Individual torque limit for both positive and negative direction is enabled.				
		Torque feed forward input	Analog voltage can be used as torque feed forward input.				
Setup range of division/multiplication of feedback scale		1/40 to 160 times					
Damping Control		Only available at A5II Series					
Common		Auto tuning	The load inertia is identified in real time by the driving state of the motor operating according to the command given by the controlling device and set up support software "PANATERM". The gain is set automatically in accordance with the rigidity setting.				
		Division of encoder feedback pulse		Set up of any value is enabled (encoder pulses count is the max.).			
	Protective function	Hard error	Over-voltage, under-voltage, over-speed, over-load, over-heat, over-current and encoder error etc.				
		Soft error	Excess position deviation, command pulse division error, EEPROM error etc.				
	Traceability of alarm data		The alarm data history can be referred to.				



Basic Specifications	Input power	100 V	Main circuit	Single phase, 100 V to 120 V	+10 % -15 %	50/60 Hz	
			Control circuit	Single phase, 100 V to 120 V	+10 % -15 %	50/60 Hz	
		200 V	Main circuit	A to D-frame	Single/3-phase, 200 V to 240 V	+10 % -15 %	50/60 Hz
				E to F-frame	3-phase, 200 V to 230 V	+10 % -15 %	50/60 Hz
			Control circuit	A to D-frame	Single phase, 200 V to 240 V	+10 % -15 %	50/60 Hz
				E to F-frame	Single phase, 200 V to 230 V	+10 % -15 %	50/60 Hz
		400 V	Main circuit	D to F-frame	3-phase, 380 V to 480 V	+10 % -15 %	50/60 Hz
			Control circuit	D to F-frame	DC 24 V ± 15 %		
		Environment	temperature	Ambient temperature: 0 °C to 50 °C (free from freezing) Storage temperature: -20 °C to 65 °C (Max.temperature guarantee: 80 °C for 72 hours free from condensation*1)			
			humidity	Both operating and storage : 20 % to 85 %RH (free from condensation*1)			
	Altitude		Lower than 1000 m				
	Vibration		5.88 m/s <sup>2</sup> or less, 10 Hz to 60 Hz (No continuous use at resonance frequency)				
	Control method		IGBT PWM Sinusoidal wave drive				
	Encoder feedback		20-bit (1048576 resolution) incremental encoder, 5-wire serial				
	Parallel I/O connector	Control signal	Input	General purpose 10 inputs The function of general-purpose input is selected by parameters.			
			Output	General purpose 6 outputs The function of general-purpose output is selected by parameters.			
		Analog signal	Input	none			
			Output	2 outputs (Analog monitor: 2 output)			
	Pulse signal	Input	2 inputs (Photo-coupler input, Line receiver input)				
		Output	4 outputs ( Line driver: 3 output, open collector: 1 output)				
Communication function		USB	Connection with PC etc.				
Front panel		(1) 5 keys (2) LED (6-digit) (3) Analog monitor output (2ch)					
Regeneration		A, B-frame: no built-in regenerative resistor (external resistor only) C to F-frame: Built-in regenerative resistor (external resistor is also enabled.)					
Dynamic brake		Built-in					
Control mode		(1) Position control (2) Internal velocity control (3) Position/ Internal velocity control					

\*1 Air containing water vapor will become saturated with water vapor as the temperature falls, causing dew.

Function	Position control	Control input		(1) Deviation counter clear (2) Command pulse inhibition (3) Electric gear (4) Damping control switching etc.		
		Control output		Positioning complete (In-position) etc.		
		Pulse input	Max. command pulse frequency	Exclusive interface for Photo-coupler: 500 kpps Exclusive interface for line driver : 4 Mpps		
			Input pulse signal format	Differential input ((1) Positive and Negative direction, (2) A and B-phase, (3) Command and direction)		
			Electronic gear (Division/Multiplication of command pulse)	1/1000 to 1000 times		
			Smoothing filter	Primary delay filter or FIR type filter is adaptable to the command input		
		Instantaneous Speed Observer		Available		
		Damping Control		Available		
		2DOF settings		Only available at A5II Series		
		Common	Auto tuning		The load inertia is identified in real time by the driving state of the motor operating according to the command given by the controlling device and set up support software "PANATERM". The gain is set automatically in accordance with the rigidity setting.	
			Division of encoder feedback pulse		Set up of any value is enabled (encoder pulses count is the max.).	
			Protective function	Hard error	Over-voltage, under-voltage, over-speed, over-load, over-heat, over-current and encoder error etc.	
				Soft error	Excess position deviation, command pulse division error, EEPROM error etc.	
			Traceability of alarm data		The alarm data history can be referred to.	

**In Case of Single phase, A to D-frame, 100 V / 200 V type**

**In Case of MSMD, MHMD**

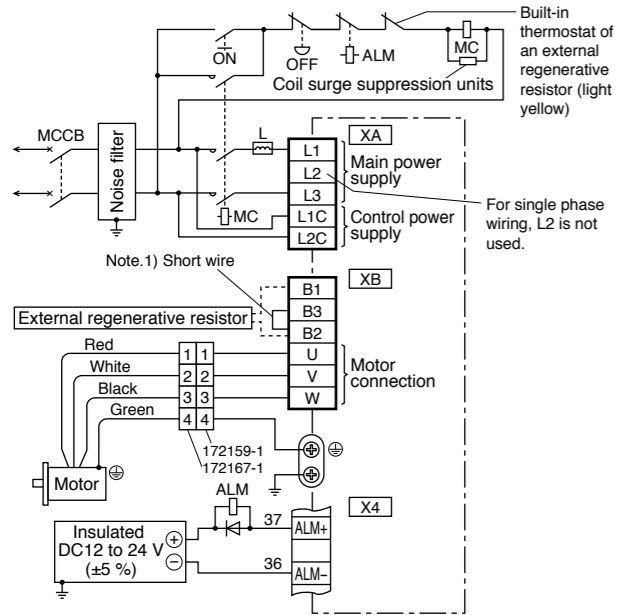

**In Case of MSME**

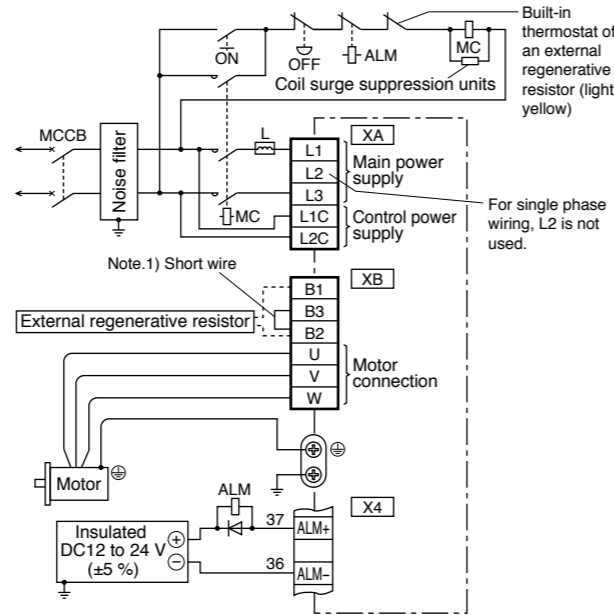

Note.1)

Frame No.	Short wire (Accessory)	Built-in regenerative resistor	Connection of the connector XB	
			In case of using an external regenerative resistor.	In case of not using an external regenerative resistor.
A-frame B-frame	without	without	<ul style="list-style-type: none"> <li>Always open between B2-B3</li> <li>Connect an external regenerative resistor between B1-B2</li> </ul>	<ul style="list-style-type: none"> <li>Always open between B2-B3</li> </ul>
C-frame D-frame	with	with	<ul style="list-style-type: none"> <li>Remove the short wire accessory from between B2-B3.</li> <li>Connect an external regenerative resistor between B1-B2</li> </ul>	<ul style="list-style-type: none"> <li>Shorted between B2-B3 with an attached short wire</li> </ul>

Note.1)

Frame No.	Short wire (Accessory)	Built-in regenerative resistor	Connection of the connector XB	
			In case of using an external regenerative resistor.	In case of not using an external regenerative resistor.
A-frame B-frame	without	without	<ul style="list-style-type: none"> <li>Always open between B2-B3</li> <li>Connect an external regenerative resistor between B1-B2</li> </ul>	<ul style="list-style-type: none"> <li>Always open between B2-B3</li> </ul>
C-frame D-frame	with	with	<ul style="list-style-type: none"> <li>Remove the short wire accessory from between B2-B3.</li> <li>Connect an external regenerative resistor between B1-B2</li> </ul>	<ul style="list-style-type: none"> <li>Shorted between B2-B3 with an attached short wire</li> </ul>

**In Case of 3-phase, A to D-frame, 200 V type**

**In Case of MSMD, MHMD**

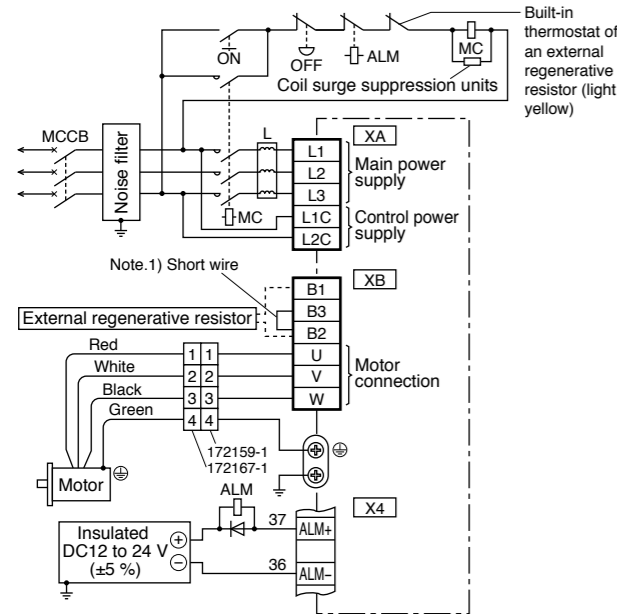

**In Case of MSME**

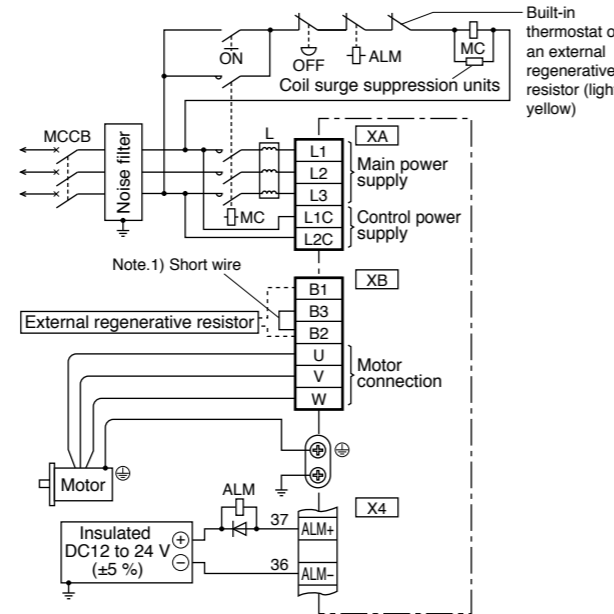

Note.1)

Frame No.	Short wire (Accessory)	Built-in regenerative resistor	Connection of the connector XB	
			In case of using an external regenerative resistor.	In case of not using an external regenerative resistor.
A-frame B-frame	without	without	<ul style="list-style-type: none"> <li>Always open between B2-B3</li> <li>Connect an external regenerative resistor between B1-B2</li> </ul>	<ul style="list-style-type: none"> <li>Always open between B2-B3</li> </ul>
C-frame D-frame	with	with	<ul style="list-style-type: none"> <li>Remove the short wire accessory from between B2-B3.</li> <li>Connect an external regenerative resistor between B1-B2</li> </ul>	<ul style="list-style-type: none"> <li>Shorted between B2-B3 with an attached short wire</li> </ul>

Note.1)

Frame No.	Short wire (Accessory)	Built-in regenerative resistor	Connection of the connector XB	
			In case of using an external regenerative resistor.	In case of not using an external regenerative resistor.
A-frame B-frame	without	without	<ul style="list-style-type: none"> <li>Always open between B2-B3</li> <li>Connect an external regenerative resistor between B1-B2</li> </ul>	<ul style="list-style-type: none"> <li>Always open between B2-B3</li> </ul>
C-frame D-frame	with	with	<ul style="list-style-type: none"> <li>Remove the short wire accessory from between B2-B3.</li> <li>Connect an external regenerative resistor between B1-B2</li> </ul>	<ul style="list-style-type: none"> <li>Shorted between B2-B3 with an attached short wire</li> </ul>

\* Refer to P.186, P.187, Specifications of Motor connector.

**In Case of 3-phase, E-frame, 200 V type**

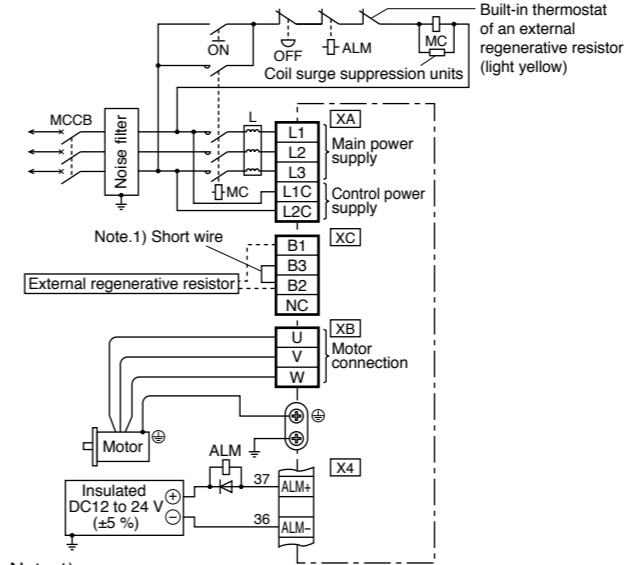

Note.1)

Frame No.	Short wire (Accessory)	Built-in regenerative resistor	Connection of the connector XC	
			In case of using an external regenerative resistor.	In case of not using an external regenerative resistor.
E-frame	with	with	<ul style="list-style-type: none"> <li>Remove the short wire accessory from between B2-B3.</li> <li>Connect an external regenerative resistor between B1-B2</li> </ul>	<ul style="list-style-type: none"> <li>Shorted between B2-B3 with an attached short wire</li> </ul>

**In Case of 3-phase, G-frame, 200 V type**

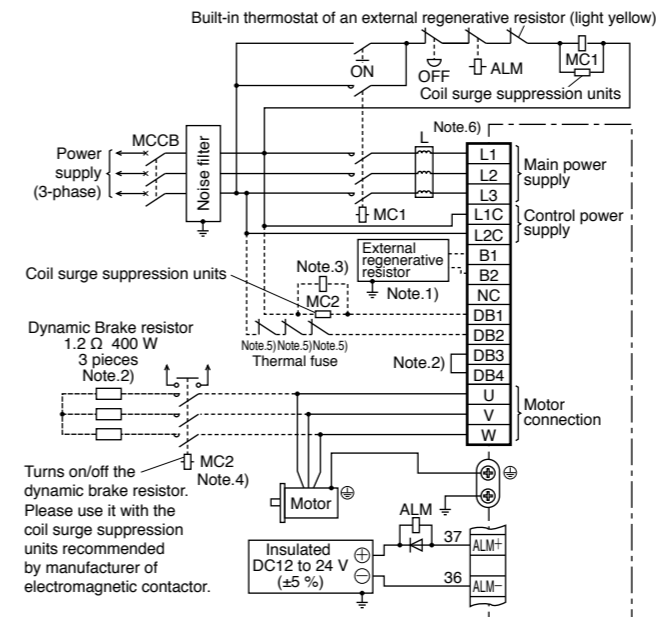

Note.1) About regenerative resistor

Frame No.	Short bar (Accessory)	Built-in regenerative resistor	Connection of terminal block	
			In case of using an external regenerative resistor.	In case of not using an external regenerative resistor.
G-frame	without	without	<ul style="list-style-type: none"> <li>Connect an external regenerative resistor between B1-B2</li> </ul>	<ul style="list-style-type: none"> <li>Open between B1-B2</li> </ul>

Note.2) About dynamic brake resistor

Frame No.	Short bar (Accessory)	Built-in dynamic brake resistor.	Connection of terminal block	
			In case of using an external dynamic brake resistor.	In case of not using an external dynamic brake resistor.
G-frame	with	with	<ul style="list-style-type: none"> <li>Remove attached short bar between DB3-DB4.</li> <li>Connect external dynamic brake resistor as shown above.</li> </ul>	<ul style="list-style-type: none"> <li>Shorted with attached short bar between DB3-DB4</li> <li>Open between DB1-DB2</li> </ul>

<common for G & H frame>

- Note.3) Magnetic contactor MC2 must be the same rating as the contactor MC1 in the main circuit.
- Note.4) Servo may be turned on in the internal sequence if the contact deposits: to protect the system, provide the auxiliary contact.
- Note.5) Provide an external protective device (e.g. thermal fuse) to monitor the temperature of the external dynamic brake resistor.
- Note.6) Reactor should be prepared by the customer.

\* Refer to P.186, P.187, Specifications of Motor connector.

**In Case of 3-phase, F-frame, 200 V type**

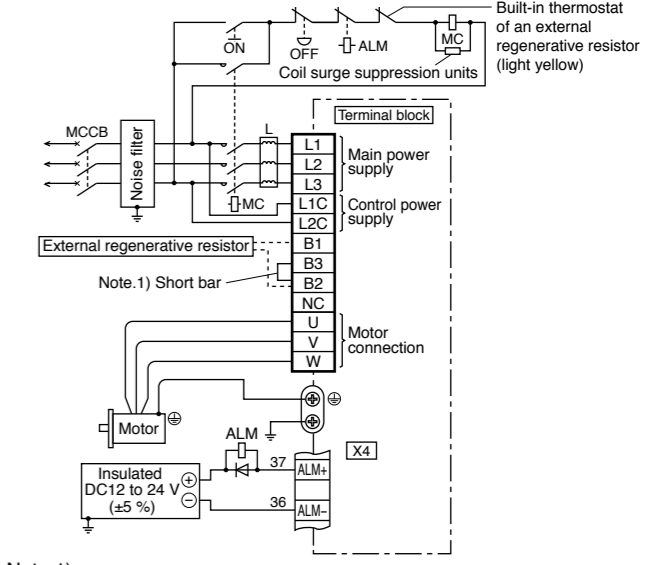

Note.1)

Frame No.	Short bar (Accessory)	Built-in regenerative resistor	Connection of terminal block	
			In case of using an external regenerative resistor.	In case of not using an external regenerative resistor.
F-frame	with	with	<ul style="list-style-type: none"> <li>Remove the short bar accessory from between B2-B3.</li> <li>Connect an external regenerative resistor between B1-B2</li> </ul>	<ul style="list-style-type: none"> <li>Shorted between B2-B3 with an attached short bar</li> </ul>

**In Case of 3-phase, H-frame, 200 V type**

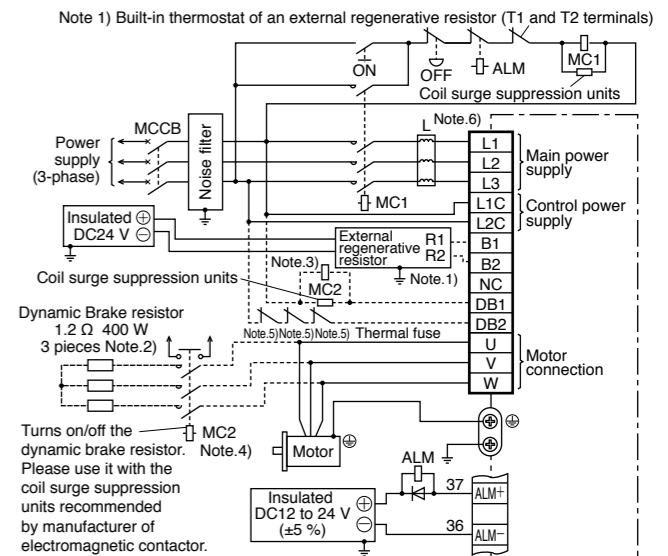

Note.1) About regenerative resistor

Frame No.	Short bar (Accessory)	Built-in regenerative resistor	Connection of terminal block	
			In case of using an external regenerative resistor.	In case of not using an external regenerative resistor.
H-frame	without	without	<ul style="list-style-type: none"> <li>(External regenerative resistor terminal)</li> <li>Terminal R1, R2 connect to B1, B2</li> <li>Terminal T1, T2 connect as shown above</li> <li>Terminal 24 V, 0 V connect to DC power supply of DC24 V.</li> <li>E terminal connect to the ground</li> </ul>	<ul style="list-style-type: none"> <li>Open between B1-B2</li> </ul>

Specification of external regenerative resistor, please refer to P.139, "Options Components".

Note.2) About dynamic brake resistor

Frame No.	Short bar (Accessory)	Built-in dynamic brake resistor.	Connection of terminal block	
			In case of using an external dynamic brake resistor.	In case of not using an external dynamic brake resistor.
H-frame	without	without	<ul style="list-style-type: none"> <li>Connect external dynamic brake resistor as shown above.</li> </ul>	<ul style="list-style-type: none"> <li>Open between DB1-DB2</li> </ul>

**In Case of 3-phase, D and E-frame, 400 V type**

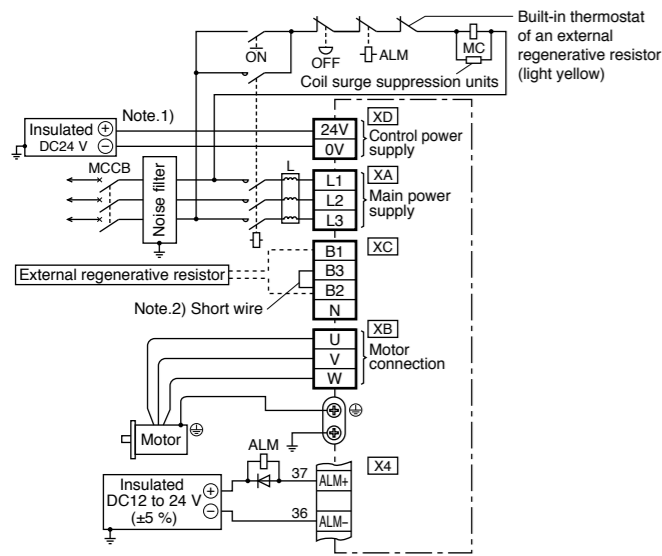

Note.1) Shielding the circuit is recommended for the purpose of noise reduction.  
Note.2)

Frame No.	Short wire (Accessory)	Built-in regenerative resistor	Connection of the connector XC	
			In case of using an external regenerative resistor.	In case of not using an external regenerative resistor.
E-frame	with	with	<ul style="list-style-type: none"> <li>Remove the short wire accessory from between B2-B3.</li> <li>Connect an external regenerative resistor between B1-B2.</li> </ul>	<ul style="list-style-type: none"> <li>Shorted between B2-B3 with an attached short wire</li> </ul>

**In Case of 3-phase, F-frame, 400 V type**

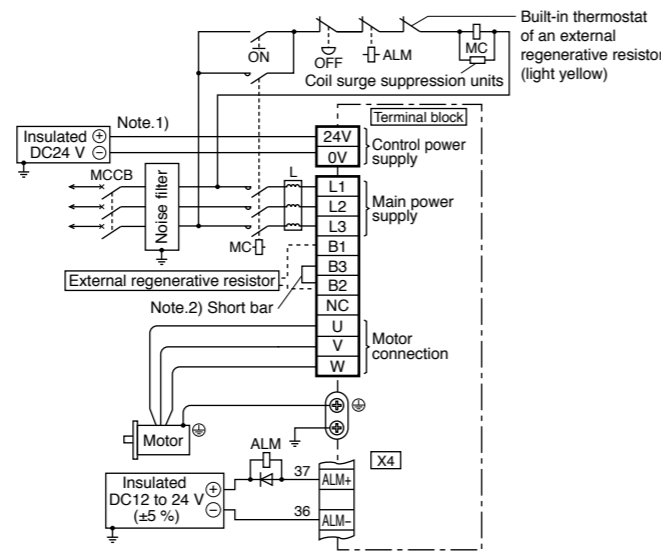

Note.1) Shielding the circuit is recommended for the purpose of noise reduction.  
Note.2)

Frame No.	Short bar (Accessory)	Built-in regenerative resistor	Connection of terminal block	
			In case of using an external regenerative resistor.	In case of not using an external regenerative resistor.
F-frame	with	with	<ul style="list-style-type: none"> <li>Remove the short bar accessory from between B2-B3.</li> <li>Connect an external regenerative resistor between B1-B2.</li> </ul>	<ul style="list-style-type: none"> <li>Shorted between B2-B3 with an attached short bar</li> </ul>

**In Case of 3-phase, G-frame, 400 V type**

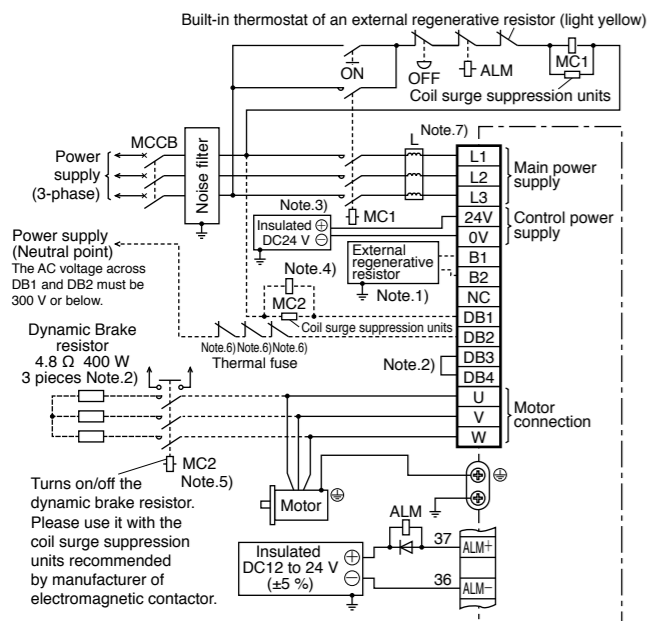

Note.1) About regenerative resistor

Frame No.	Short bar (Accessory)	Built-in regenerative resistor	Connection of terminal block	
			In case of using an external regenerative resistor.	In case of not using an external regenerative resistor.
G-frame	without	without	<ul style="list-style-type: none"> <li>Connect an external regenerative resistor between B1-B2.</li> </ul>	<ul style="list-style-type: none"> <li>Open between B1-B2</li> </ul>

Note.2) About dynamic brake resistor

Frame No.	Short bar (Accessory)	Built-in dynamic brake resistor.	Connection of terminal block	
			In case of using an external dynamic brake resistor.	In case of not using an external dynamic brake resistor.
G-frame	with	with	<ul style="list-style-type: none"> <li>Remove attached short bar between DB3-DB4.</li> <li>Connect external dynamic brake resistor as shown above.</li> </ul>	<ul style="list-style-type: none"> <li>Shorted with attached short bar between DB3-DB4.</li> <li>Open between DB1-DB2</li> </ul>

<common for G & H frame>

Note.3) Shielding the circuit is recommended for the purpose of noise reduction.

Note.4) Magnetic contactor MC2 must be the same rating as the contactor MC1 in the main circuit.

Note.5) Servo may be turned on in the external sequence if the contact deposits: to protect the system, provide the auxiliary contact.

Note.6) Provide an external protective device (e.g. thermal fuse) to monitor the temperature of the external dynamic brake resistor.

Note.7) Reactor should be prepared by the customer.

\* Refer to P.186, P.187, Specifications of Motor connector.

**In Case of 3-phase, H-frame, 400 V type**

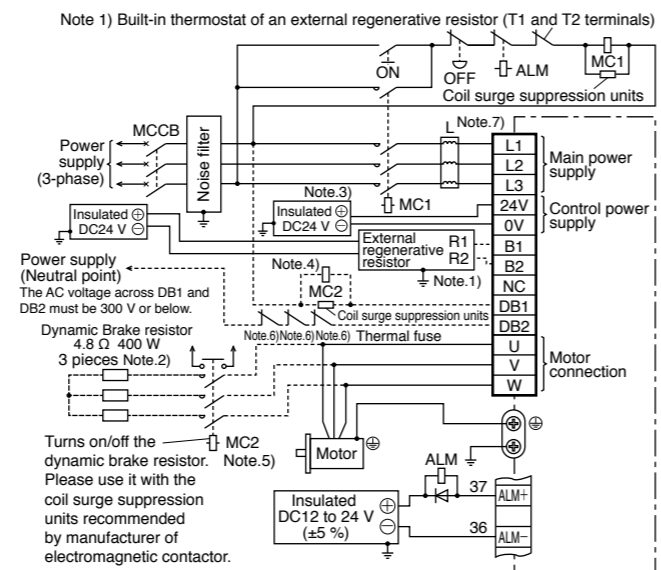

Note.1) About regenerative resistor

Frame No.	Short bar (Accessory)	Built-in regenerative resistor	Connection of terminal block	
			In case of using an external regenerative resistor.	In case of not using an external regenerative resistor.
H-frame	without	without	<ul style="list-style-type: none"> <li>(External regenerative resistor terminal)</li> <li>Terminal R1, R2 connect to B1, B2</li> <li>Terminal T1, T2 connection as shown above</li> <li>Terminal 24 V, 0 V connect to DC power supply of DC24 V.</li> <li>E terminal connect to the ground</li> </ul>	<ul style="list-style-type: none"> <li>Open between B1-B2</li> </ul>

Specification of external regenerative resistor, please refer to P.139, "Options Components".

Note.2) About dynamic brake resistor

Frame No.	Short bar (Accessory)	Built-in dynamic brake resistor.	Connection of terminal block	
			In case of using an external dynamic brake resistor.	In case of not using an external dynamic brake resistor.
H-frame	without	without	<ul style="list-style-type: none"> <li>Connect external dynamic brake resistor as shown above.</li> </ul>	<ul style="list-style-type: none"> <li>Open between DB1-DB2</li> </ul>

**Wiring to the Connector, X3 (Excluding A5IIE, A5E Series)**

Connecting the host controller can configure a safety circuit that controls the safety functions.  
When not constructing the safety circuit, use the supplied safety bypass plug.

**Outline Description of Safe Torque Off (STO)**

The safe torque off (STO) function is a safety function that shuts the motor current and turns off motor output torque by forcibly turning off the driving signal of the servo driver internal power transistor. For this purpose, the STO uses safety input signal and hardware (circuit).  
When STO function operates, the servo driver turns off the servo ready output signal (S-RDY) and enters safety state.  
This is an alarm condition and the 7-seg LED on the front panel displays the error code number.

**Safety Precautions**

- When using the STO function, be sure to perform equipment risk assessment to ensure that the system conforms to the safety requirements.
- Even while the STO function is working, the following potential safety hazards exist. Check safety in risk assessment.
  - The motor may move when external force (e.g. gravity force on vertical axis) is exerted on it. Provide an external brake, etc., as necessary to secure the motor. Note that the purpose of motor with brake is holding and it cannot be used for braking application.
  - When parameter Pr5.10 Sequence at alarm is set to free run (disable dynamic brake), the motor is free run state and requires longer stop distance even if no external force is applied. Make sure that this does not cause any problem.
  - When power transistor, etc., becomes defective, the motor will move to the extent equivalent of 180 electrical angle (max.). Make sure that this does not cause any problem.
  - The STO turns off the current to the motor but does not turn off power to the servo driver and does not isolate it. When starting maintenance service on the servo driver, turn off the driver by using a different disconnecting device.
- External device monitor (EDM) output signal is not a safety signal. Do not use it for an application other than failure monitoring.
- Dynamic brake and external brake release signal output are not related to safety function. When designing the system, make sure that the failure of external brake release during STO condition does not result in danger condition.
- When using STO function, connect equipment conforming to the safety standards.

[Connector pin assignment]  
(Viewed from cable)

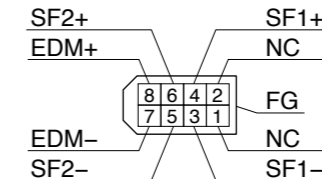

**System configuration**

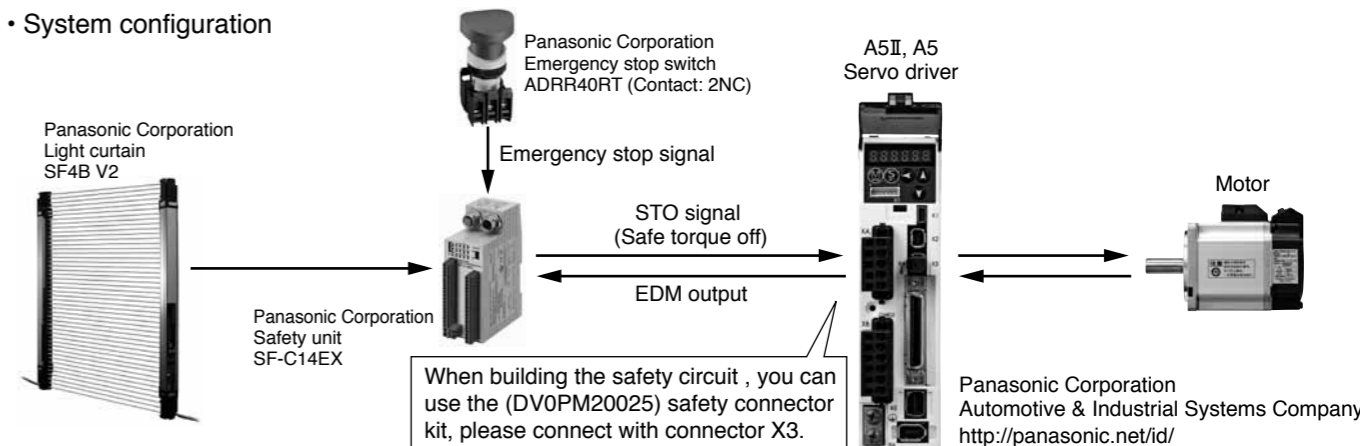

Wiring Example of Position Control Mode

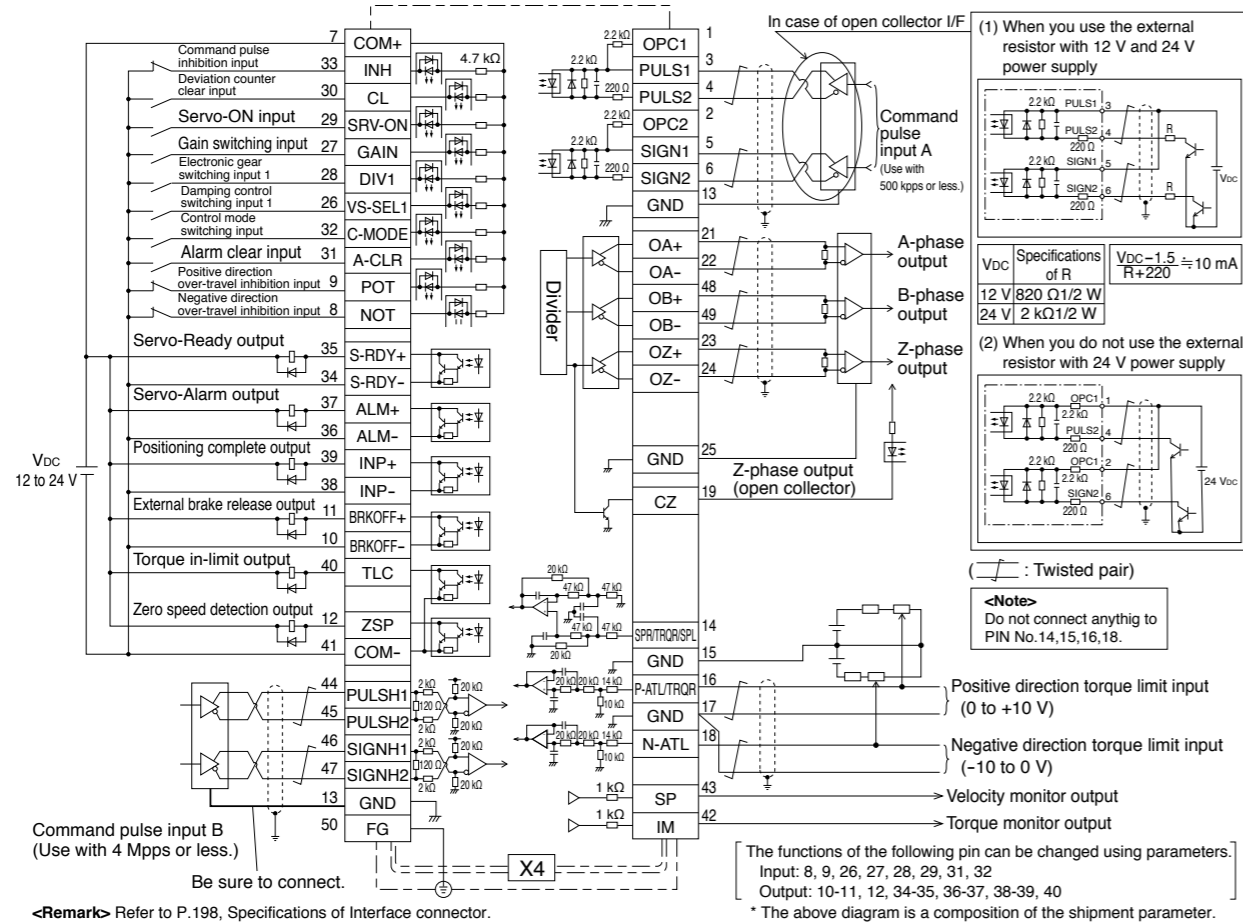

Wiring Example of Torque Control Mode (Excluding A5IE, A5E series)

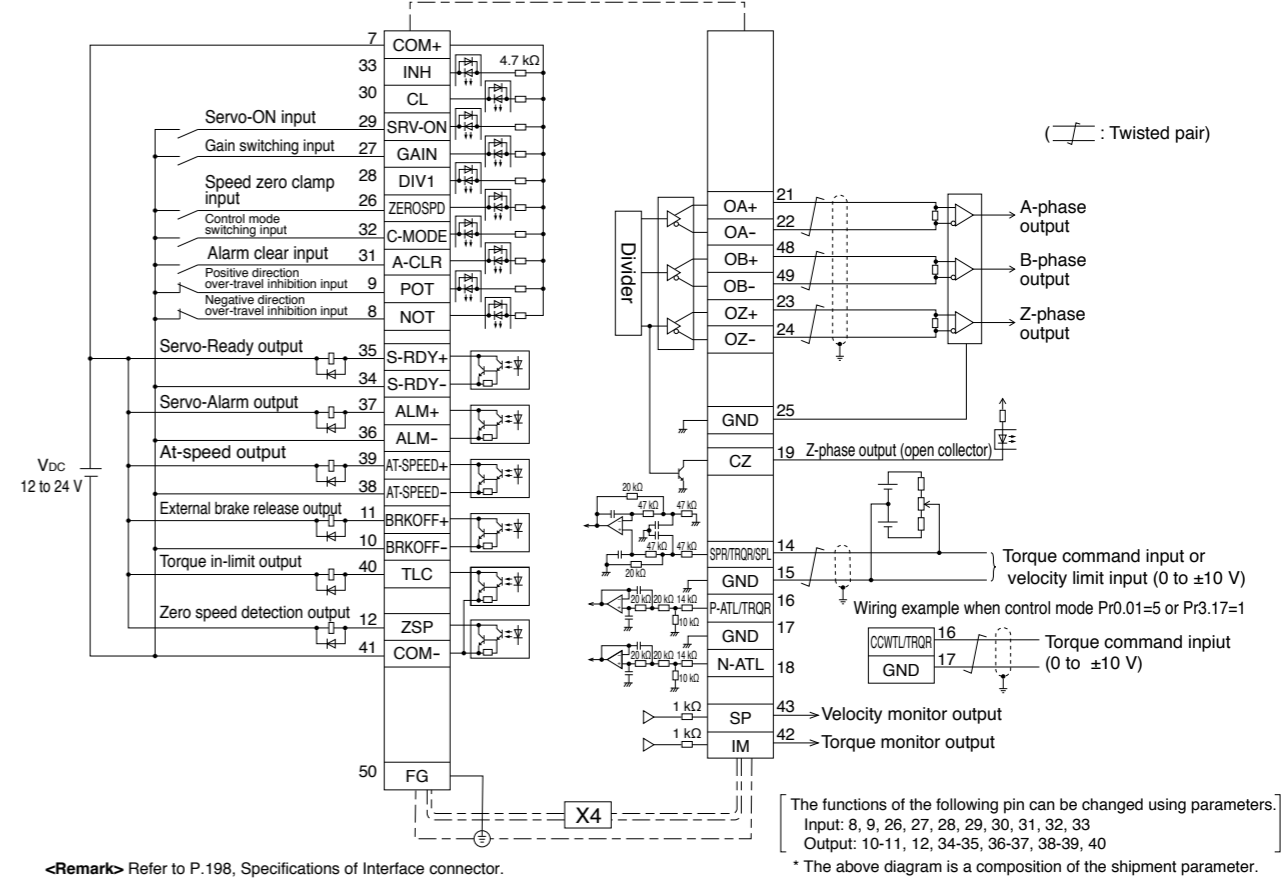

Wiring Example of Velocity Control Mode (Excluding A5IE, A5E series)

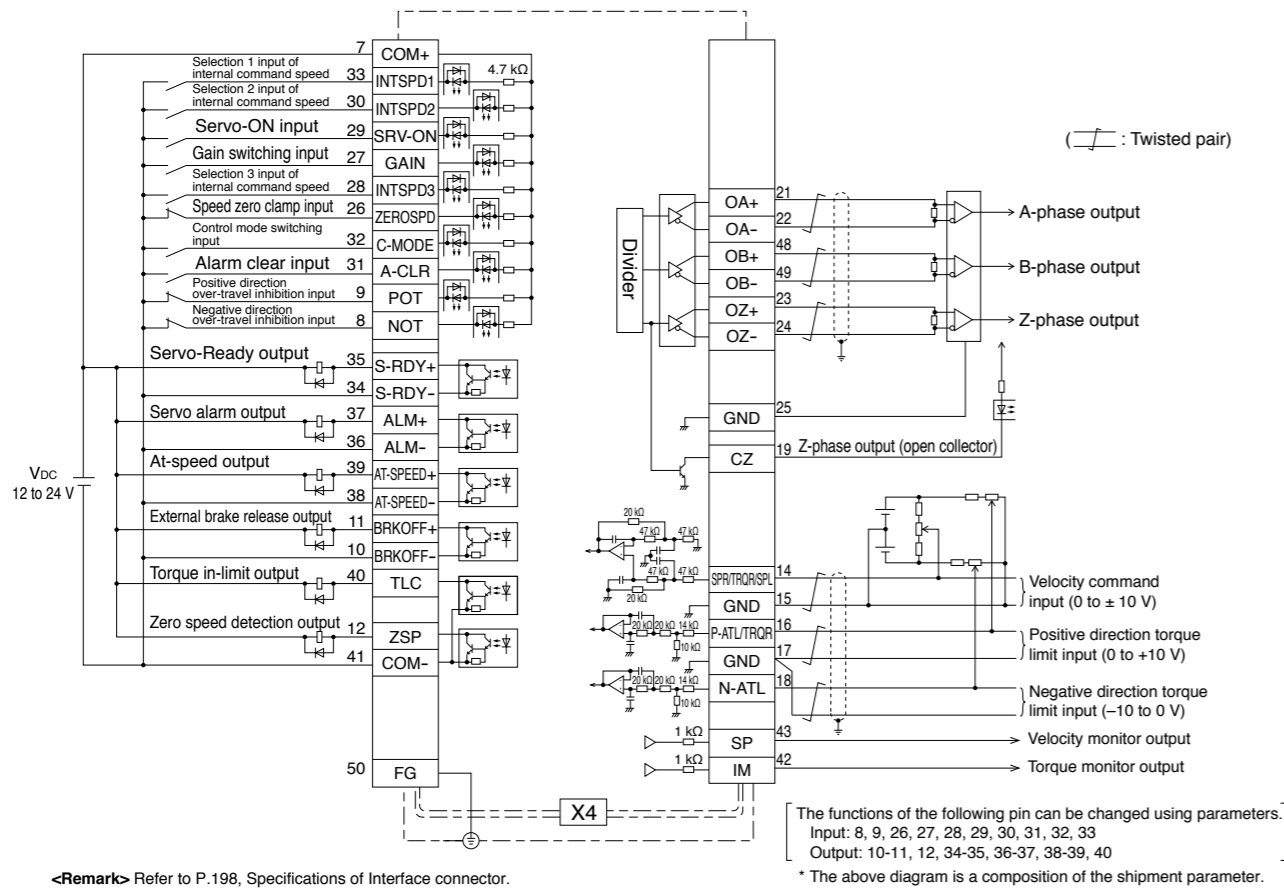

Wiring Example of Full-closed Control Mode (Excluding A5IE, A5E series)

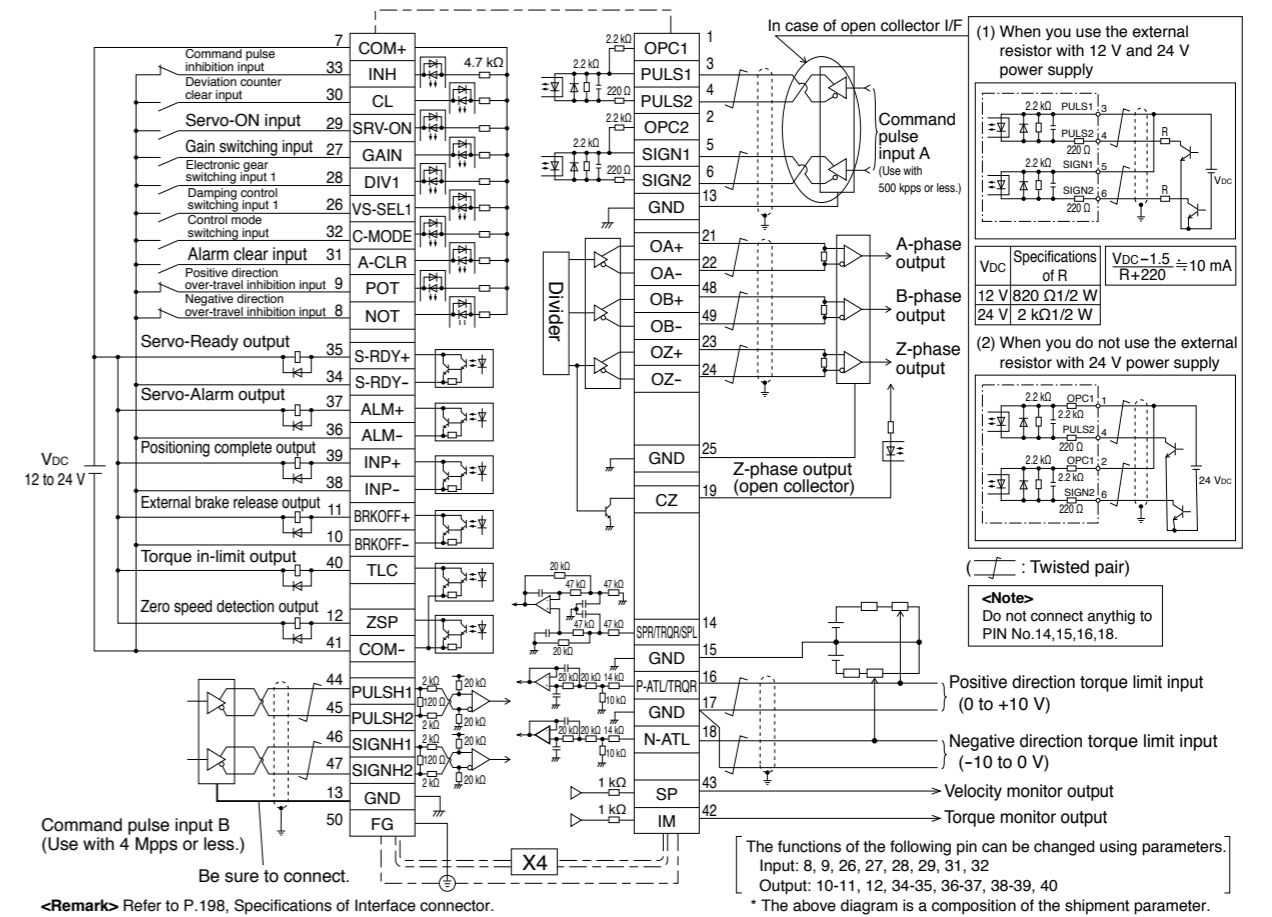

Applicable External Scale

The manufacturers applicable external scales for this product are as follows.

- Mitutoyo Corporation
- Magnescale Co., Ltd.
- MicroE systems
- Renishaw plc
- Fagor Automation S.Coop

\* For the details of the external scale product, contact each company.

Wiring Diagram of X5

<A/B-phase>

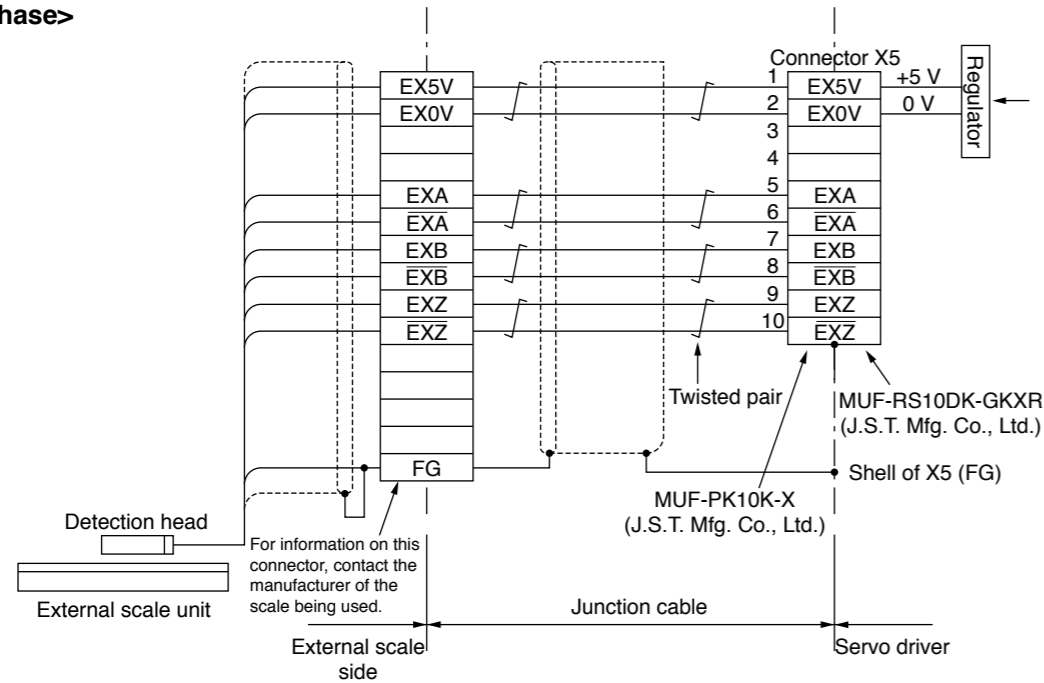

<Serial>

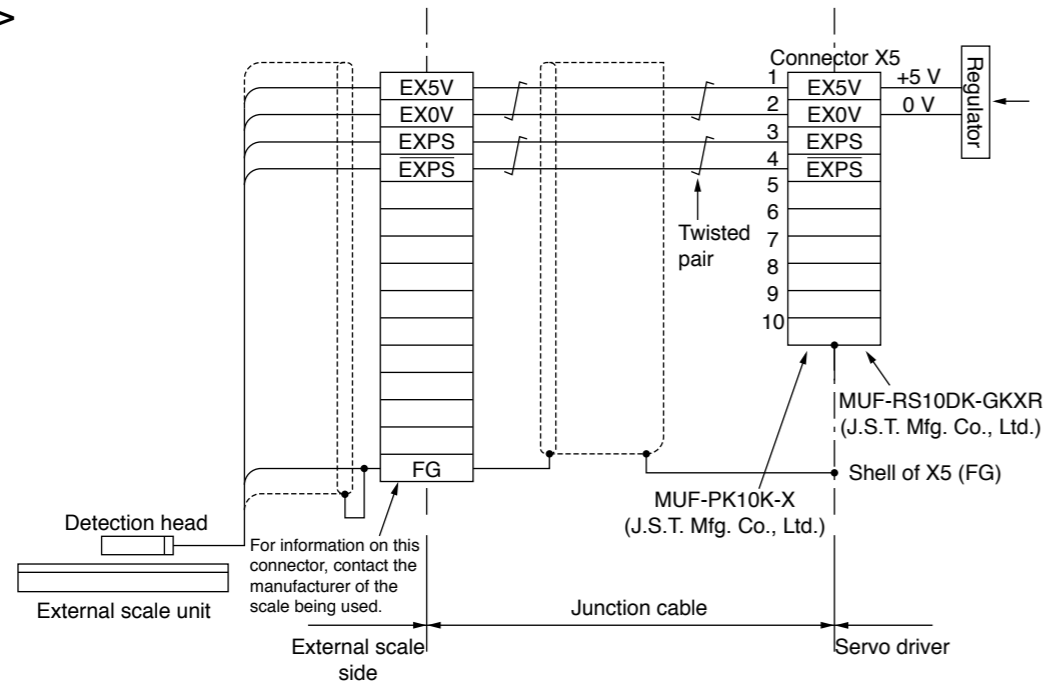

In Case of 20-bit Incremental Encoder

MSMD 50 W to 750 W, MHMD 200 W to 750 W

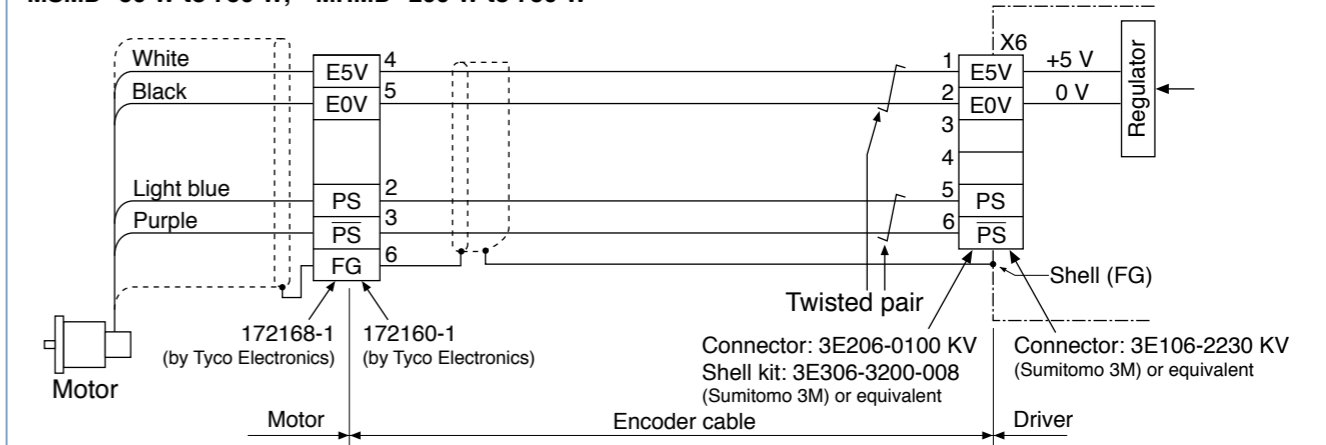

MSME 50 W to 750 W (200 V)

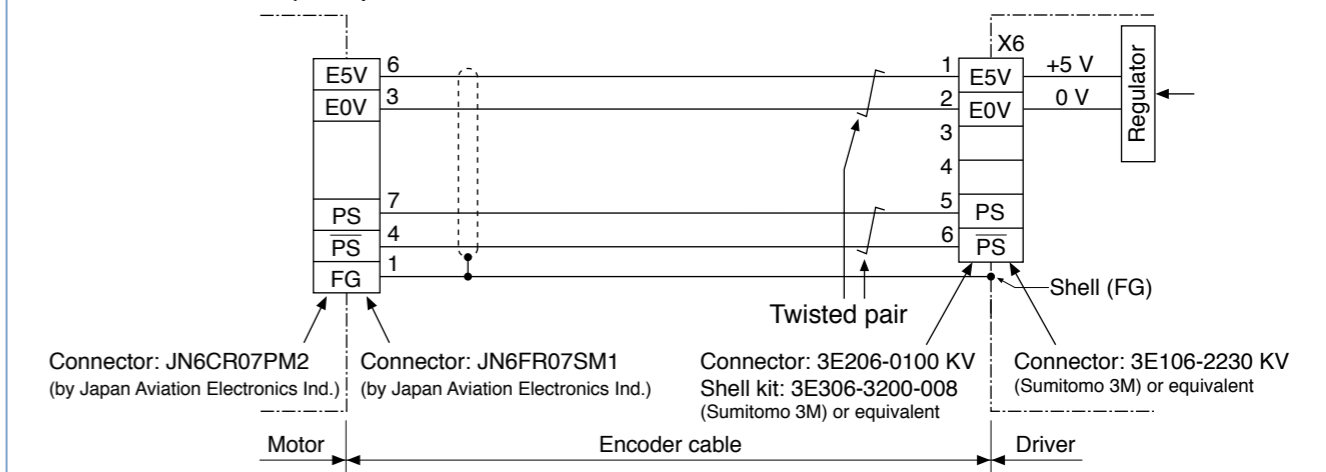

<Caution>

- Tighten the motor connector mounting screw (M2) with a torque between 0.19 and 0.21 N·m. To avoid damage, be sure to use only the screw supplied with the connector.
- Do not remove the gasket supplied with the junction cable connector. Securely install the gasket in place. Otherwise, the degree of protection of IP67 will not be guaranteed.

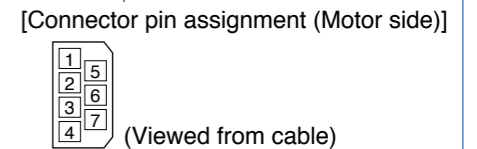

MSME 750 W (400 V), 1.0 kW to 5.0 kW, MDME 400 W to 15.0 kW, MFME 1.5 kW to 4.5 kW  
MGME 0.9 kW to 6.0 kW, MHME 1.0 kW to 7.5 kW

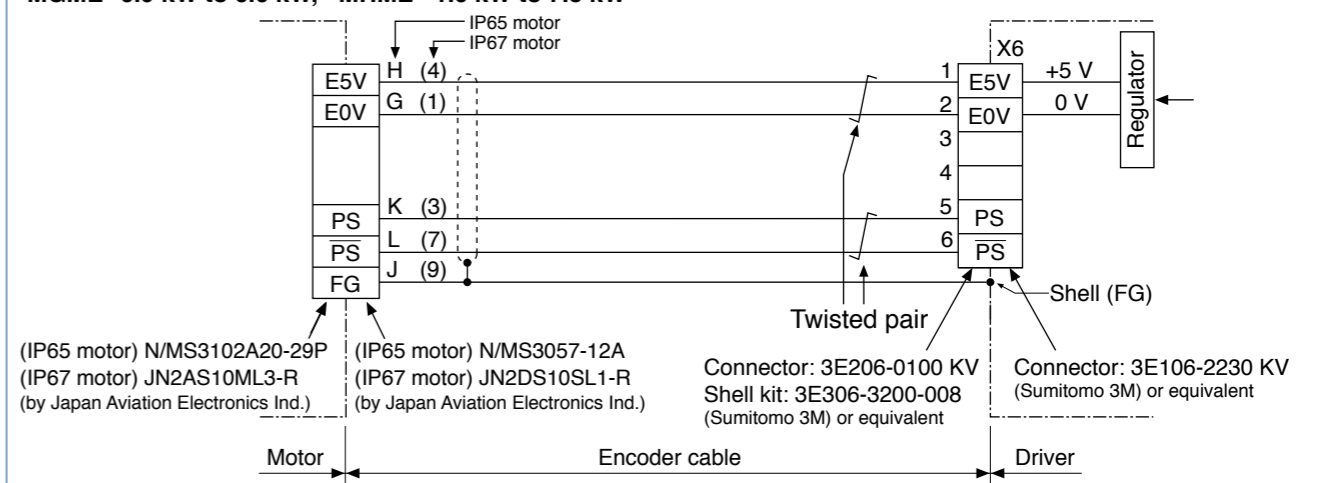

[Connector pin assignment] Refer to P.186, 187 "Specifications of Motor connector".

In Case of 17-bit Absolute Encoder (A5IE, A5E series does not correspond.)

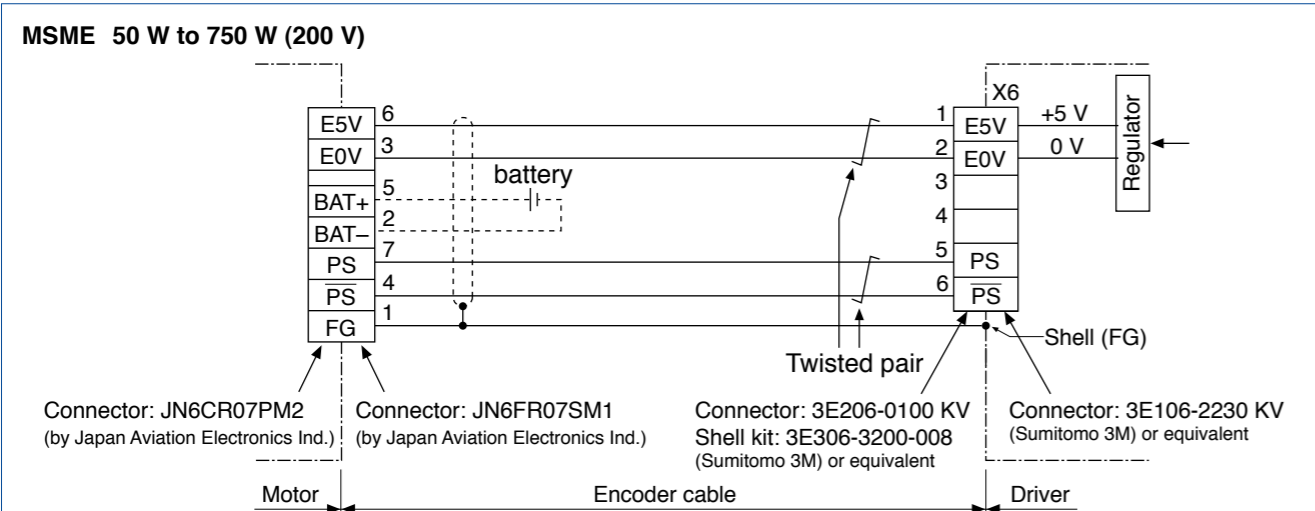
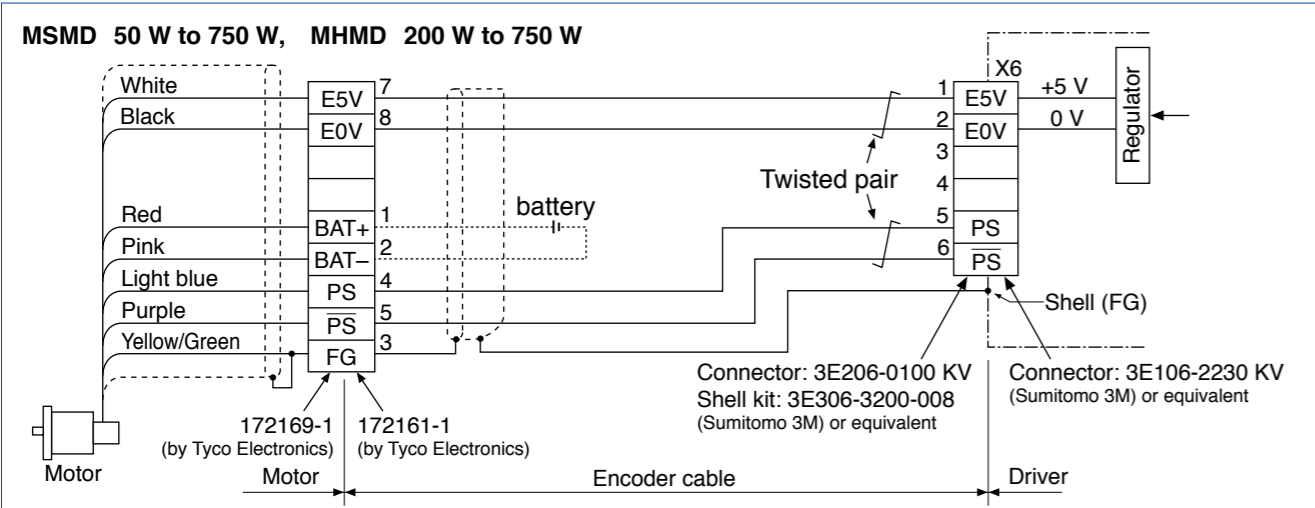

**<Caution>**

- Tighten the motor connector mounting screw (M2) with a torque between 0.19 and 0.21 N·m. To avoid damage, be sure to use only the screw supplied with the connector.
- Do not remove the gasket supplied with the junction cable connector. Securely install the gasket in place. Otherwise, the degree of protection of IP67 will not be guaranteed.

[Connector pin assignment (Motor side)]

(Viewed from cable)

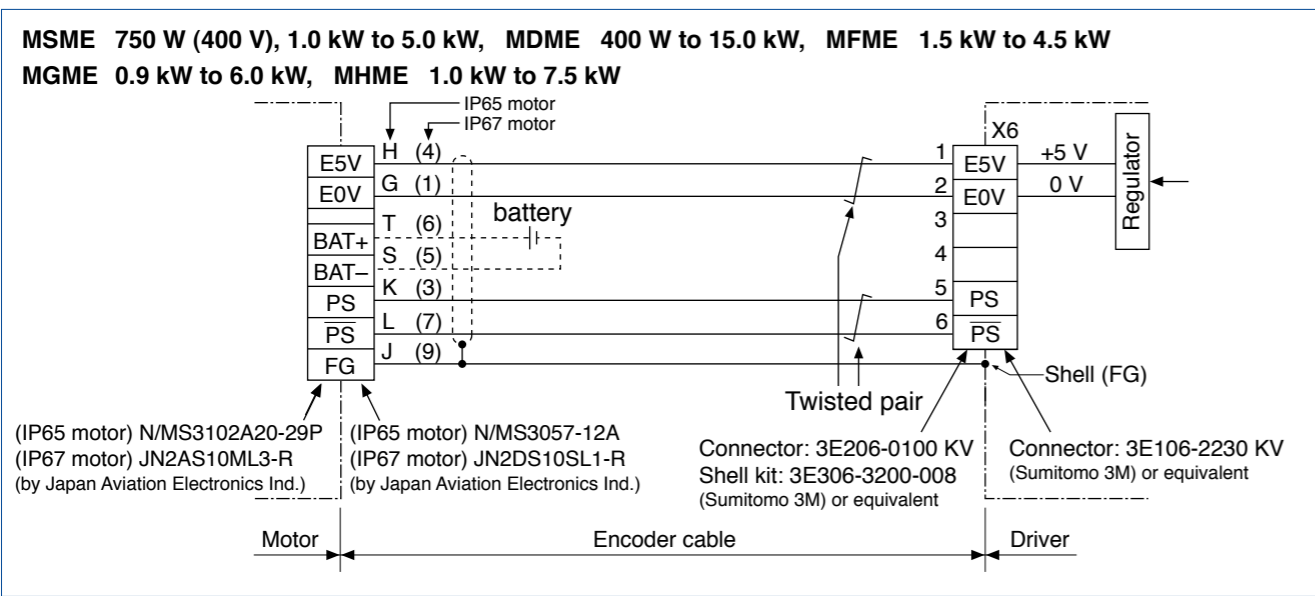

[Connector pin assignment] Refer to P.186, 187 "Specifications of Motor connector".

• The size of A5II, A5 series and A5IE, A5E series is same.

\*1 The height of the safety by-pass provided plug is one of the 14 mm or 24 mm to connector X3.

A-frame

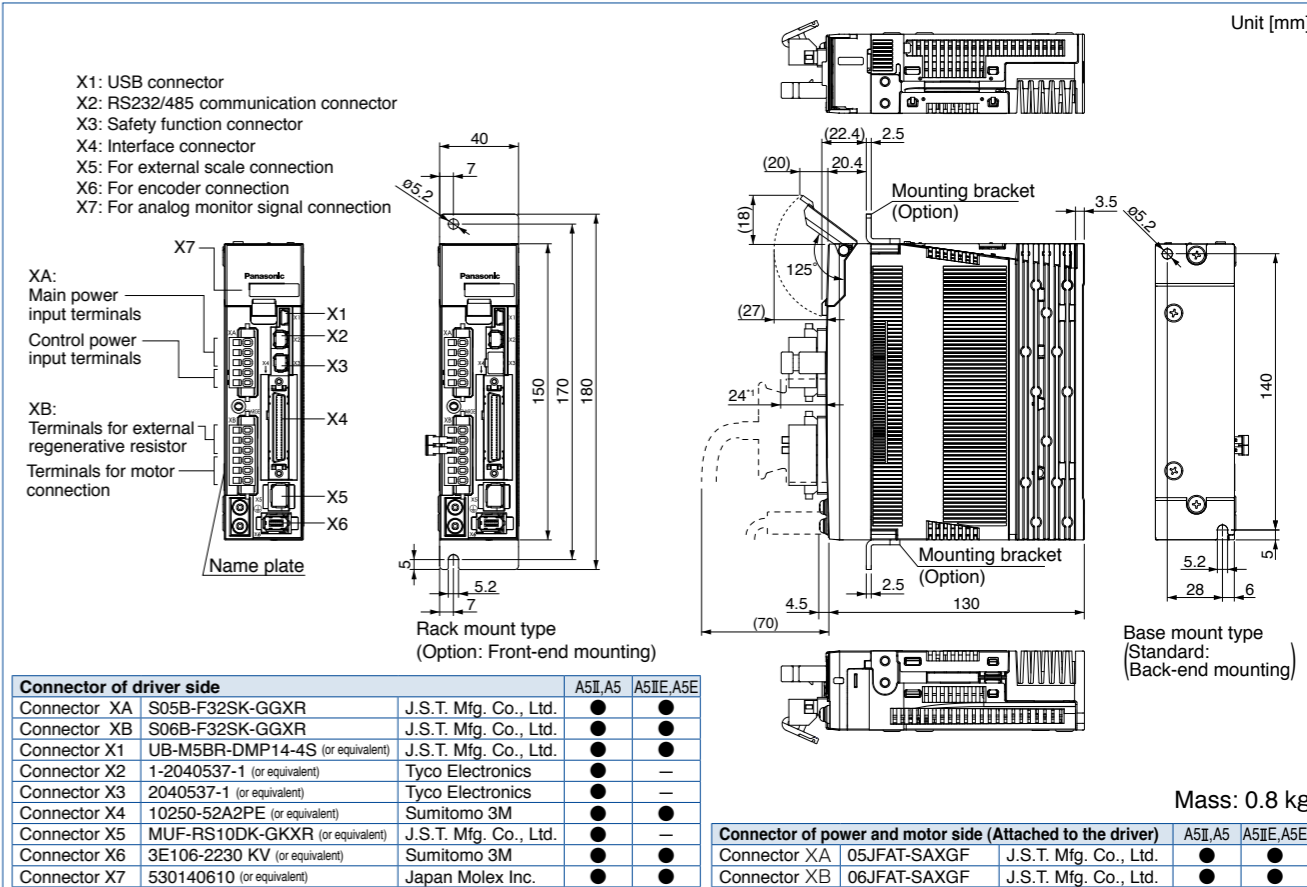

B-frame

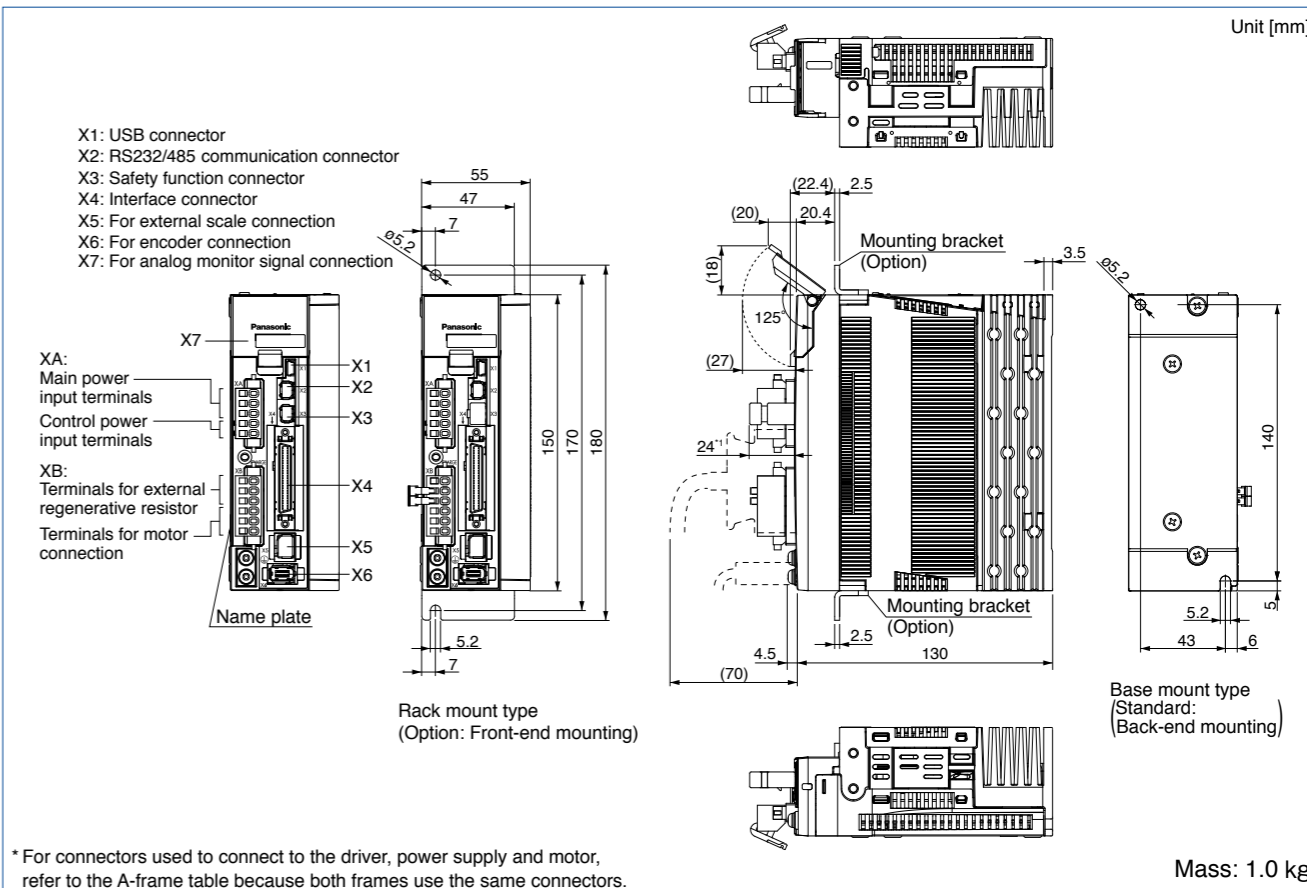

\* For connectors used to connect to the driver, power supply and motor, refer to the A-frame table because both frames use the same connectors.

• The size of A5II, A5 series and A5IE, A5E series is same.  
 \*1 The height of the safety by-pass provided plug is one of the 14 mm or 24 mm to connector X3.

C-frame

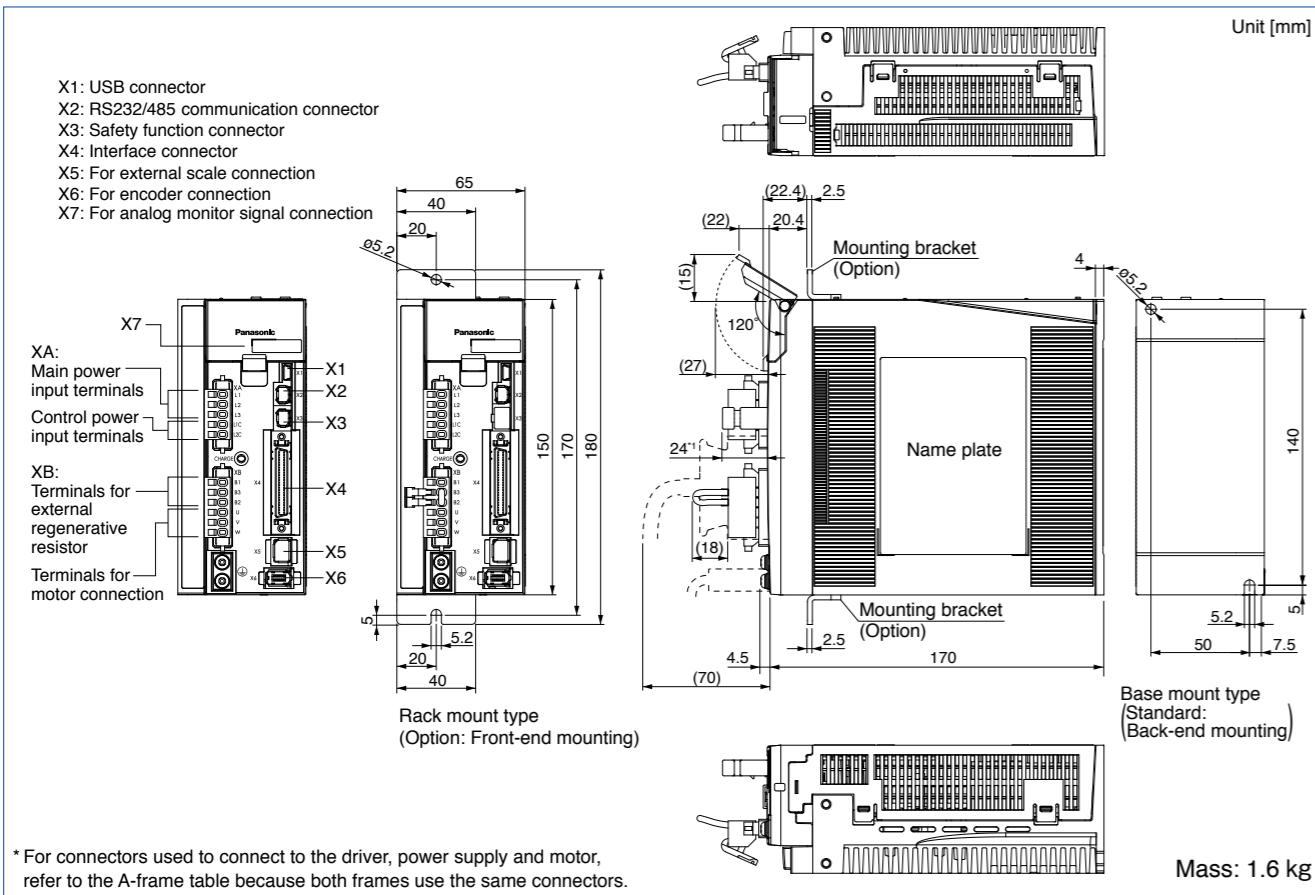

\* For connectors used to connect to the driver, power supply and motor, refer to the A-frame table because both frames use the same connectors.

D-frame (400 V)

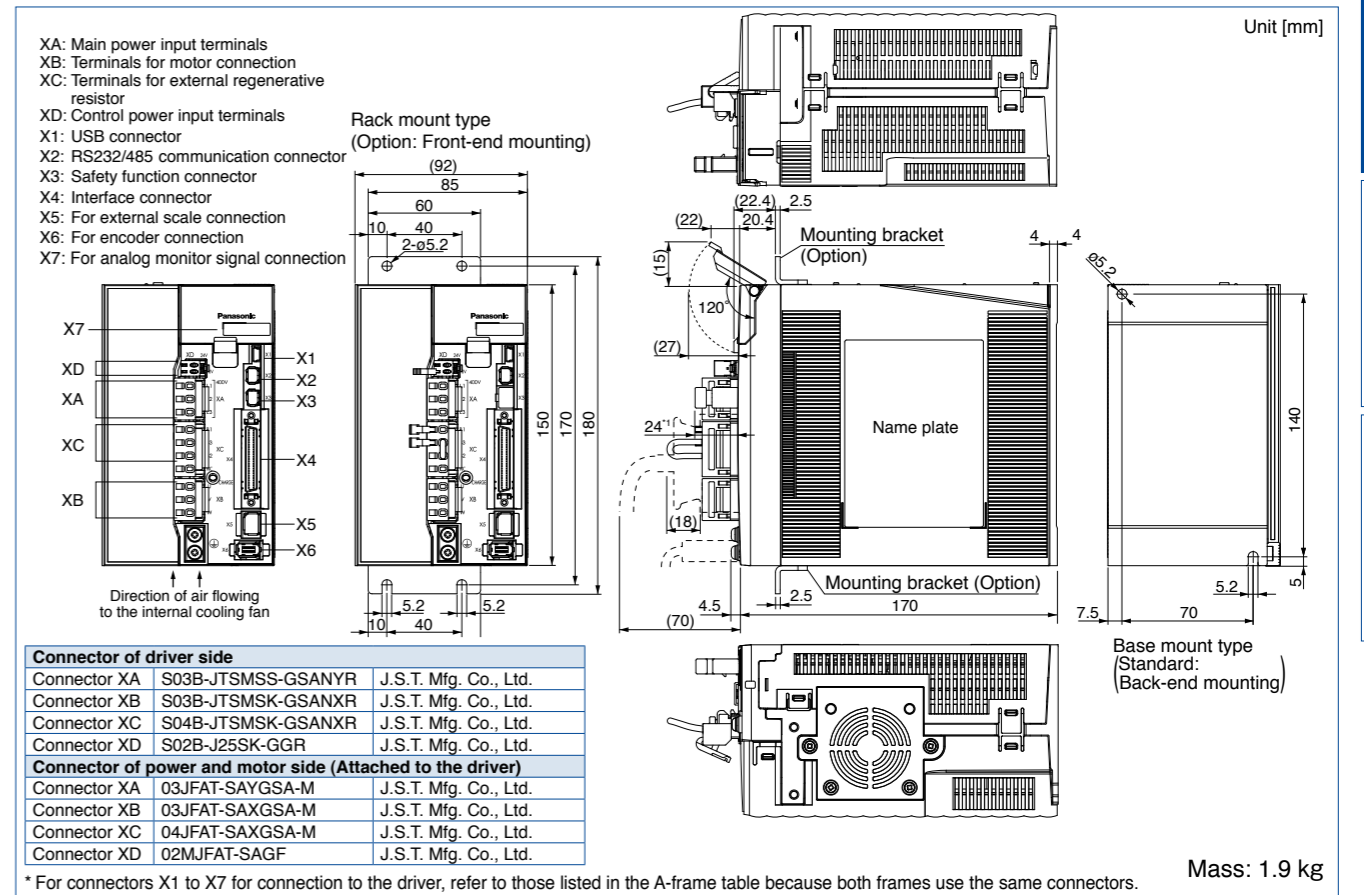

\* For connectors X1 to X7 for connection to the driver, refer to those listed in the A-frame table because both frames use the same connectors.

E-frame (200 V)

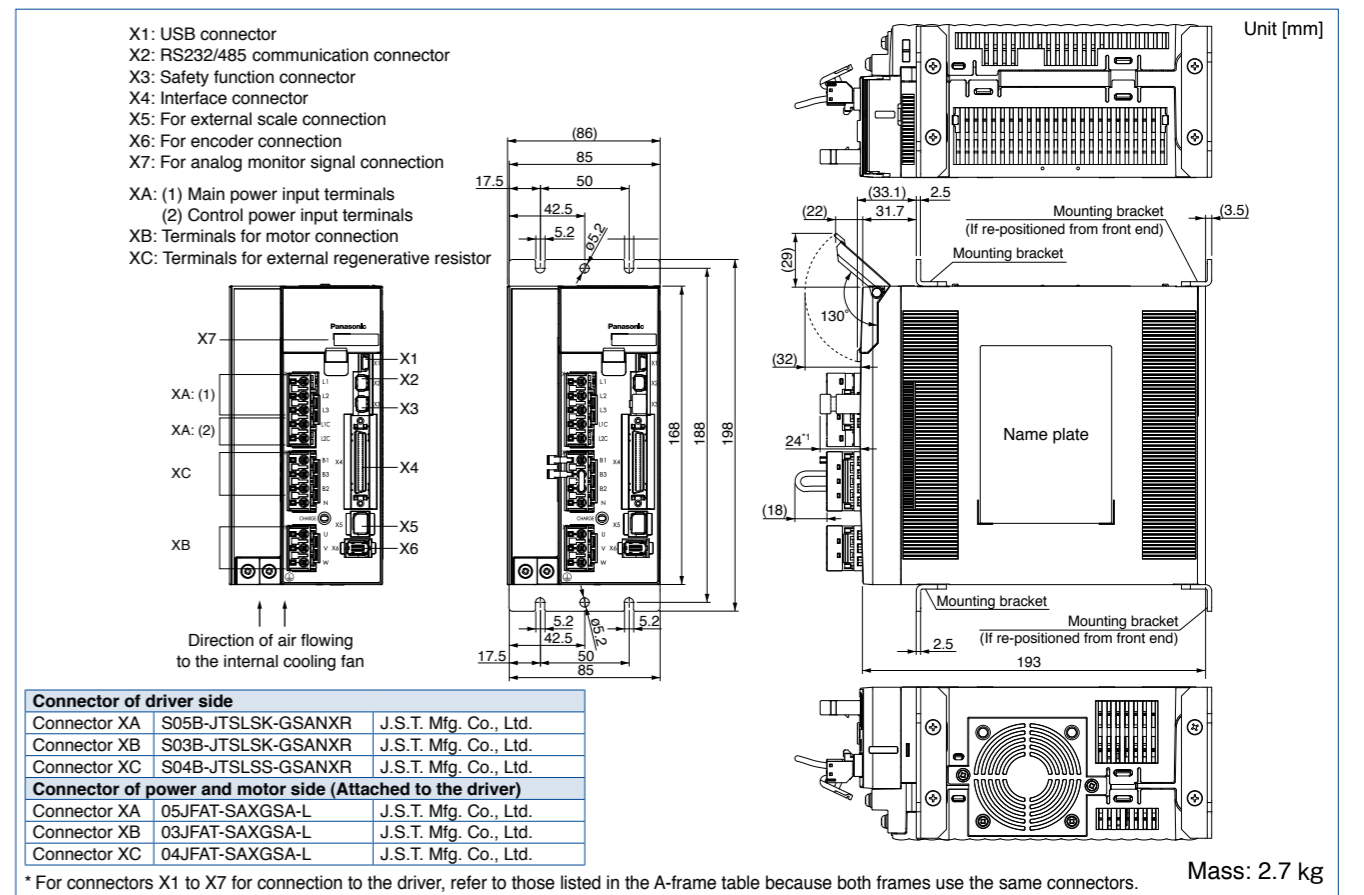

\* For connectors X1 to X7 for connection to the driver, refer to those listed in the A-frame table because both frames use the same connectors.

D-frame (200 V)

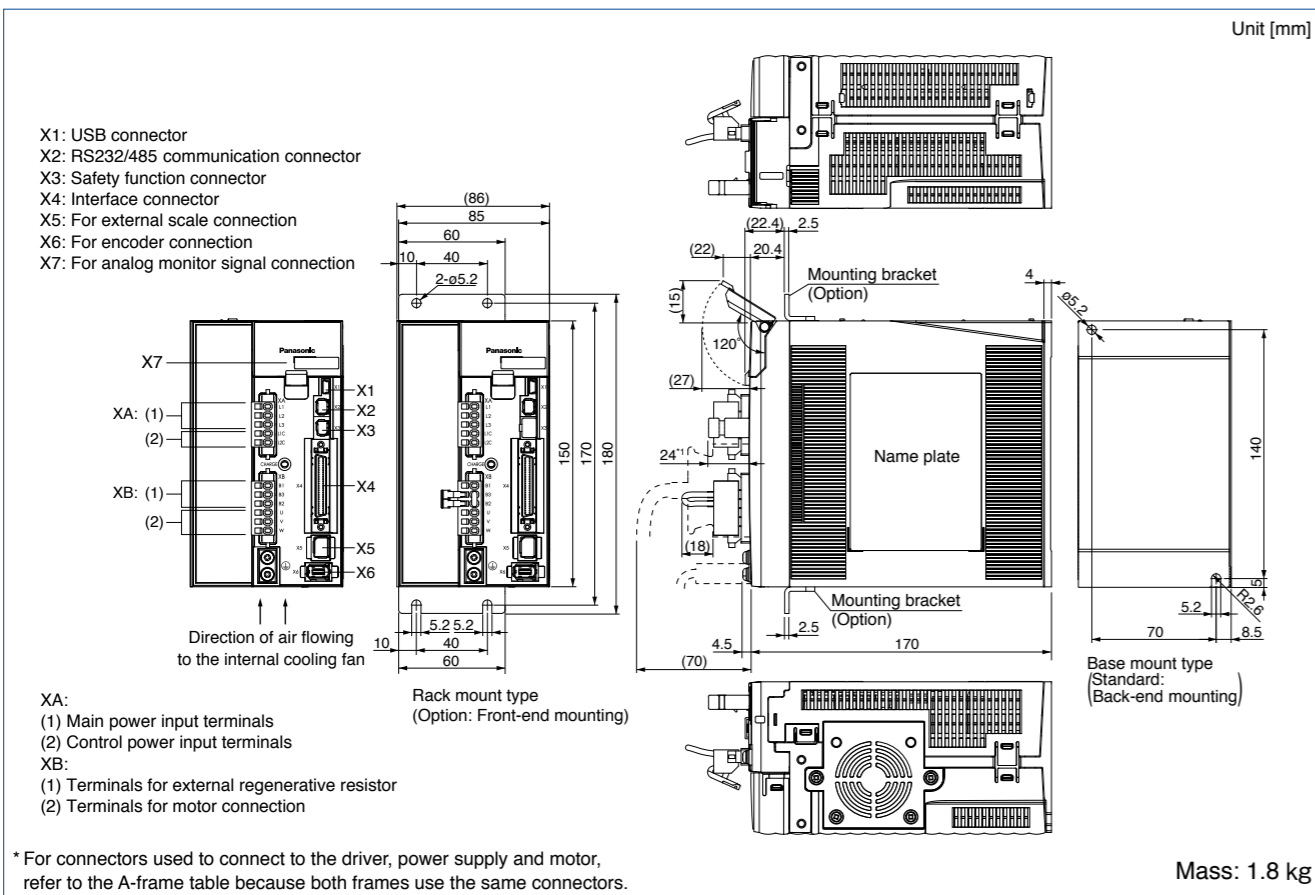

\* For connectors used to connect to the driver, power supply and motor, refer to the A-frame table because both frames use the same connectors.

● The size of A5II, A5 series and A5IE, A5E series is same.

\*1 The height of the safety by-pass provided plug is one of the 14 mm or 24 mm to connector X3.

**E-frame (400 V)**

- X1: USB connector
- X2: RS232/485 communication connector
- X3: Safety function connector
- X4: Interface connector
- X5: For external scale connection
- X6: For encoder connection
- X7: For analog monitor signal connection
- XA: Main power input terminals
- XB: Terminals for motor connection
- XC: Terminals for external regenerative resistor
- XD: Control power input terminals

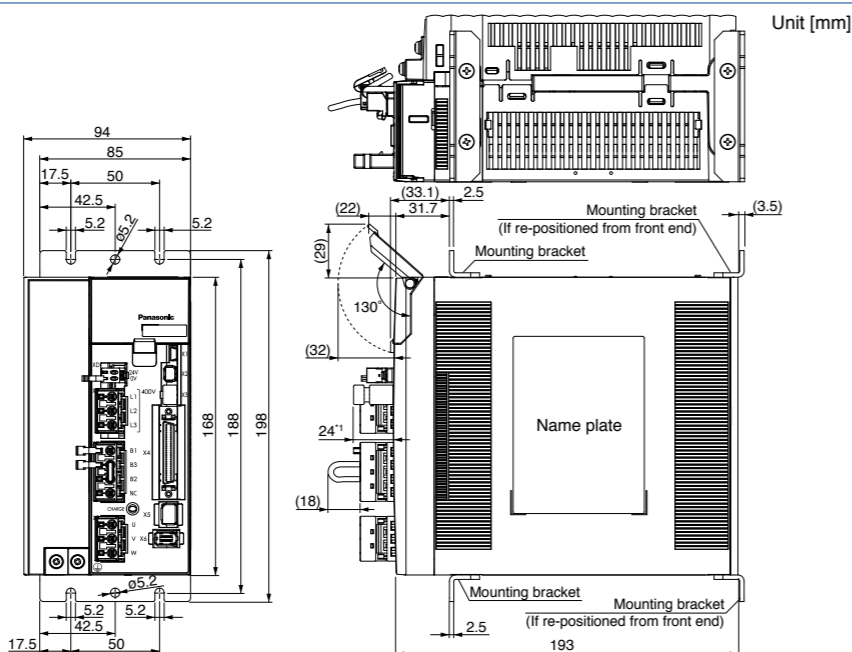
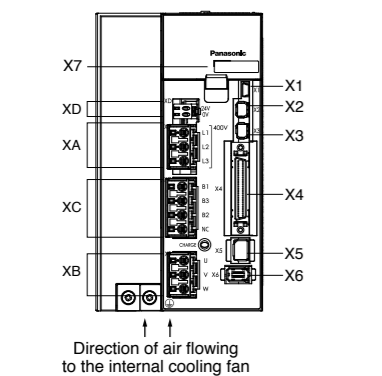

Connector of driver side		
Connector XA	S03B-JTSLSS-GSANYR	J.S.T. Mfg. Co., Ltd.
Connector XB	S03B-JTSLSK-GSANXR	J.S.T. Mfg. Co., Ltd.
Connector XC	S04B-JTSLSK-GSANXR	J.S.T. Mfg. Co., Ltd.
Connector XD	S02B-J25SK-GGR	J.S.T. Mfg. Co., Ltd.
Connector of power and motor side (Attached to the driver)		
Connector XA	03JFAT-SAYGSA-L	J.S.T. Mfg. Co., Ltd.
Connector XB	03JFAT-SAXGSA-L	J.S.T. Mfg. Co., Ltd.
Connector XC	04JFAT-SAXGSA-L	J.S.T. Mfg. Co., Ltd.
Connector XD	02MJFAT-SAGF	J.S.T. Mfg. Co., Ltd.

\* For connectors X1 to X7 for connection to the driver, refer to those listed in the A-frame table because both frames use the same connectors.

Mass: 2.7 kg

**F-frame (200 V/400 V)**

- X1: USB connector
- X2: RS232/485 communication connector
- X3: Safety function connector
- X4: Interface connector
- X5: For external scale connection
- X6: For encoder connection
- X7: For analog monitor signal connection

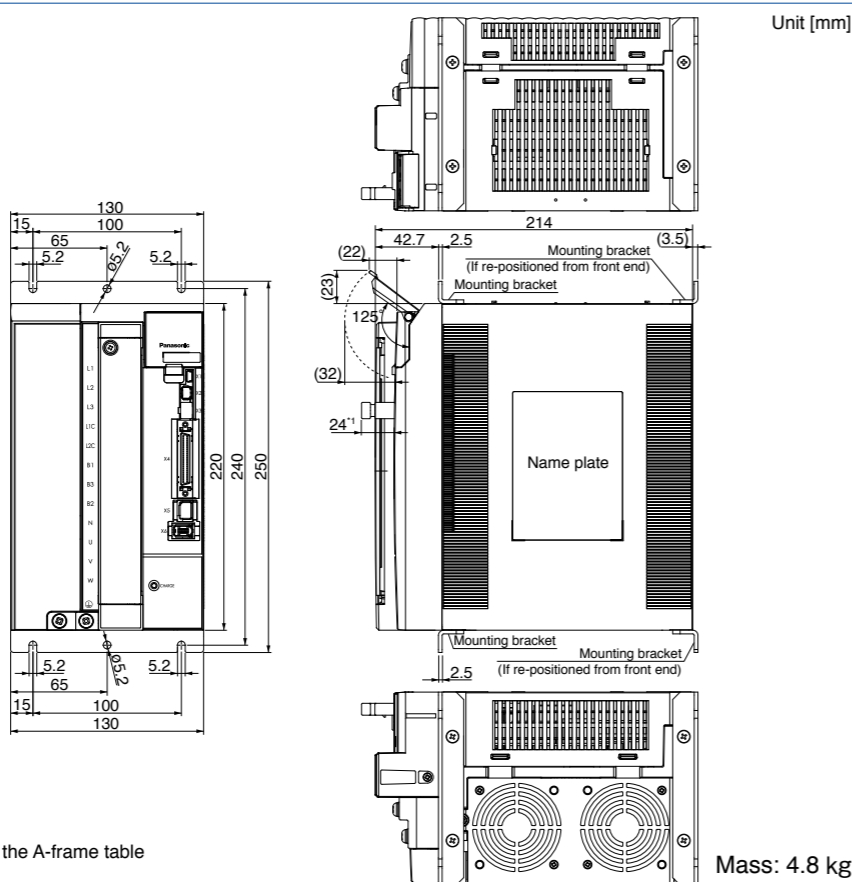
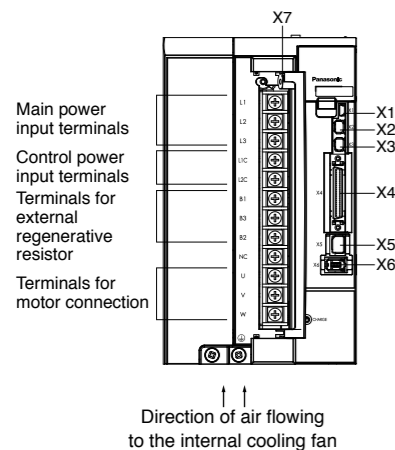

\* For connectors used to connect to the driver, refer to the A-frame table because both frames use the same connectors.

Mass: 4.8 kg

**G-frame (200 V/400 V) \* A5IE, A5E series is out of the lineup.**

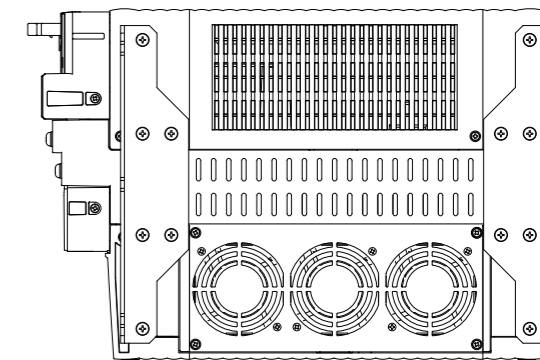
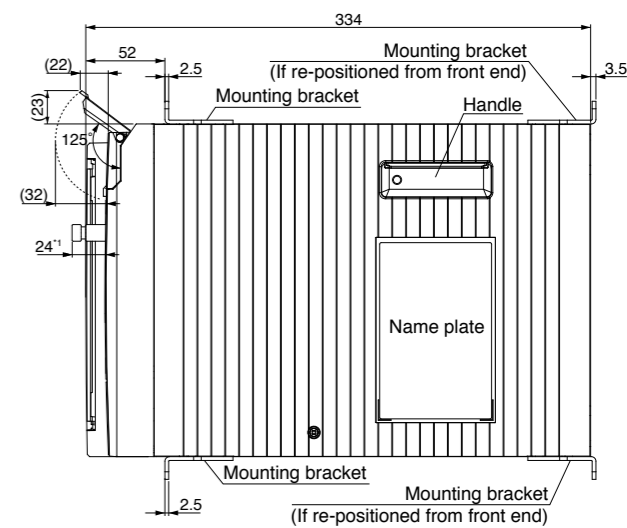
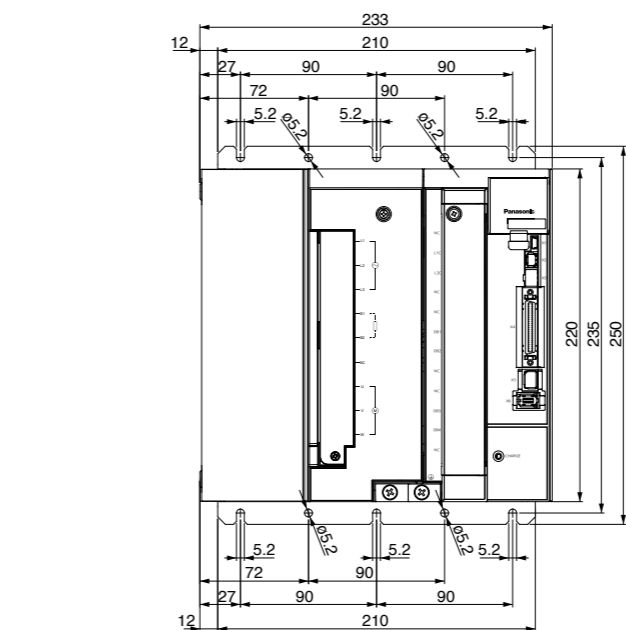
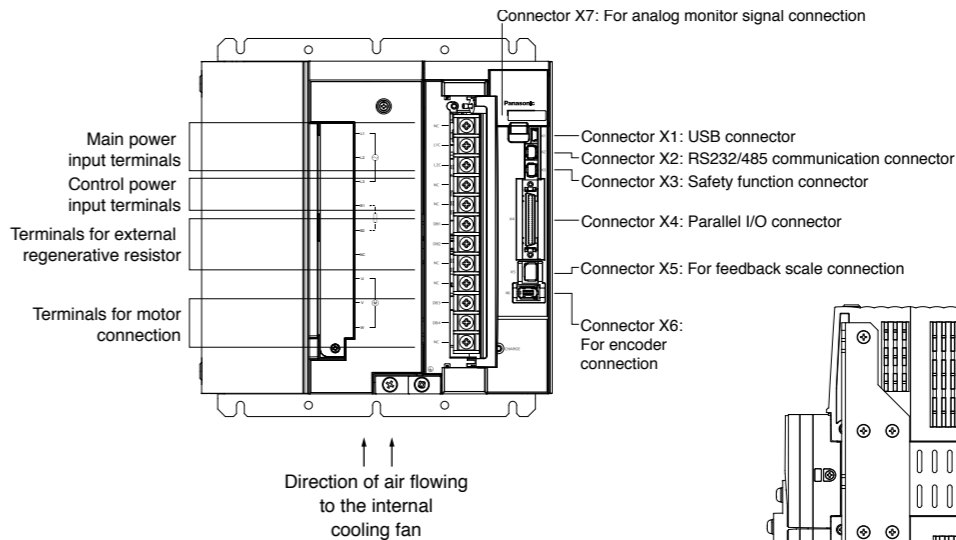

Unit [mm]

\* For connectors used to connect to the driver, refer to the A-frame table because both frames use the same connectors.

Mass: 13.5 kg



● A5IE, A5E series is out of the lineup.

\*1 The height of the safety by-pass provided plug is one of the 11 mm or 21 mm to connector X3.

H-frame (200 V/400 V)

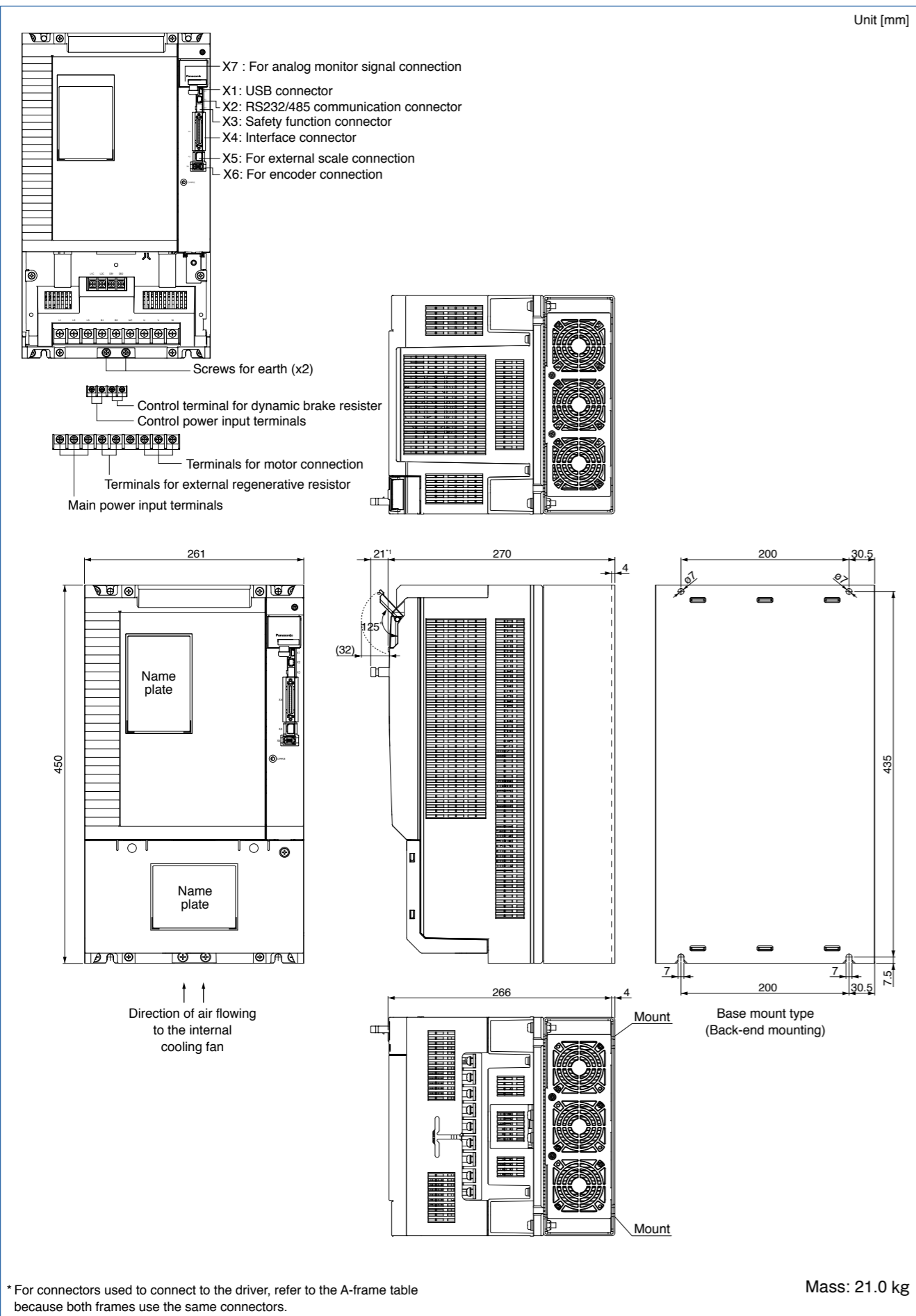

\* For connectors used to connect to the driver, refer to the A-frame table because both frames use the same connectors.

Motor Contents

**MSMD (100 V/200 V)**  
 50 W to 750 W ..... P.49

**MHMD (100 V/200 V)**  
 200 W to 750 W ..... P.59

**MSME (100 V/200 V)**  
 50 W to 750 W ..... P.65

**MSME (200 V)**  
 1.0 kW to 5.0 kW ..... P.74

**MDME (200 V)**  
 1.0 kW to 15.0 kW ..... P.80

**MFME (200 V)**  
 1.5 kW to 4.5 kW ..... P.89

**MGME (200 V)**  
 0.9 kW to 6.0 kW ..... P.92

**MHME (200 V)**  
 1.0 kW to 7.5 kW ..... P.97

**MSME (400 V)**  
 750 W to 5.0 kW ..... P.104

**MDME (400 V)**  
 400 W to 15.0 kW ..... P.111

**MFME (400 V)**  
 1.5 kW to 4.5 kW ..... P.122

**MGME (400 V)**  
 0.9 kW to 6.0 kW ..... P.125

**MHME (400 V)**  
 1.0 kW to 7.5 kW ..... P.130

**IP67 motor**  
 dimensions..... P.137

**Motors with Gear Reducer**  
 Type and Specifications..... P.141

Model No. designation ..... P.142

The combination of the driver and the motor..... P.142

Table of motor specifications... P.143

Torque Characteristics of Motor ..... P.144

Dimensions of Motor..... P.147

**Motor Specification Description**  
 Environmental Conditions.... P.182

Notes on [Motor specification] page..... P.182

Permissible Load at Output Shaft..... P.183









Built-in Holding Brake..... P.184

Features/ Lineup

Features

- Line-up IP65 motor: 50 W to 5.0 kW  
 IP67 motor: 50 W to 15.0 kW
- Max speed: 6000r/min (MSME 50 W to 750 W)
- Low inertia (MSME) to High inertia (MHME).
- Low cogging torque: Rated torque ratio 0.5 % (typical value).
- 20-bit incremental encoder (1,048,576 pulse)
- 17-bit absolute encoder (131,072 pulse).

Motor Lineup

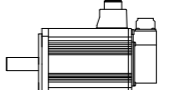
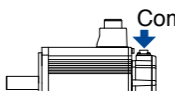
Small capacity	 <b>MSME</b> Low inertia Max. speed: 6000 r/min Rated speed: 3000 r/min Rated output: 50 W to 750 W(200 V) Enclosure: IP67	 <b>MSMD</b> Low inertia Max. speed: 5000 r/min : 4500 r/min(750 W) Rated speed: 3000 r/min Rated output: 50 W to 750 W Enclosure: IP65	 <b>MHMD</b> High inertia Max. speed: 5000 r/min : 4500 r/min(750 W) Rated speed: 3000 r/min Rated output: 200 W to 750 W Enclosure: IP65
	 <b>MSME</b> Low inertia Max. speed: 5000r /min : 4500 r/min (from 4.0 kW) Rated speed: 3000 r/min Rated output: 750 W(400 V), 1.0 kW to 5.0 kW Enclosure: IP65, IP67	 <b>MDME</b> Middle inertia Max. speed: 3000 r/min : 2000 r/min (from 11.0 kW) Rated speed: 2000 r/min : 1500 r/min (from 7.5 kW) Rated output IP65: 400 W to 5.0 kW IP67: 400 W to 15.0 kW Enclosure: IP65, IP67	 <b>MFME</b> (Flat type)* Middle inertia Max. speed: 3000 r/min Rated speed: 2000 r/min Rated output: 1.5 kW to 4.5 kW Enclosure: IP67
Middle capacity	 <b>MGME</b> (Low speed/ High torque type) Middle inertia Max. speed: 2000 r/min Rated speed: 1000 r/min Rated output IP65: 0.9 kW to 3.0 kW IP67: 0.9 kW to 6.0 kW Enclosure: IP65, IP67	 <b>MHME</b> High inertia Max. speed: 3000 r/min Rated speed: 2000 r/min : 1500 r/min(7.5 kW) Rated output IP65: 1.0 kW to 5.0 kW IP67: 1.0 kW to 7.5 kW Enclosure: IP65, IP67	Middle capacity motor has the IP67 type.  (IP65 type motor)  Compact (IP67 type motor) Part No.: M□ME****□* C: IP65 motor 1: IP67 motor

Specifications

		AC100 V	
Motor model *1	IP65	MSMD5AZG1□	MSMD5AZS1□
	IP67	-	-
Applicable driver *2	Model No. A5II, A5 series	MAD◇T1105	
	Model No. A5IE, A5E series	MAD◇T1105E	-
Frame symbol		A-frame	
Power supply capacity (kVA)		0.5	
Rated output (W)		50	
Rated torque (N·m)		0.16	
Momentary Max. peak torque (N·m)		0.48	
Rated current (A(rms))		1.1	
Max. current (A(o-p))		4.7	
Regenerative brake frequency (times/min) Note1	Without option	No limit Note2	
	DV0P4280	No limit Note2	
Rated rotational speed (r/min)		3000	
Max. rotational speed (r/min)		5000	
Moment of inertia of rotor (×10 <sup>-4</sup> kg·m <sup>2</sup> )	Without brake	0.025	
	With brake	0.027	
Recommended moment of inertia ratio of the load and the rotor Note3		30 times or less	
Rotary encoder specifications Note5	20-bit Incremental		17-bit Absolute
	Resolution per single turn	1,048,576	131,072

• **Brake specifications** (For details, refer to P.183)  
 (This brake will be released when it is energized.)  
 (Do not use this for braking the motor in motion.)

Static friction torque (N·m)	0.29 or more
Engaging time (ms)	35 or less
Releasing time (ms) Note4	20 or less
Exciting current (DC) (A)	0.3
Releasing voltage (DC) (V)	1 or more
Exciting voltage (DC) (V)	24±1.2

• **Permissible load** (For details, refer to P.183)

During assembly	Radial load P-direction (N)	147
	Thrust load A-direction (N)	88
	Thrust load B-direction (N)	117.6
During operation	Radial load P-direction (N)	68.6
	Thrust load A, B-direction (N)	58.8

• For details of Note 1 to Note 5, refer to P.182, 183.

• Dimensions of Driver, refer to P.42.

\*1 Motor specifications: □

\*2 The product that the end of driver model designation has "E" is "Position control type". Detail of model designation, refer to P.16.

\*3 ◇ in number of applicable driver represents the series. For more information about the part number, please refer to P.16.

Torque characteristics (at AC100 V of power voltage <Dotted line represents the torque at 10% less supply voltage.>)

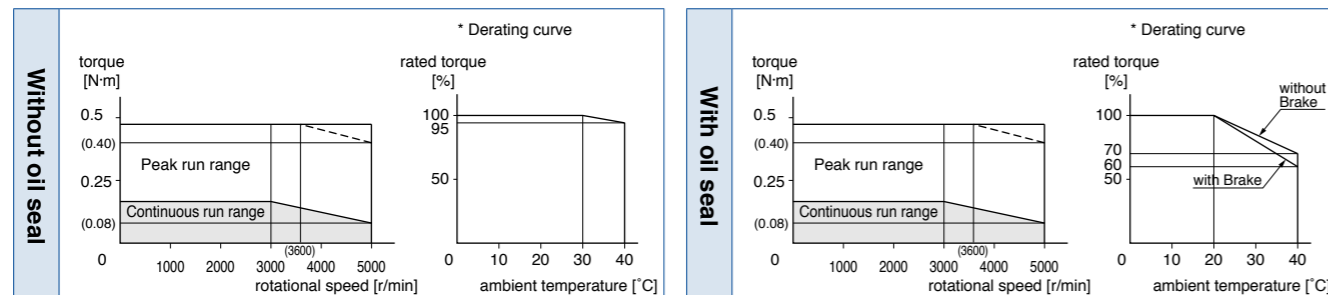

Dimensions

<Without Brake>

Mass: 0.32 kg

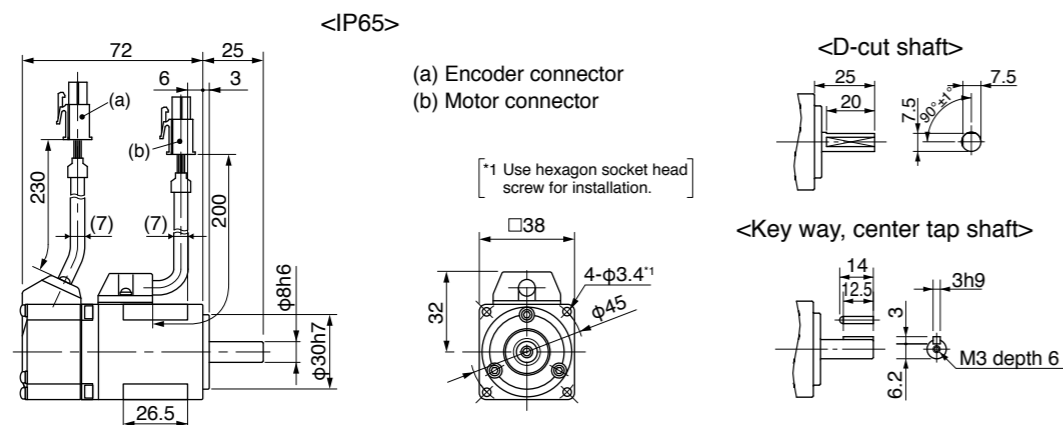

\* For the dimensions with brake, refer to the right page.

[Unit: mm]

<Cautions> Reduce the moment of inertia ratio if high speed response operation is required. Dimensions are subject to change without notice. Contact us or a dealer for the latest information. Read the Instruction Manual carefully and understand all precautions and remarks before using the products.

Specifications

		AC200 V	
Motor model *1	IP65	MSMD5AZG1□	MSMD5AZS1□
	IP67	-	-
Applicable driver *2	Model No. A5II, A5 series	MAD◇T1505	
	Model No. A5IE, A5E series	MAD◇T1505E	-
Frame symbol		A-frame	
Power supply capacity (kVA)		0.5	
Rated output (W)		50	
Rated torque (N·m)		0.16	
Momentary Max. peak torque (N·m)		0.48	
Rated current (A(rms))		1.1	
Max. current (A(o-p))		4.7	
Regenerative brake frequency (times/min) Note1	Without option	No limit Note2	
	DV0P4281	No limit Note2	
Rated rotational speed (r/min)		3000	
Max. rotational speed (r/min)		5000	
Moment of inertia of rotor (×10 <sup>-4</sup> kg·m <sup>2</sup> )	Without brake	0.025	
	With brake	0.027	
Recommended moment of inertia ratio of the load and the rotor Note3		30 times or less	
Rotary encoder specifications Note5	20-bit Incremental		17-bit Absolute
	Resolution per single turn	1,048,576	131,072

• **Brake specifications** (For details, refer to P.183)  
 (This brake will be released when it is energized.)  
 (Do not use this for braking the motor in motion.)

Static friction torque (N·m)	0.29 or more
Engaging time (ms)	35 or less
Releasing time (ms) Note4	20 or less
Exciting current (DC) (A)	0.3
Releasing voltage (DC) (V)	1 or more
Exciting voltage (DC) (V)	24±1.2

• **Permissible load** (For details, refer to P.183)

During assembly	Radial load P-direction (N)	147
	Thrust load A-direction (N)	88
	Thrust load B-direction (N)	117.6
During operation	Radial load P-direction (N)	68.6
	Thrust load A, B-direction (N)	58.8

• For details of Note 1 to Note 5, refer to P.182, 183.

• Dimensions of Driver, refer to P.42.

\*1 Motor specifications: □

\*2 The product that the end of driver model designation has "E" is "Position control type". Detail of model designation, refer to P.16.

\*3 ◇ in number of applicable driver represents the series. For more information about the part number, please refer to P.16.

Torque characteristics (at AC200 V of power voltage <Dotted line represents the torque at 10% less supply voltage.>)

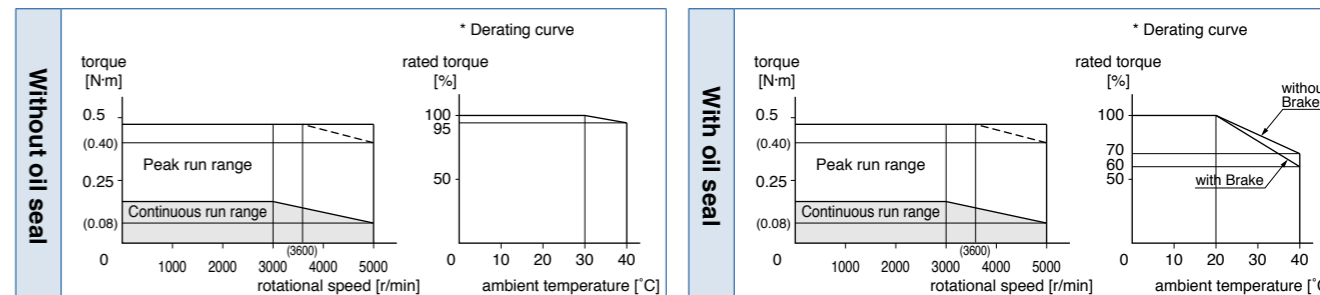

Dimensions

<With Brake>

Mass: 0.53 kg

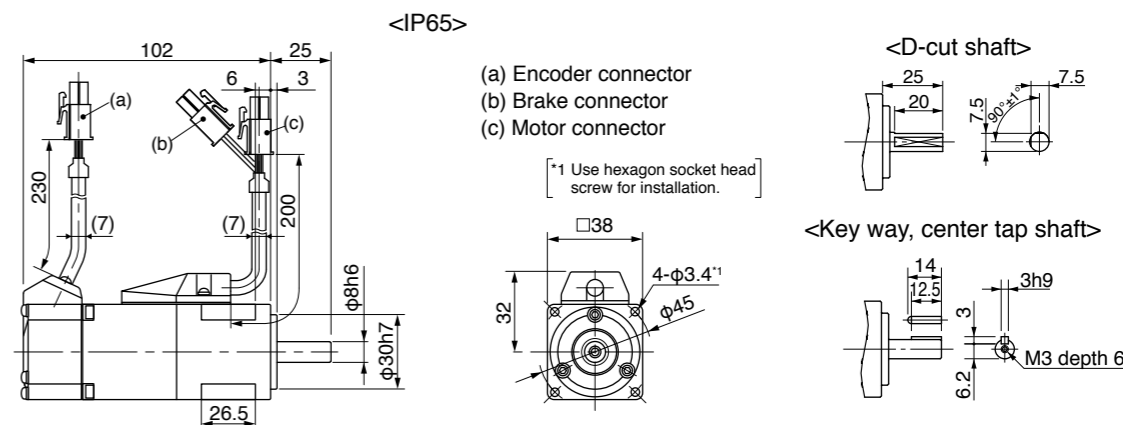

\* For the dimensions without brake, refer to the left page.

[Unit: mm]

<Cautions> Reduce the moment of inertia ratio if high speed response operation is required. Dimensions are subject to change without notice. Contact us or a dealer for the latest information. Read the Instruction Manual carefully and understand all precautions and remarks before using the products.

**Specifications**

		AC100 V	
Motor model *1	IP65	MSMD011G1□	MSMD011S1□
	IP67	-	-
Applicable driver *2	Model No.	A5II, A5 series	MAD◇T1107
		A5IE, A5E series	MAD◇T1107E
	Frame symbol	A-frame	
Power supply capacity (kVA)	0.4		
Rated output (W)	100		
Rated torque (N·m)	0.32		
Momentary Max. peak torque (N·m)	0.95		
Rated current (A(rms))	1.7		
Max. current (A(o-p))	7.2		
Regenerative brake frequency (times/min) Note1	Without option	No limit	Note2
	DV0P4280	No limit	Note2
Rated rotational speed (r/min)	3000		
Max. rotational speed (r/min)	5000		
Moment of inertia of rotor ( $\times 10^{-4}$ kg·m <sup>2</sup> )	Without brake	0.051	
	With brake	0.054	
Recommended moment of inertia ratio of the load and the rotor Note3	30 times or less		
Rotary encoder specifications Note5	20-bit Incremental	17-bit Absolute	
	Resolution per single turn	1,048,576	131,072

**• Brake specifications** (For details, refer to P.183)  
(This brake will be released when it is energized.)  
(Do not use this for braking the motor in motion.)

Static friction torque (N·m)	0.29 or more
Engaging time (ms)	35 or less
Releasing time (ms) Note4	20 or less
Exciting current (DC) (A)	0.3
Releasing voltage (DC) (V)	1 or more
Exciting voltage (DC) (V)	24±1.2

**• Permissible load** (For details, refer to P.183)

During assembly	Radial load P-direction (N)	147
	Thrust load A-direction (N)	88
	Thrust load B-direction (N)	117.6
During operation	Radial load P-direction (N)	68.6
	Thrust load A, B-direction (N)	58.8

• For details of Note 1 to Note 5, refer to P.182, 183.  
• Dimensions of Driver, refer to P.42.

- \*1 Motor specifications: □
- \*2 The product that the end of driver model designation has "E" is "Position control type". Detail of model designation, refer to P.16.
- \*3 ◇ in number of applicable driver represents the series. For more information about the part number, please refer to P.16.

**Torque characteristics (at AC100 V of power voltage <Dotted line represents the torque at 10 % less supply voltage.>)**

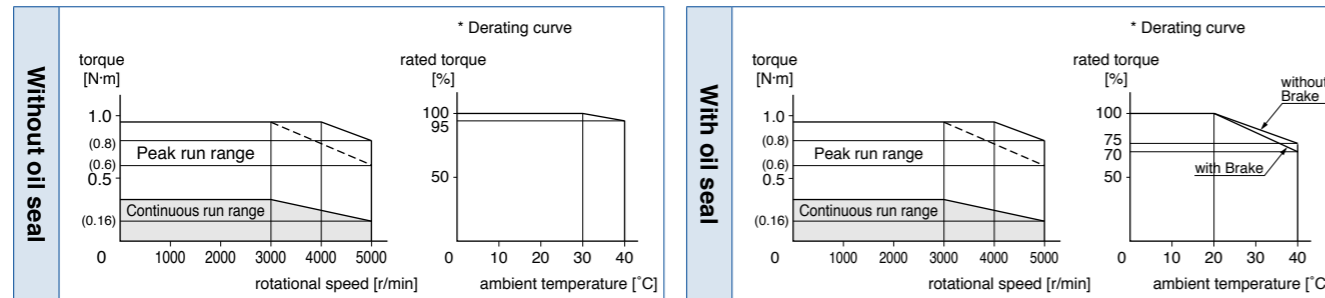

**Dimensions**

<Without Brake> Mass: 0.47 kg

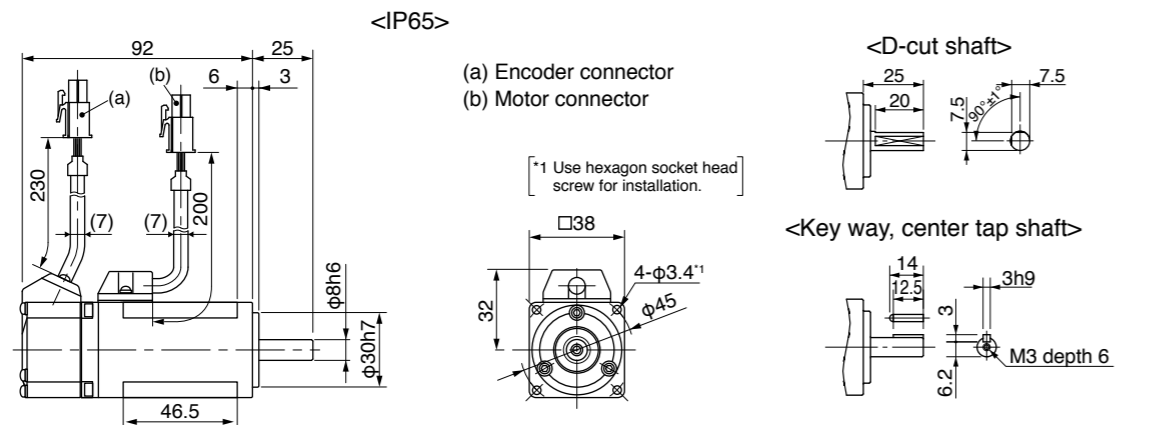

\* For the dimensions with brake, refer to the right page.

**<Cautions>** Reduce the moment of inertia ratio if high speed response operation is required. Dimensions are subject to change without notice. Contact us or a dealer for the latest information. Read the Instruction Manual carefully and understand all precautions and remarks before using the products.

**Specifications**

		AC200 V	
Motor model *1	IP65	MSMD012G1□	MSMD012S1□
	IP67	-	-
Applicable driver *2	Model No.	A5II, A5 series	MAD◇T1505
		A5IE, A5E series	MAD◇T1505E
	Frame symbol	A-frame	
Power supply capacity (kVA)	0.5		
Rated output (W)	100		
Rated torque (N·m)	0.32		
Momentary Max. peak torque (N·m)	0.95		
Rated current (A(rms))	1.1		
Max. current (A(o-p))	4.7		
Regenerative brake frequency (times/min) Note1	Without option	No limit	Note2
	DV0P4281	No limit	Note2
Rated rotational speed (r/min)	3000		
Max. rotational speed (r/min)	5000		
Moment of inertia of rotor ( $\times 10^{-4}$ kg·m <sup>2</sup> )	Without brake	0.051	
	With brake	0.054	
Recommended moment of inertia ratio of the load and the rotor Note3	30 times or less		
Rotary encoder specifications Note5	20-bit Incremental	17-bit Absolute	
	Resolution per single turn	1,048,576	131,072

**• Brake specifications** (For details, refer to P.183)  
(This brake will be released when it is energized.)  
(Do not use this for braking the motor in motion.)

Static friction torque (N·m)	0.29 or more
Engaging time (ms)	35 or less
Releasing time (ms) Note4	20 or less
Exciting current (DC) (A)	0.3
Releasing voltage (DC) (V)	1 or more
Exciting voltage (DC) (V)	24±1.2

**• Permissible load** (For details, refer to P.183)

During assembly	Radial load P-direction (N)	147
	Thrust load A-direction (N)	88
	Thrust load B-direction (N)	117.6
During operation	Radial load P-direction (N)	68.6
	Thrust load A, B-direction (N)	58.8

• For details of Note 1 to Note 5, refer to P.182, 183.  
• Dimensions of Driver, refer to P.42.

- \*1 Motor specifications: □
- \*2 The product that the end of driver model designation has "E" is "Position control type". Detail of model designation, refer to P.16.
- \*3 ◇ in number of applicable driver represents the series. For more information about the part number, please refer to P.16.

**Torque characteristics (at AC200 V of power voltage)**

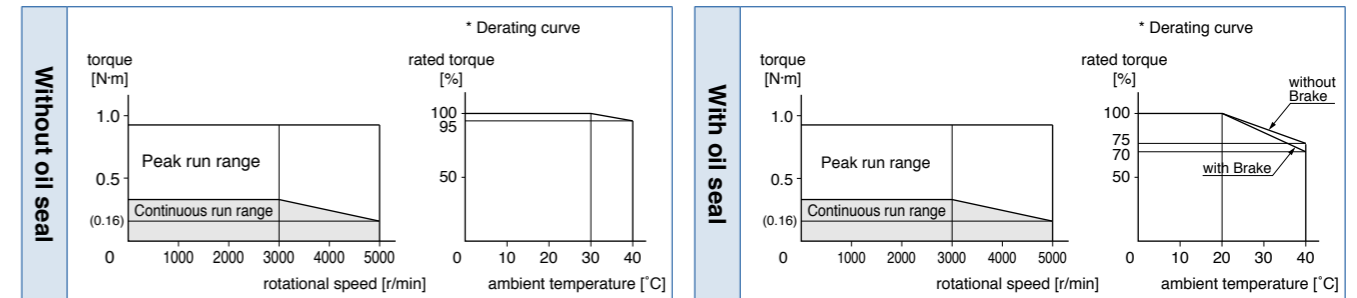

**Dimensions**

<With Brake> Mass: 0.68 kg

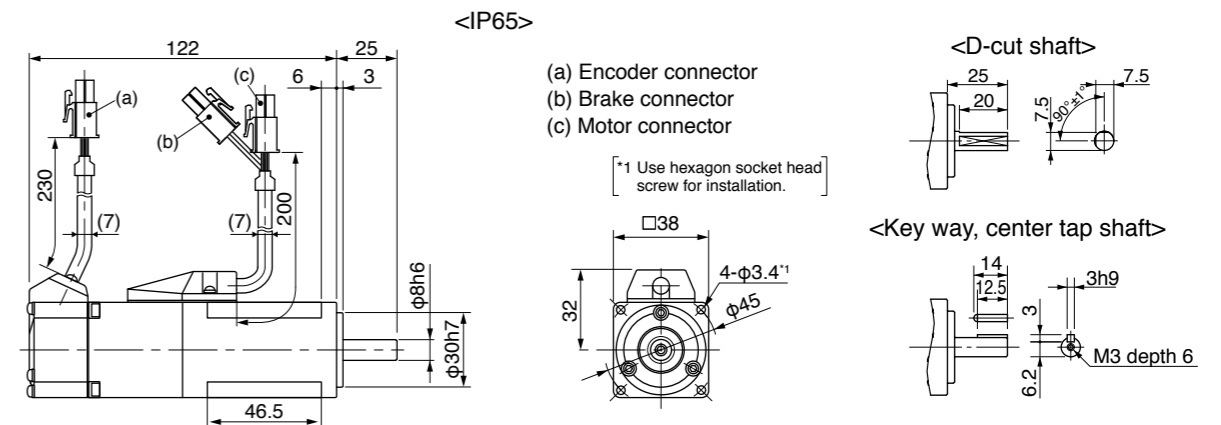

\* For the dimensions without brake, refer to the left page.

**<Cautions>** Reduce the moment of inertia ratio if high speed response operation is required. Dimensions are subject to change without notice. Contact us or a dealer for the latest information. Read the Instruction Manual carefully and understand all precautions and remarks before using the products.

[Unit: mm]

Specifications

		AC100 V	
Motor model *1	IP65	MSMD021G1□	MSMD021S1□
	IP67	-	-
Applicable driver *2	Model No.	A5II, A5 series	MBD◇T2110
	A5IE, A5E series	MBD◇T2110E	-
Frame symbol		B-frame	
Power supply capacity (kVA)	0.5		
Rated output (W)	200		
Rated torque (N·m)	0.64		
Momentary Max. peak torque (N·m)	1.91		
Rated current (A(rms))	2.5		
Max. current (A(o-p))	10.6		
Regenerative brake frequency (times/min) Note1	Without option	No limit	Note2
	DV0P4283	No limit	Note2
Rated rotational speed (r/min)	3000		
Max. rotational speed (r/min)	5000		
Moment of inertia of rotor (x10 <sup>-4</sup> kg·m <sup>2</sup> )	Without brake	0.14	
	With brake	0.16	
Recommended moment of inertia ratio of the load and the rotor Note3	30 times or less		
Rotary encoder specifications Note5	20-bit Incremental	17-bit Absolute	
	Resolution per single turn	1,048,576	131,072

• Brake specifications (For details, refer to P.183)

(This brake will be released when it is energized.)  
(Do not use this for braking the motor in motion.)

Static friction torque (N·m)	1.27 or more
Engaging time (ms)	50 or less
Releasing time (ms) Note4	15 or less
Exciting current (DC) (A)	0.36
Releasing voltage (DC) (V)	1 or more
Exciting voltage (DC) (V)	24±1.2

• Permissible load (For details, refer to P.183)

During assembly	Radial load P-direction (N)	392
	Thrust load A-direction (N)	147
	Thrust load B-direction (N)	196
During operation	Radial load P-direction (N)	245
	Thrust load A, B-direction (N)	98

• For details of Note 1 to Note 5, refer to P.182, 183.

• Dimensions of Driver, refer to P.42.

\*1 Motor specifications: □

\*2 The product that the end of driver model designation has "E" is "Position control type". Detail of model designation, refer to P.16.

\*3 ◇ in number of applicable driver represents the series. For more information about the part number, please refer to P.16.

Torque characteristics (at AC100 V of power voltage <Dotted line represents the torque at 10% less supply voltage.>)

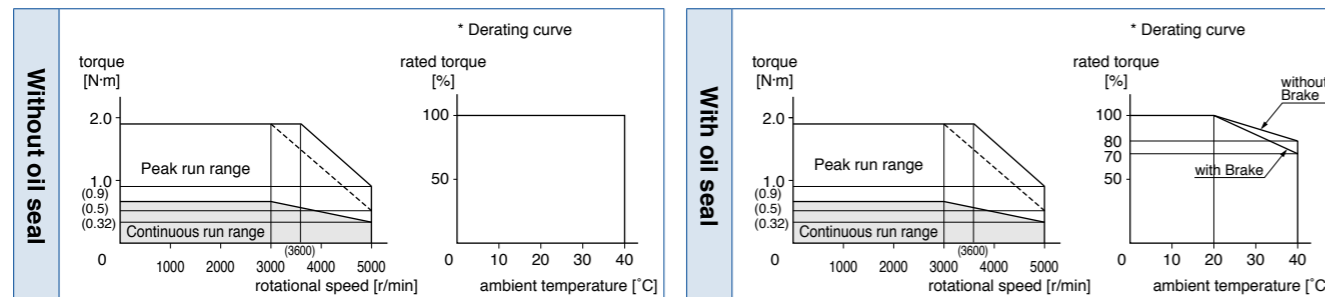

Dimensions

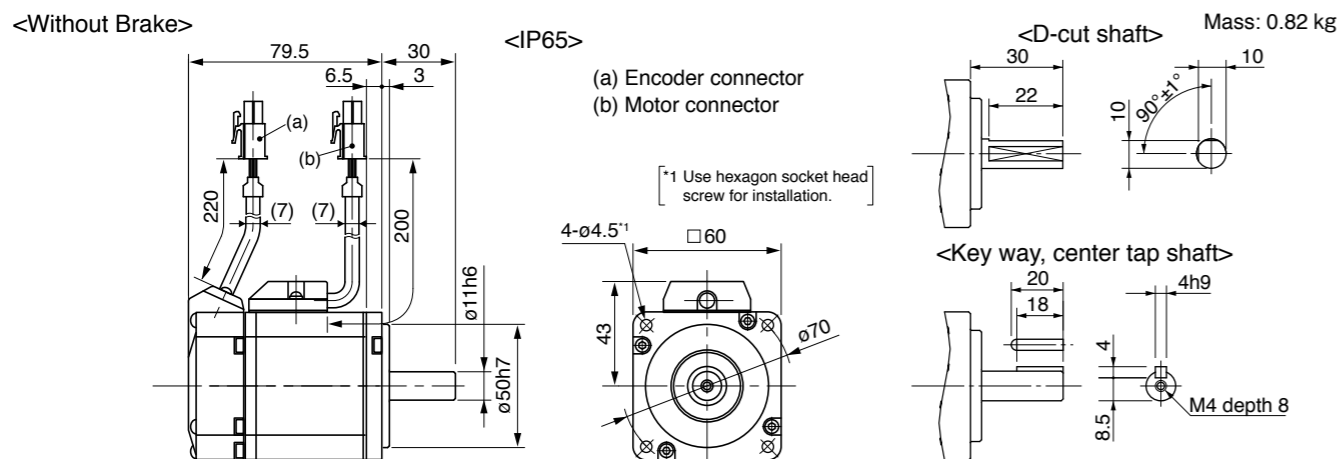

\* For the dimensions with brake, refer to the right page.

[Unit: mm]

<Cautions> Reduce the moment of inertia ratio if high speed response operation is required. Dimensions are subject to change without notice. Contact us or a dealer for the latest information. Read the Instruction Manual carefully and understand all precautions and remarks before using the products.

Specifications

		AC200 V	
Motor model *1	IP65	MSMD022G1□	MSMD022S1□
	IP67	-	-
Applicable driver *2	Model No.	A5II, A5 series	MAD◇T1507
	A5IE, A5E series	MAD◇T1507E	-
Frame symbol		A-frame	
Power supply capacity (kVA)	0.5		
Rated output (W)	200		
Rated torque (N·m)	0.64		
Momentary Max. peak torque (N·m)	1.91		
Rated current (A(rms))	1.6		
Max. current (A(o-p))	6.9		
Regenerative brake frequency (times/min) Note1	Without option	No limit	Note2
	DV0P4283	No limit	Note2
Rated rotational speed (r/min)	3000		
Max. rotational speed (r/min)	5000		
Moment of inertia of rotor (x10 <sup>-4</sup> kg·m <sup>2</sup> )	Without brake	0.14	
	With brake	0.16	
Recommended moment of inertia ratio of the load and the rotor Note3	30 times or less		
Rotary encoder specifications Note5	20-bit Incremental	17-bit Absolute	
	Resolution per single turn	1,048,576	131,072

• Brake specifications (For details, refer to P.183)

(This brake will be released when it is energized.)  
(Do not use this for braking the motor in motion.)

Static friction torque (N·m)	1.27 or more
Engaging time (ms)	50 or less
Releasing time (ms) Note4	15 or less
Exciting current (DC) (A)	0.36
Releasing voltage (DC) (V)	1 or more
Exciting voltage (DC) (V)	24±1.2

• Permissible load (For details, refer to P.183)

During assembly	Radial load P-direction (N)	392
	Thrust load A-direction (N)	147
	Thrust load B-direction (N)	196
During operation	Radial load P-direction (N)	245
	Thrust load A, B-direction (N)	98

• For details of Note 1 to Note 5, refer to P.182, 183.

• Dimensions of Driver, refer to P.42.

\*1 Motor specifications: □

\*2 The product that the end of driver model designation has "E" is "Position control type". Detail of model designation, refer to P.16.

\*3 ◇ in number of applicable driver represents the series. For more information about the part number, please refer to P.16.

Torque characteristics (at AC200 V of power voltage <Dotted line represents the torque at 10% less supply voltage.>)

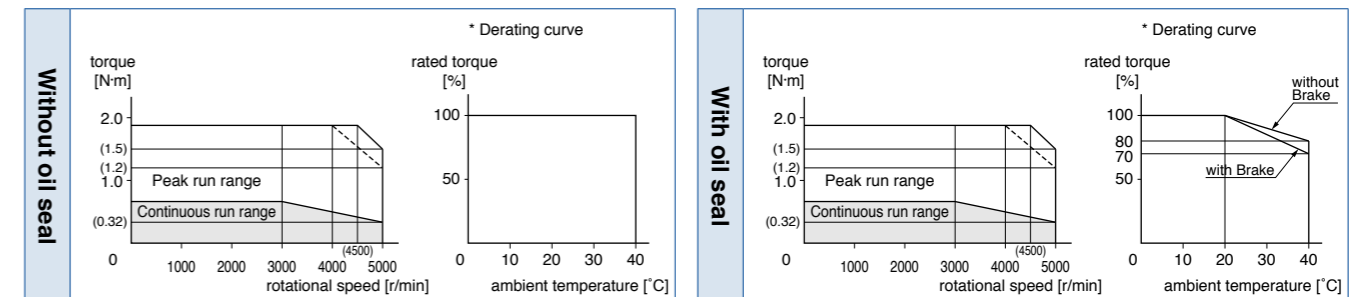

Dimensions

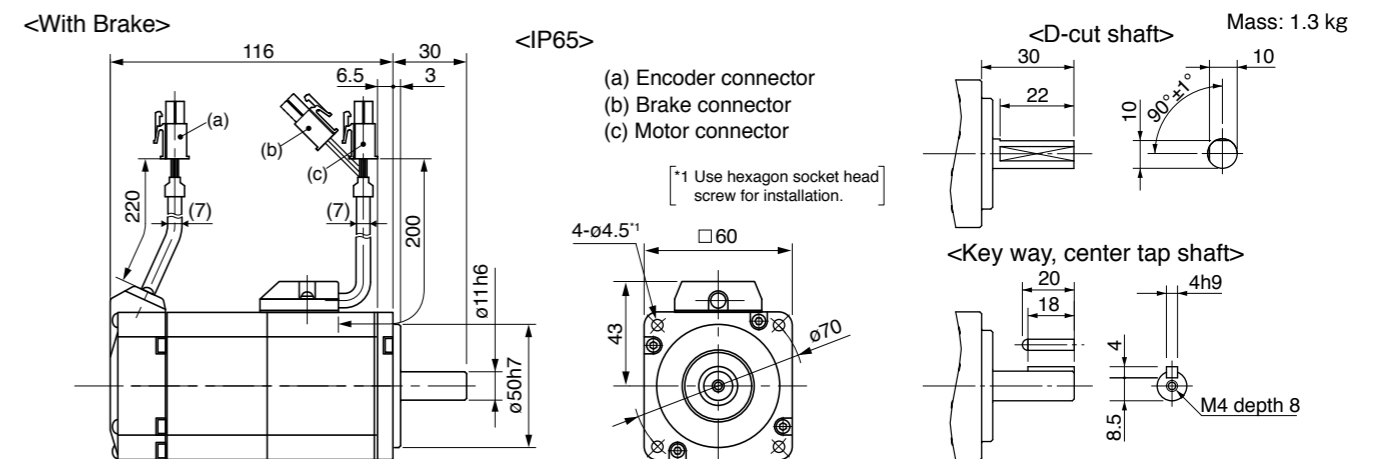

\* For the dimensions without brake, refer to the left page.

[Unit: mm]

<Cautions> Reduce the moment of inertia ratio if high speed response operation is required. Dimensions are subject to change without notice. Contact us or a dealer for the latest information. Read the Instruction Manual carefully and understand all precautions and remarks before using the products.

Specifications

		AC100 V	
Motor model *1	IP65	MSMD041G1□	MSMD041S1□
	IP67	-	-
Applicable driver *2	Model No.	A5II, A5 series	MCD◇T3120
		A5IE, A5E series	MCD◇T3120E
Frame symbol		C-frame	
Power supply capacity (kVA)	0.9		
Rated output (W)	400		
Rated torque (N·m)	1.3		
Momentary Max. peak torque (N·m)	3.8		
Rated current (A(rms))	4.6		
Max. current (A(o-p))	19.5		
Regenerative brake frequency (times/min) Note1	Without option	No limit Note2	
	DV0P4282	No limit Note2	
Rated rotational speed (r/min)	3000		
Max. rotational speed (r/min)	5000		
Moment of inertia of rotor (×10 <sup>-4</sup> kg·m <sup>2</sup> )	Without brake	0.26	
	With brake	0.28	
Recommended moment of inertia ratio of the load and the rotor Note3	30 times or less		
Rotary encoder specifications Note5	20-bit Incremental	17-bit Absolute	
	Resolution per single turn	1,048,576	131,072

• **Brake specifications** (For details, refer to P.183)  
 (This brake will be released when it is energized.)  
 (Do not use this for braking the motor in motion.)

Static friction torque (N·m)	1.27 or more
Engaging time (ms)	50 or less
Releasing time (ms) Note4	15 or less
Exciting current (DC) (A)	0.36
Releasing voltage (DC) (V)	1 or more
Exciting voltage (DC) (V)	24±1.2

• **Permissible load** (For details, refer to P.183)

During assembly	Radial load P-direction (N)	392
	Thrust load A-direction (N)	147
	Thrust load B-direction (N)	196
During operation	Radial load P-direction (N)	245
	Thrust load A, B-direction (N)	98

• For details of Note 1 to Note 5, refer to P.182, 183.

• Dimensions of Driver, refer to P.43.

\*1 Motor specifications: □

\*2 The product that the end of driver model designation has "E" is "Position control type". Detail of model designation, refer to P.16.

\*3 ◇ in number of applicable driver represents the series. For more information about the part number, please refer to P.16.

Torque characteristics (at AC100 V of power voltage <Dotted line represents the torque at 10 % less supply voltage.>)

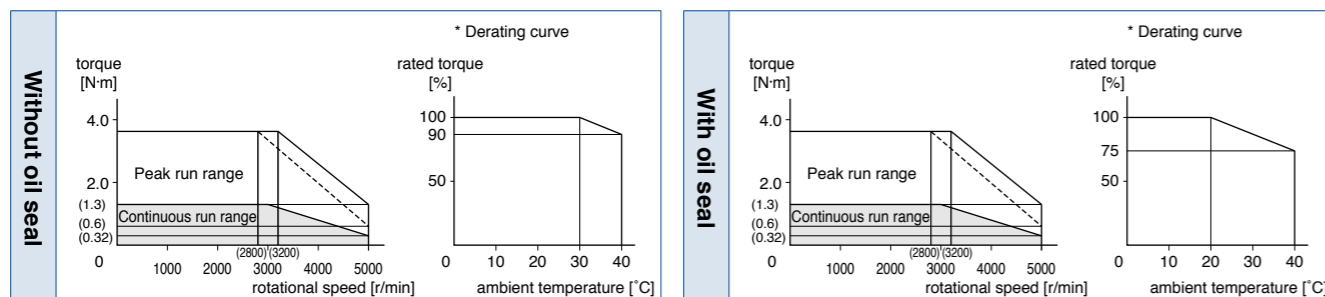

Dimensions

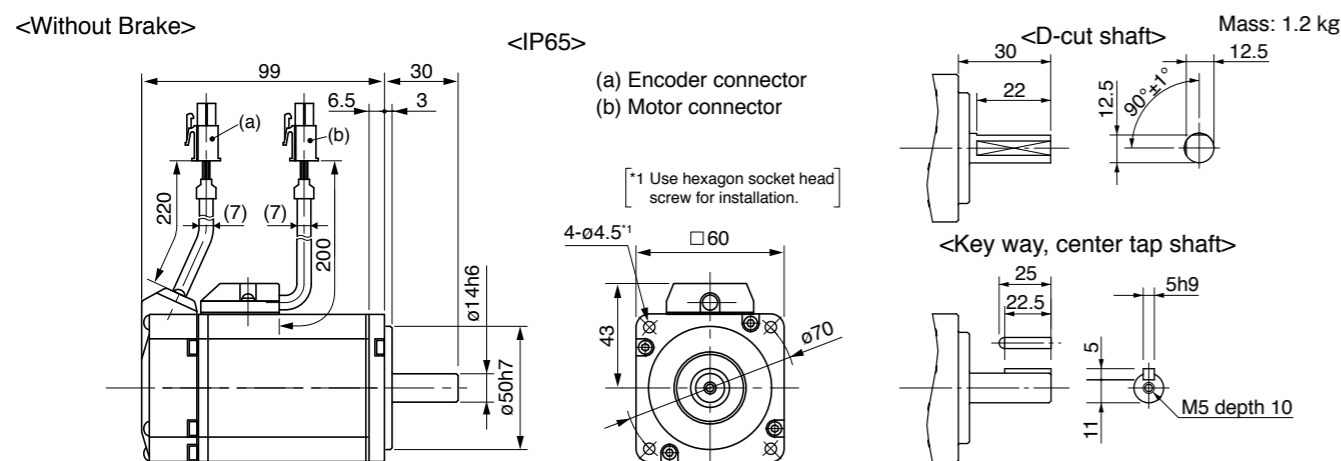

\* For the dimensions with brake, refer to the right page.

[Unit: mm]

<Cautions> Reduce the moment of inertia ratio if high speed response operation is required. Dimensions are subject to change without notice. Contact us or a dealer for the latest information. Read the Instruction Manual carefully and understand all precautions and remarks before using the products.

Specifications

		AC200 V	
Motor model *1	IP65	MSMD042G1□	MSMD042S1□
	IP67	-	-
Applicable driver *2	Model No.	A5II, A5 series	MBD◇T2510
		A5IE, A5E series	MBD◇T2510E
Frame symbol		B-frame	
Power supply capacity (kVA)	0.9		
Rated output (W)	400		
Rated torque (N·m)	1.3		
Momentary Max. peak torque (N·m)	3.8		
Rated current (A(rms))	2.6		
Max. current (A(o-p))	11.0		
Regenerative brake frequency (times/min) Note1	Without option	No limit Note2	
	DV0P4283	No limit Note2	
Rated rotational speed (r/min)	3000		
Max. rotational speed (r/min)	5000		
Moment of inertia of rotor (×10 <sup>-4</sup> kg·m <sup>2</sup> )	Without brake	0.26	
	With brake	0.28	
Recommended moment of inertia ratio of the load and the rotor Note3	30 times or less		
Rotary encoder specifications Note5	20-bit Incremental	17-bit Absolute	
	Resolution per single turn	1,048,576	131,072

• **Brake specifications** (For details, refer to P.183)  
 (This brake will be released when it is energized.)  
 (Do not use this for braking the motor in motion.)

Static friction torque (N·m)	1.27 or more
Engaging time (ms)	50 or less
Releasing time (ms) Note4	15 or less
Exciting current (DC) (A)	0.36
Releasing voltage (DC) (V)	1 or more
Exciting voltage (DC) (V)	24±1.2

• **Permissible load** (For details, refer to P.183)

During assembly	Radial load P-direction (N)	392
	Thrust load A-direction (N)	147
	Thrust load B-direction (N)	196
During operation	Radial load P-direction (N)	245
	Thrust load A, B-direction (N)	98

• For details of Note 1 to Note 5, refer to P.182, 183.

• Dimensions of Driver, refer to P.42.

\*1 Motor specifications: □

\*2 The product that the end of driver model designation has "E" is "Position control type". Detail of model designation, refer to P.16.

\*3 ◇ in number of applicable driver represents the series. For more information about the part number, please refer to P.16.

Torque characteristics (at AC200 V of power voltage <Dotted line represents the torque at 10 % less supply voltage.>)

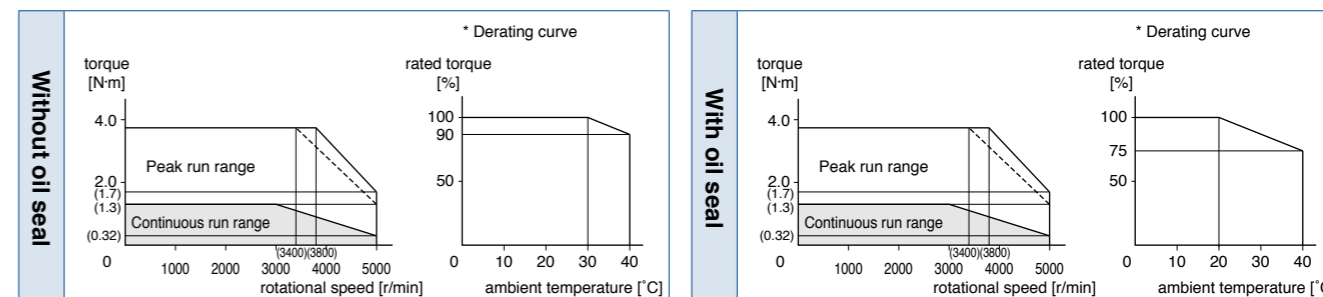

Dimensions

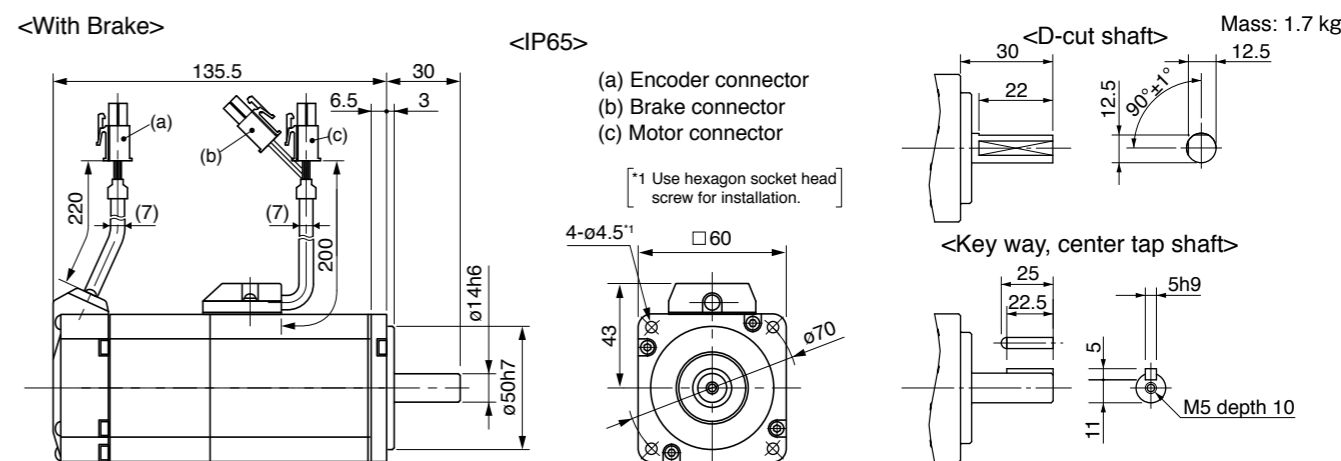

\* For the dimensions without brake, refer to the left page.

[Unit: mm]

<Cautions> Reduce the moment of inertia ratio if high speed response operation is required. Dimensions are subject to change without notice. Contact us or a dealer for the latest information. Read the Instruction Manual carefully and understand all precautions and remarks before using the products.

Specifications

		AC200 V	
Motor model *1	IP65	MSMD082G1□	MSMD082S1□
	IP67	-	-
Applicable driver *2	Model No.	A5I, A5 series	MCD◇T3520
		A5IE, A5E series	MCD◇T3520E
	Frame symbol	C-frame	
Power supply capacity (kVA)	1.3		
Rated output (W)	750		
Rated torque (N·m)	2.4		
Momentary Max. peak torque (N·m)	7.1		
Rated current (A(rms))	4.0		
Max. current (A(o-p))	17.0		
Regenerative brake frequency (times/min) Note1	Without option	No limit Note2	
	DV0P4283	No limit Note2	
Rated rotational speed (r/min)	3000		
Max. rotational speed (r/min)	4500		
Moment of inertia of rotor (x10 <sup>-4</sup> kg·m <sup>2</sup> )	Without brake	0.87	
	With brake	0.97	
Recommended moment of inertia ratio of the load and the rotor Note3	20 times or less		
Rotary encoder specifications Note5	20-bit Incremental	17-bit Absolute	
	Resolution per single turn	1,048,576	131,072

• Brake specifications (For details, refer to P.183)

(This brake will be released when it is energized.)  
(Do not use this for braking the motor in motion.)

Static friction torque (N·m)	2.45 or more
Engaging time (ms)	70 or less
Releasing time (ms) Note4	20 or less
Exciting current (DC) (A)	0.42
Releasing voltage (DC) (V)	1 or more
Exciting voltage (DC) (V)	24±1.2

• Permissible load (For details, refer to P.183)

During assembly	Radial load P-direction (N)	686
	Thrust load A-direction (N)	294
	Thrust load B-direction (N)	392
During operation	Radial load P-direction (N)	392
	Thrust load A, B-direction (N)	147

• For details of Note 1 to Note 5, refer to P.182, 183.

• Dimensions of Driver, refer to P.43.

\*1 Motor specifications: □

\*2 The product that the end of driver model designation has "E" is "Position control type".  
Detail of model designation, refer to P.16.

\*3 ◇ in number of applicable driver represents the series. For more information about the part number, please refer to P.16.

Torque characteristics (at AC200 V of power voltage <Dotted line represents the torque at 10% less supply voltage.>)

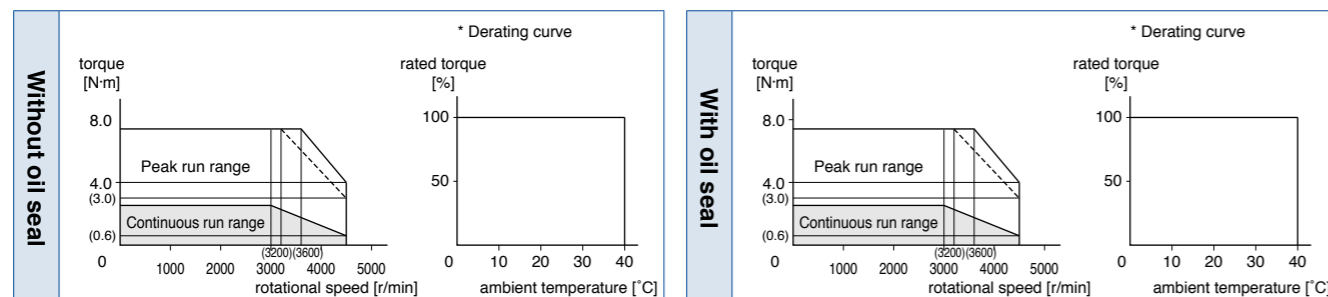

Dimensions

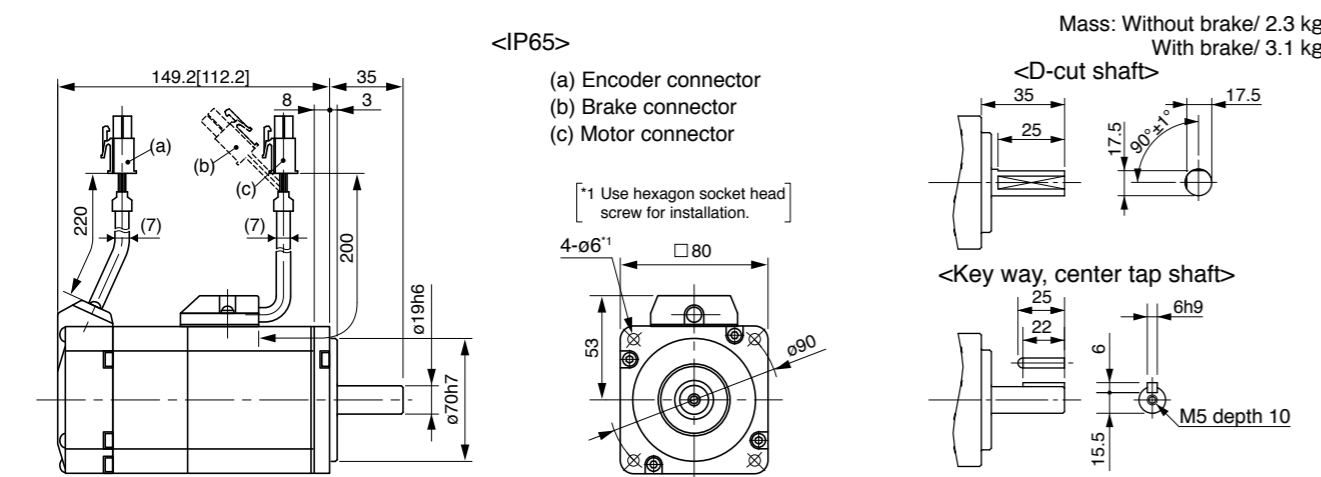

\* Figures in [ ] represent the dimensions without brake.

[Unit: mm]

<Cautions> Reduce the moment of inertia ratio if high speed response operation is required.  
Dimensions are subject to change without notice. Contact us or a dealer for the latest information.  
Read the Instruction Manual carefully and understand all precautions and remarks before using the products.

MEMO

Specifications

		AC100 V	
Motor model *1	IP65	MHMD021G1□	MHMD021S1□
	IP67	-	-
Applicable driver *2	Model No.	A5II, A5 series	MBD◇T2110
	A5IE, A5E series	MBD◇T2110E	-
Frame symbol		B-frame	
Power supply capacity (kVA)	0.5		
Rated output (W)	200		
Rated torque (N·m)	0.64		
Momentary Max. peak torque (N·m)	1.91		
Rated current (A(rms))	2.5		
Max. current (A(o-p))	10.6		
Regenerative brake frequency (times/min) Note1	Without option	No limit Note2	
	DV0P4283	No limit Note2	
Rated rotational speed (r/min)	3000		
Max. rotational speed (r/min)	5000		
Moment of inertia of rotor (×10 <sup>-4</sup> kg·m <sup>2</sup> )	Without brake	0.42	
	With brake	0.45	
Recommended moment of inertia ratio of the load and the rotor Note3	30 times or less		
Rotary encoder specifications Note5	20-bit Incremental	17-bit Absolute	
	Resolution per single turn	1,048,576	131,072

• **Brake specifications** (For details, refer to P.183)  
 (This brake will be released when it is energized.)  
 (Do not use this for braking the motor in motion.)

Static friction torque (N·m)	1.27 or more
Engaging time (ms)	50 or less
Releasing time (ms) Note4	15 or less
Exciting current (DC) (A)	0.36
Releasing voltage (DC) (V)	1 or more
Exciting voltage (DC) (V)	24±1.2

• **Permissible load** (For details, refer to P.183)

During assembly	Radial load P-direction (N)	392
	Thrust load A-direction (N)	147
	Thrust load B-direction (N)	196
During operation	Radial load P-direction (N)	245
	Thrust load A, B-direction (N)	98

• For details of Note 1 to Note 5, refer to P.182, 183.  
 • Dimensions of Driver, refer to P.42.

- \*1 Motor specifications: □
- \*2 The product that the end of driver model designation has "E" is "Position control type". Detail of model designation, refer to P.16.
- \*3 ◇ in number of applicable driver represents the series. For more information about the part number, please refer to P.16.

Torque characteristics (at AC100 V of power voltage <Dotted line represents the torque at 10% less supply voltage.>)

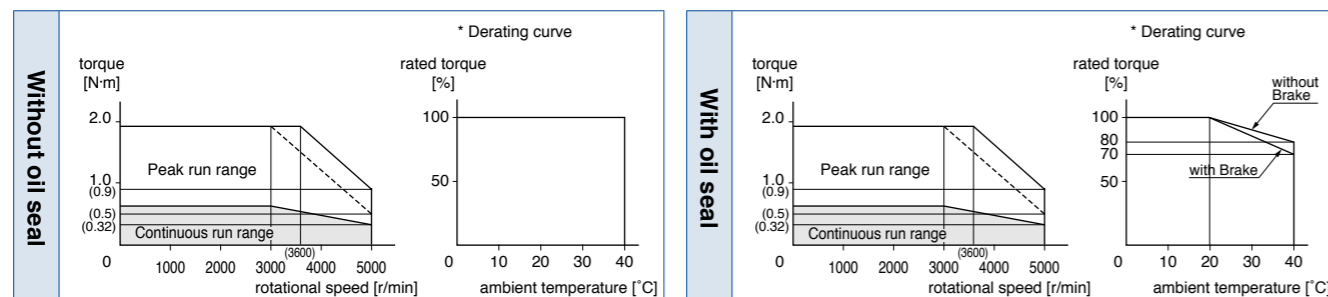

Dimensions

<Without Brake> <IP65> Mass: 0.96 kg

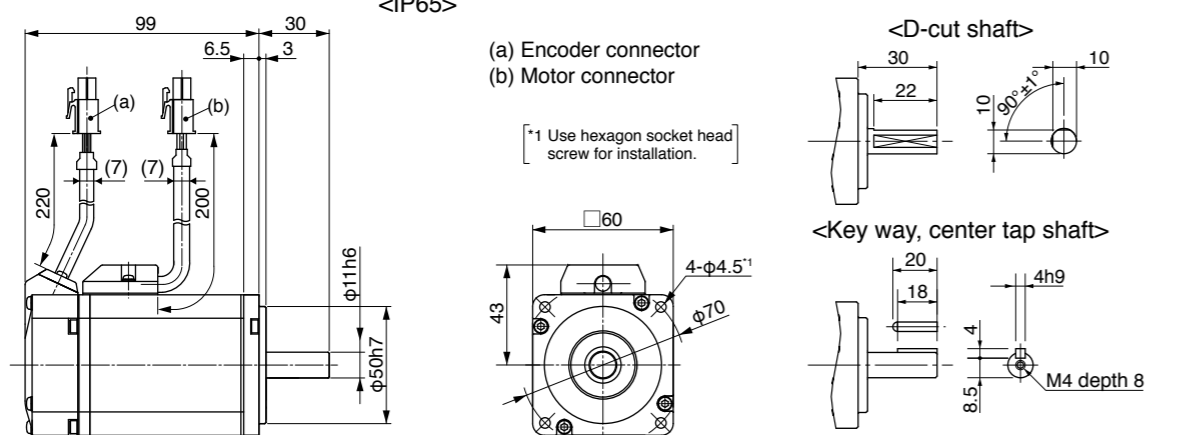

\* For the dimensions with brake, refer to the right page.

<Cautions> Reduce the moment of inertia ratio if high speed response operation is required. Dimensions are subject to change without notice. Contact us or a dealer for the latest information. Read the Instruction Manual carefully and understand all precautions and remarks before using the products.

Specifications

		AC200 V	
Motor model *1	IP65	MHMD022G1□	MHMD022S1□
	IP67	-	-
Applicable driver *2	Model No.	A5II, A5 series	MAD◇T1507
	A5IE, A5E series	MAD◇T1507E	-
Frame symbol		A-frame	
Power supply capacity (kVA)	0.5		
Rated output (W)	200		
Rated torque (N·m)	0.64		
Momentary Max. peak torque (N·m)	1.91		
Rated current (A(rms))	1.6		
Max. current (A(o-p))	6.9		
Regenerative brake frequency (times/min) Note1	Without option	No limit Note2	
	DV0P4283	No limit Note2	
Rated rotational speed (r/min)	3000		
Max. rotational speed (r/min)	5000		
Moment of inertia of rotor (×10 <sup>-4</sup> kg·m <sup>2</sup> )	Without brake	0.42	
	With brake	0.45	
Recommended moment of inertia ratio of the load and the rotor Note3	30 times or less		
Rotary encoder specifications Note5	20-bit Incremental	17-bit Absolute	
	Resolution per single turn	1,048,576	131,072

• **Brake specifications** (For details, refer to P.183)  
 (This brake will be released when it is energized.)  
 (Do not use this for braking the motor in motion.)

Static friction torque (N·m)	1.27 or more
Engaging time (ms)	50 or less
Releasing time (ms) Note4	15 or less
Exciting current (DC) (A)	0.36
Releasing voltage (DC) (V)	1 or more
Exciting voltage (DC) (V)	24±1.2

• **Permissible load** (For details, refer to P.183)

During assembly	Radial load P-direction (N)	392
	Thrust load A-direction (N)	147
	Thrust load B-direction (N)	196
During operation	Radial load P-direction (N)	245
	Thrust load A, B-direction (N)	98

• For details of Note 1 to Note 5, refer to P.182, 183.  
 • Dimensions of Driver, refer to P.42.

- \*1 Motor specifications: □
- \*2 The product that the end of driver model designation has "E" is "Position control type". Detail of model designation, refer to P.16.
- \*3 ◇ in number of applicable driver represents the series. For more information about the part number, please refer to P.16.

Torque characteristics (at AC200 V of power voltage <Dotted line represents the torque at 10% less supply voltage.>)

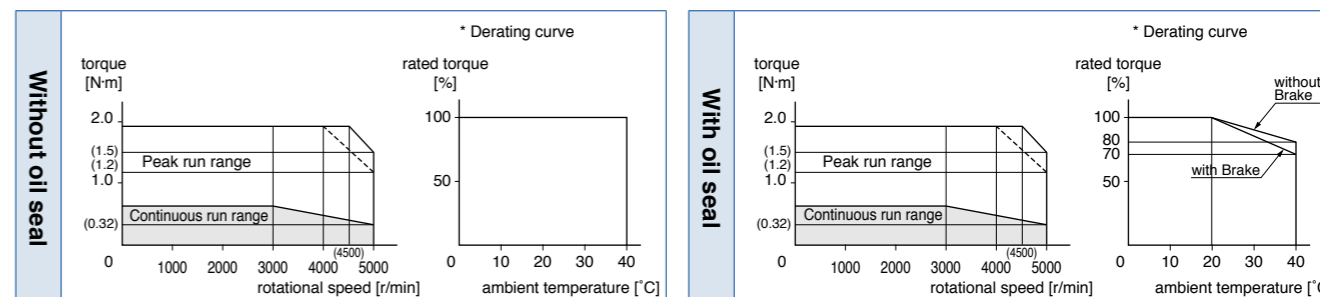

Dimensions

<With Brake> <IP65> Mass: 1.4 kg

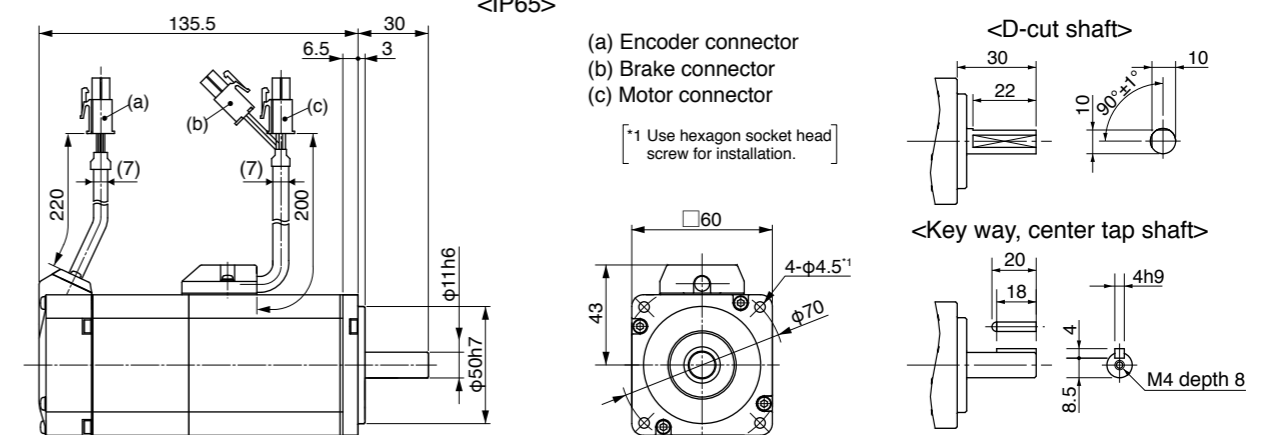

\* For the dimensions without brake, refer to the left page.

<Cautions> Reduce the moment of inertia ratio if high speed response operation is required. Dimensions are subject to change without notice. Contact us or a dealer for the latest information. Read the Instruction Manual carefully and understand all precautions and remarks before using the products.

Specifications

		AC100 V	
Motor model *1	IP65	MHMD041G1□	MHMD041S1□
	IP67	-	-
Applicable driver *2	Model No.	A5I, A5 series	MCD◇T3120
	A5IE, A5E series	MCD◇T3120E	-
Frame symbol		C-frame	
Power supply capacity (kVA)	0.9		
Rated output (W)	400		
Rated torque (N·m)	1.3		
Momentary Max. peak torque (N·m)	3.8		
Rated current (A(rms))	4.6		
Max. current (A(o-p))	19.5		
Regenerative brake frequency (times/min) Note1	Without option	No limit	Note2
	DV0P4282	No limit	Note2
Rated rotational speed (r/min)	3000		
Max. rotational speed (r/min)	5000		
Moment of inertia of rotor (×10 <sup>-4</sup> kg·m <sup>2</sup> )	Without brake	0.67	
	With brake	0.70	
Recommended moment of inertia ratio of the load and the rotor Note3	30 times or less		
Rotary encoder specifications Note5	20-bit Incremental	17-bit Absolute	
	Resolution per single turn	1,048,576	131,072

• **Brake specifications** (For details, refer to P.183)  
 (This brake will be released when it is energized.)  
 (Do not use this for braking the motor in motion.)

Static friction torque (N·m)	1.27 or more
Engaging time (ms)	50 or less
Releasing time (ms) Note4	15 or less
Exciting current (DC) (A)	0.36
Releasing voltage (DC) (V)	1 or more
Exciting voltage (DC) (V)	24±1.2

• **Permissible load** (For details, refer to P.183)

During assembly	Radial load P-direction (N)	392
	Thrust load A-direction (N)	147
	Thrust load B-direction (N)	196
During operation	Radial load P-direction (N)	245
	Thrust load A, B-direction (N)	98

• For details of Note 1 to Note 5, refer to P.182, 183.

• Dimensions of Driver, refer to P.43.

\*1 Motor specifications: □

\*2 The product that the end of driver model designation has "E" is "Position control type". Detail of model designation, refer to P.16.

\*3 ◇ in number of applicable driver represents the series. For more information about the part number, please refer to P.16.

Torque characteristics (at AC100 V of power voltage <Dotted line represents the torque at 10 % less supply voltage.>)

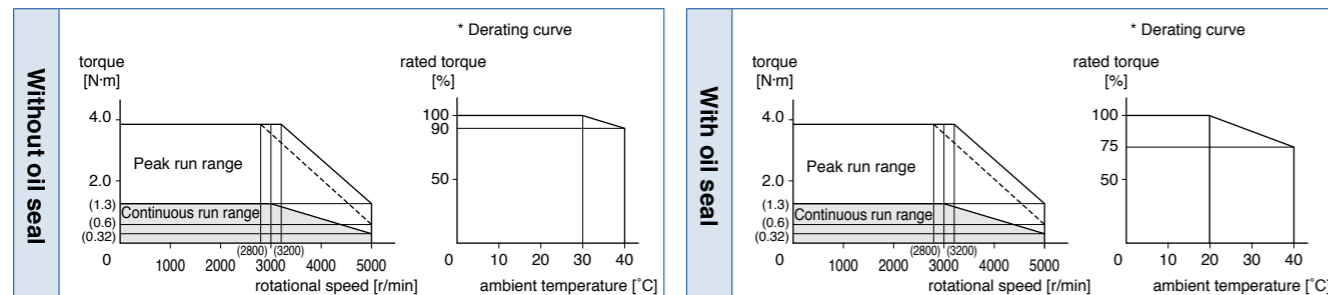

Dimensions

<Without Brake> <IP65> Mass: 1.4 kg

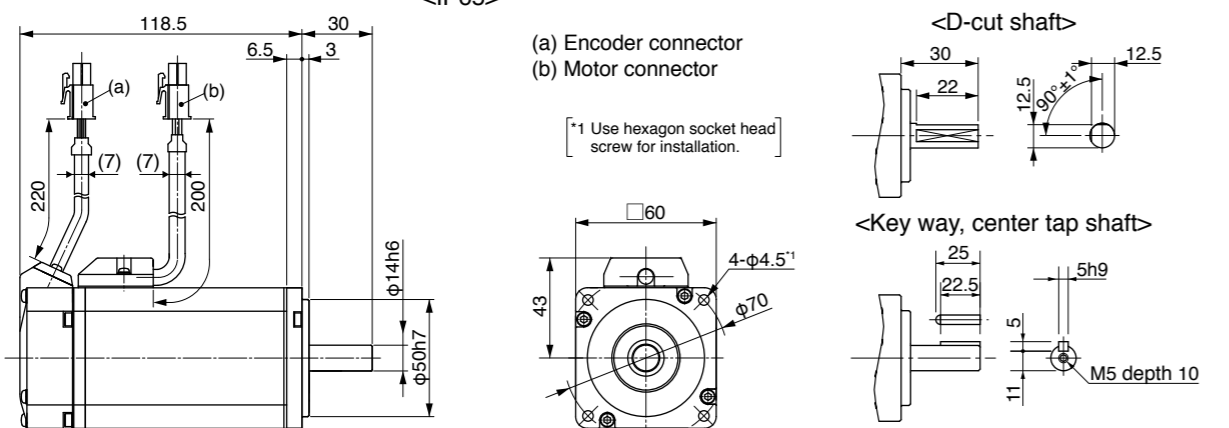

\* For the dimensions with brake, refer to the right page.

[Unit: mm]

<Cautions> Reduce the moment of inertia ratio if high speed response operation is required. Dimensions are subject to change without notice. Contact us or a dealer for the latest information. Read the Instruction Manual carefully and understand all precautions and remarks before using the products.

Specifications

		AC200 V	
Motor model *1	IP65	MHMD042G1□	MHMD042S1□
	IP67	-	-
Applicable driver *2	Model No.	A5I, A5 series	MBD◇T2510
	A5IE, A5E series	MBD◇T2510E	-
Frame symbol		B-frame	
Power supply capacity (kVA)	0.9		
Rated output (W)	400		
Rated torque (N·m)	1.3		
Momentary Max. peak torque (N·m)	3.8		
Rated current (A(rms))	2.6		
Max. current (A(o-p))	11.0		
Regenerative brake frequency (times/min) Note1	Without option	No limit	Note2
	DV0P4283	No limit	Note2
Rated rotational speed (r/min)	3000		
Max. rotational speed (r/min)	5000		
Moment of inertia of rotor (×10 <sup>-4</sup> kg·m <sup>2</sup> )	Without brake	0.67	
	With brake	0.70	
Recommended moment of inertia ratio of the load and the rotor Note3	30 times or less		
Rotary encoder specifications Note5	20-bit Incremental	17-bit Absolute	
	Resolution per single turn	1,048,576	131,072

• **Brake specifications** (For details, refer to P.183)  
 (This brake will be released when it is energized.)  
 (Do not use this for braking the motor in motion.)

Static friction torque (N·m)	1.27 or more
Engaging time (ms)	50 or less
Releasing time (ms) Note4	15 or less
Exciting current (DC) (A)	0.36
Releasing voltage (DC) (V)	1 or more
Exciting voltage (DC) (V)	24±1.2

• **Permissible load** (For details, refer to P.183)

During assembly	Radial load P-direction (N)	392
	Thrust load A-direction (N)	147
	Thrust load B-direction (N)	196
During operation	Radial load P-direction (N)	245
	Thrust load A, B-direction (N)	98

• For details of Note 1 to Note 5, refer to P.182, 183.

• Dimensions of Driver, refer to P.42.

\*1 Motor specifications: □

\*2 The product that the end of driver model designation has "E" is "Position control type". Detail of model designation, refer to P.16.

\*3 ◇ in number of applicable driver represents the series. For more information about the part number, please refer to P.16.

Torque characteristics (at AC200 V of power voltage <Dotted line represents the torque at 10 % less supply voltage.>)

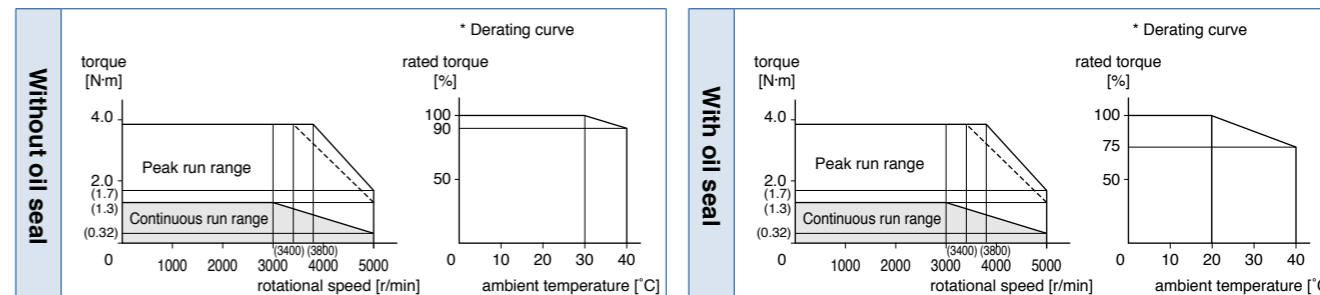

Dimensions

<With Brake> <IP65> Mass: 1.8 kg

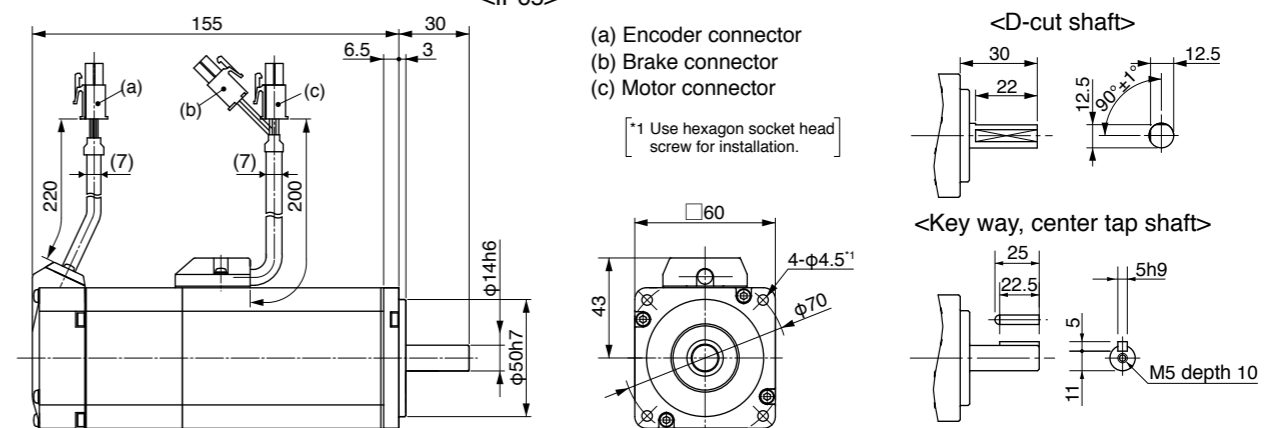

\* For the dimensions without brake, refer to the left page.

[Unit: mm]

<Cautions> Reduce the moment of inertia ratio if high speed response operation is required. Dimensions are subject to change without notice. Contact us or a dealer for the latest information. Read the Instruction Manual carefully and understand all precautions and remarks before using the products.





Specifications

		AC100 V	
Motor model *1	IP65	-	-
	IP67	MSME5AZG1□	MSME5AZS1□
Applicable driver *2	Model No. A5II, A5 series	MAD◇T1105	
	A5IE, A5E series	MAD◇T1105E	-
Frame symbol		A-frame	
Power supply capacity (kVA)		0.4	
Rated output (W)		50	
Rated torque (N·m)		0.16	
Momentary Max. peak torque (N·m)		0.48	
Rated current (A(rms))		1.1	
Max. current (A(o-p))		4.7	
Regenerative brake frequency (times/min) Note1	Without option	No limit Note2	
	DV0P4280	No limit Note2	
Rated rotational speed (r/min)		3000	
Max. rotational speed (r/min)		6000	
Moment of inertia of rotor ( $\times 10^{-4}$ kg·m <sup>2</sup> )	Without brake	0.025	
	With brake	0.027	
Recommended moment of inertia ratio of the load and the rotor Note3		30 times or less	
Rotary encoder specifications Note5	20-bit Incremental		17-bit Absolute
	Resolution per single turn	1,048,576	131,072

• Brake specifications (For details, refer to P.183)

(This brake will be released when it is energized.)  
(Do not use this for braking the motor in motion.)

Static friction torque (N·m)	0.29 or more
Engaging time (ms)	35 or less
Releasing time (ms) Note4	20 or less
Exciting current (DC) (A)	0.3
Releasing voltage (DC) (V)	1 or more
Exciting voltage (DC) (V)	24±1.2

• Permissible load (For details, refer to P.183)

During assembly	Radial load P-direction (N)	147
	Thrust load A-direction (N)	88
	Thrust load B-direction (N)	117.6
During operation	Radial load P-direction (N)	68.6
	Thrust load A, B-direction (N)	58.8

• For details of Note 1 to Note 5, refer to P.182, 183.

• Dimensions of Driver, refer to P.42.

\*1 Motor specifications: □

\*2 The product that the end of driver model designation has "E" is "Position control type". Detail of model designation, refer to P.16.

\*3 ◇ in number of applicable driver represents the series. For more information about the part number, please refer to P.16.

Torque characteristics (at AC100 V of power voltage <Dotted line represents the torque at 10 % less supply voltage.>)

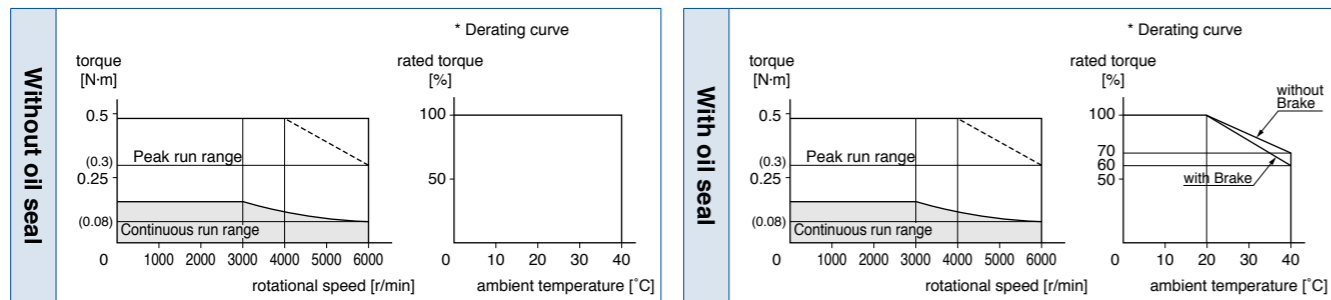

Dimensions

<Without Brake, Cable direction to output shaft>

Mass: 0.31 kg

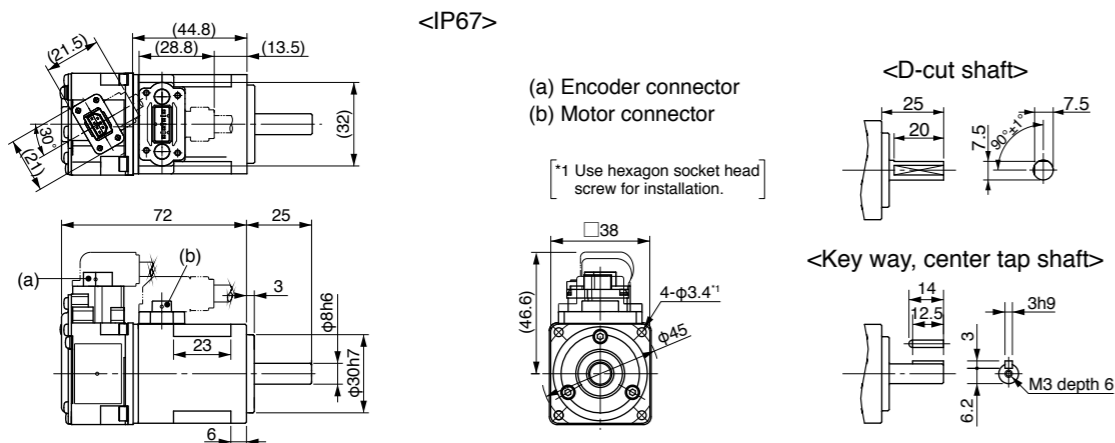

\* For the dimensions with brake, refer to the right page.

[Unit: mm]

<Cautions> Reduce the moment of inertia ratio if high speed response operation is required. Dimensions are subject to change without notice. Contact us or a dealer for the latest information. Read the Instruction Manual carefully and understand all precautions and remarks before using the products.

Specifications

		AC200 V	
Motor model *1	IP65	-	-
	IP67	MSME5AZG1□	MSME5AZS1□
Applicable driver *2	Model No. A5II, A5 series	MAD◇T1505	
	A5IE, A5E series	MAD◇T1505E	-
Frame symbol		A-frame	
Power supply capacity (kVA)		0.5	
Rated output (W)		50	
Rated torque (N·m)		0.16	
Momentary Max. peak torque (N·m)		0.48	
Rated current (A(rms))		1.1	
Max. current (A(o-p))		4.7	
Regenerative brake frequency (times/min) Note1	Without option	No limit Note2	
	DV0P4280	No limit Note2	
Rated rotational speed (r/min)		3000	
Max. rotational speed (r/min)		6000	
Moment of inertia of rotor ( $\times 10^{-4}$ kg·m <sup>2</sup> )	Without brake	0.025	
	With brake	0.027	
Recommended moment of inertia ratio of the load and the rotor Note3		30 times or less	
Rotary encoder specifications Note5	20-bit Incremental		17-bit Absolute
	Resolution per single turn	1,048,576	131,072

• Brake specifications (For details, refer to P.183)

(This brake will be released when it is energized.)  
(Do not use this for braking the motor in motion.)

Static friction torque (N·m)	0.29 or more
Engaging time (ms)	35 or less
Releasing time (ms) Note4	20 or less
Exciting current (DC) (A)	0.3
Releasing voltage (DC) (V)	1 or more
Exciting voltage (DC) (V)	24±1.2

• Permissible load (For details, refer to P.183)

During assembly	Radial load P-direction (N)	147
	Thrust load A-direction (N)	88
	Thrust load B-direction (N)	117.6
During operation	Radial load P-direction (N)	68.6
	Thrust load A, B-direction (N)	58.8

• For details of Note 1 to Note 5, refer to P.182, 183.

• Dimensions of Driver, refer to P.42.

\*1 Motor specifications: □

\*2 The product that the end of driver model designation has "E" is "Position control type". Detail of model designation, refer to P.16.

\*3 ◇ in number of applicable driver represents the series. For more information about the part number, please refer to P.16.

Torque characteristics (at AC200V of power voltage)

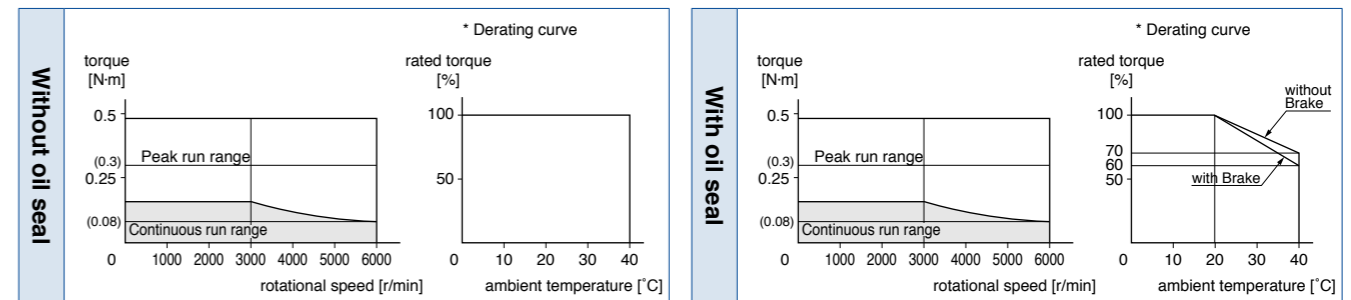

Dimensions

<With Brake, Cable direction to output shaft>

Mass: 0.51 kg

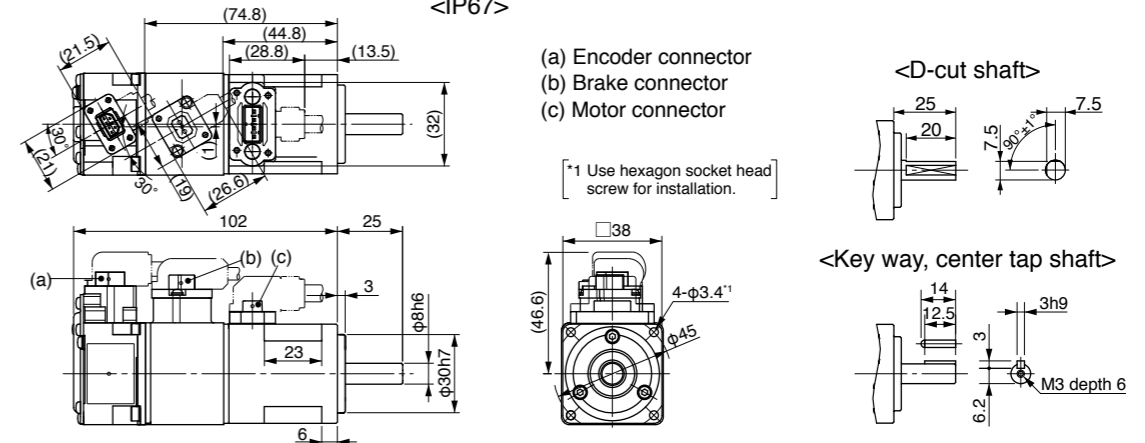

\* For the dimensions without brake, refer to the left page.

[Unit: mm]

<Cautions> Reduce the moment of inertia ratio if high speed response operation is required. Dimensions are subject to change without notice. Contact us or a dealer for the latest information. Read the Instruction Manual carefully and understand all precautions and remarks before using the products.

**Specifications**

		AC100 V	
Motor model *1	IP65	-	-
	IP67	MSME011G1□	MSME011S1□
Applicable driver *2	Model No.	A5II, A5 series	MAD◇T1107
		A5IE, A5E series	MAD◇T1107E
	Frame symbol	A-frame	
Power supply capacity (kVA)	0.4		
Rated output (W)	100		
Rated torque (N·m)	0.32		
Momentary Max. peak torque (N·m)	0.95		
Rated current (A(rms))	1.6		
Max. current (A(o-p))	6.9		
Regenerative brake frequency (times/min) Note)1	Without option	No limit Note)2	
	DV0P4280	No limit Note)2	
Rated rotational speed (r/min)	3000		
Max. rotational speed (r/min)	6000		
Moment of inertia of rotor ( $\times 10^{-4}$ kg·m <sup>2</sup> )	Without brake	0.051	
	With brake	0.054	
Recommended moment of inertia ratio of the load and the rotor Note)3	30 times or less		
Rotary encoder specifications Note)5	20-bit Incremental	17-bit Absolute	
	Resolution per single turn	1,048,576	131,072

**• Brake specifications** (For details, refer to P.183)  
(This brake will be released when it is energized.)  
(Do not use this for braking the motor in motion.)

Static friction torque (N·m)	0.29 or more
Engaging time (ms)	35 or less
Releasing time (ms) Note)4	20 or less
Exciting current (DC) (A)	0.3
Releasing voltage (DC) (V)	1 or more
Exciting voltage (DC) (V)	24±1.2

**• Permissible load** (For details, refer to P.183)

During assembly	Radial load P-direction (N)	147
	Thrust load A-direction (N)	88
	Thrust load B-direction (N)	117.6
During operation	Radial load P-direction (N)	68.6
	Thrust load A, B-direction (N)	58.8

• For details of Note 1 to Note 5, refer to P.182, 183.  
• Dimensions of Driver, refer to P.42.

- \*1 Motor specifications: □
- \*2 The product that the end of driver model designation has "E" is "Position control type". Detail of model designation, refer to P.16.
- \*3 ◇ in number of applicable driver represents the series. For more information about the part number, please refer to P.16.

**Torque characteristics (at AC100 V of power voltage <Dotted line represents the torque at 10 % less supply voltage.>)**

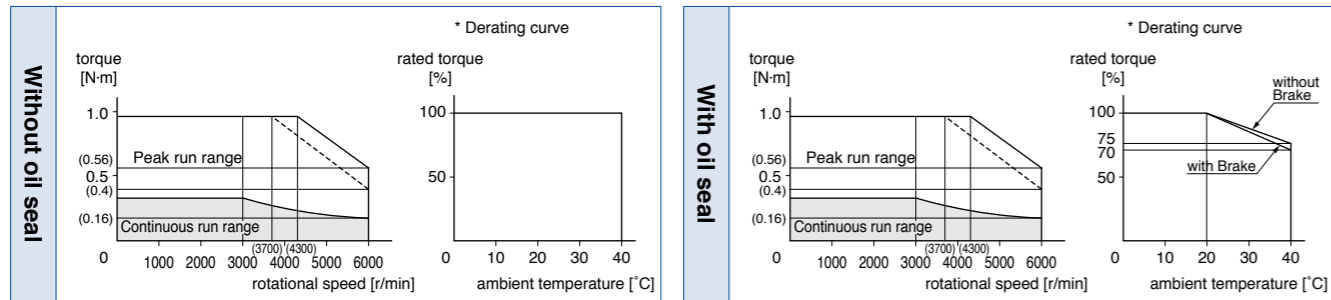

**Dimensions**

<Without Brake, Cable direction to output shaft>

Mass: 0.46 kg

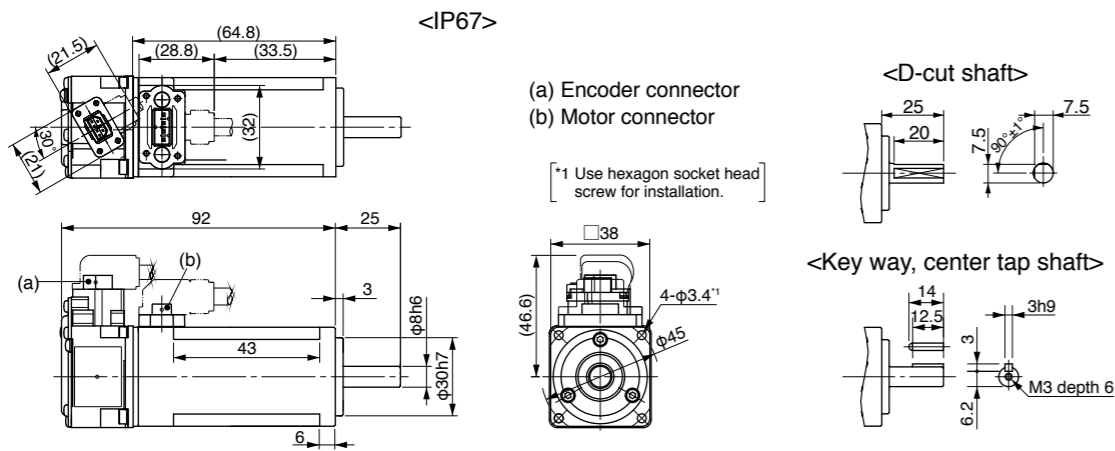

\* For the dimensions with brake, refer to the right page.

[Unit: mm]

**<Cautions>** Reduce the moment of inertia ratio if high speed response operation is required. Dimensions are subject to change without notice. Contact us or a dealer for the latest information. Read the Instruction Manual carefully and understand all precautions and remarks before using the products.

**Specifications**

		AC200 V	
Motor model *1	IP65	-	-
	IP67	MSME012G1□	MSME012S1□
Applicable driver *2	Model No.	A5II, A5 series	MAD◇T1505
		A5IE, A5E series	MAD◇T1505E
	Frame symbol	A-frame	
Power supply capacity (kVA)	0.5		
Rated output (W)	100		
Rated torque (N·m)	0.32		
Momentary Max. peak torque (N·m)	0.95		
Rated current (A(rms))	1.1		
Max. current (A(o-p))	4.7		
Regenerative brake frequency (times/min) Note)1	Without option	No limit Note)2	
	DV0P4280	No limit Note)2	
Rated rotational speed (r/min)	3000		
Max. rotational speed (r/min)	6000		
Moment of inertia of rotor ( $\times 10^{-4}$ kg·m <sup>2</sup> )	Without brake	0.051	
	With brake	0.054	
Recommended moment of inertia ratio of the load and the rotor Note)3	30 times or less		
Rotary encoder specifications Note)5	20-bit Incremental	17-bit Absolute	
	Resolution per single turn	1,048,576	131,072

**• Brake specifications** (For details, refer to P.183)  
(This brake will be released when it is energized.)  
(Do not use this for braking the motor in motion.)

Static friction torque (N·m)	0.29 or more
Engaging time (ms)	35 or less
Releasing time (ms) Note)4	20 or less
Exciting current (DC) (A)	0.3
Releasing voltage (DC) (V)	1 or more
Exciting voltage (DC) (V)	24±1.2

**• Permissible load** (For details, refer to P.183)

During assembly	Radial load P-direction (N)	147
	Thrust load A-direction (N)	88
	Thrust load B-direction (N)	117.6
During operation	Radial load P-direction (N)	68.6
	Thrust load A, B-direction (N)	58.8

• For details of Note 1 to Note 5, refer to P.182, 183.  
• Dimensions of Driver, refer to P.42.

- \*1 Motor specifications: □
- \*2 The product that the end of driver model designation has "E" is "Position control type". Detail of model designation, refer to P.16.
- \*3 ◇ in number of applicable driver represents the series. For more information about the part number, please refer to P.16.

**Torque characteristics (at AC200 V of power voltage <Dotted line represents the torque at 10 % less supply voltage.>)**

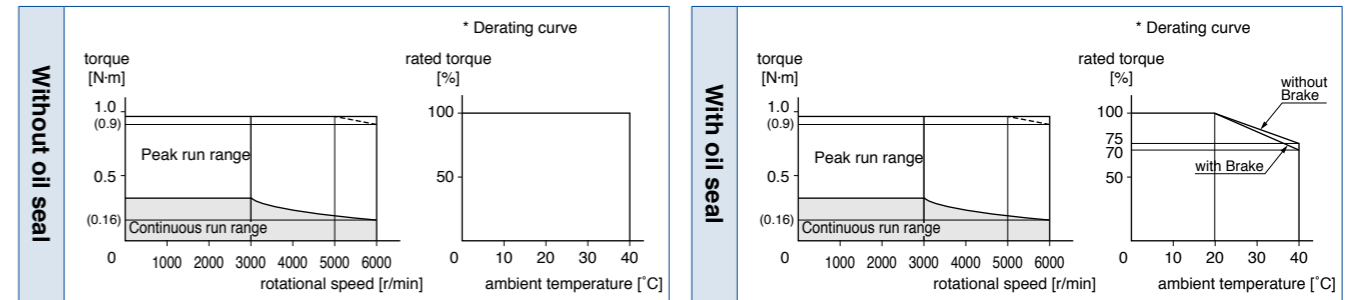

**Dimensions**

<With Brake, Cable direction to output shaft>

Mass: 0.66 kg

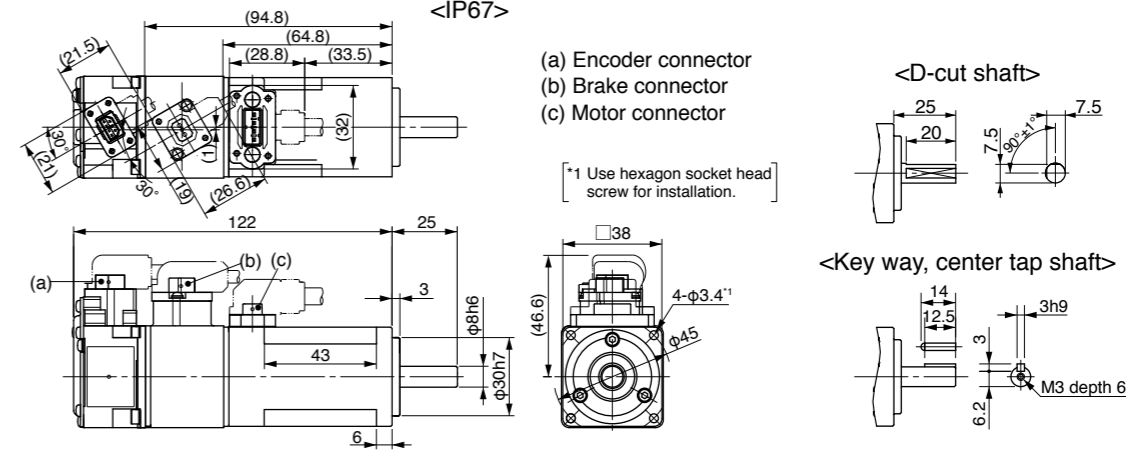

\* For the dimensions without brake, refer to the left page.

[Unit: mm]

**<Cautions>** Reduce the moment of inertia ratio if high speed response operation is required. Dimensions are subject to change without notice. Contact us or a dealer for the latest information. Read the Instruction Manual carefully and understand all precautions and remarks before using the products.

Specifications

		AC100 V	
Motor model *1	IP65	-	-
	IP67	MSME021G1□	MSME021S1□
Applicable driver *2	Model No. A5II, A5 series	MBD◇T2110	
	A5IE, A5E series	MBD◇T2110E	-
Frame symbol		B-frame	
Power supply capacity (kVA)		0.5	
Rated output (W)		200	
Rated torque (N·m)		0.64	
Momentary Max. peak torque (N·m)		1.91	
Rated current (A(rms))		2.5	
Max. current (A(o-p))		10.6	
Regenerative brake frequency (times/min) Note1	Without option	No limit Note2	
	DV0P4283	No limit Note2	
Rated rotational speed (r/min)		3000	
Max. rotational speed (r/min)		6000	
Moment of inertia of rotor (×10 <sup>-4</sup> kg·m <sup>2</sup> )	Without brake	0.14	
	With brake	0.16	
Recommended moment of inertia ratio of the load and the rotor Note3		30 times or less	
Rotary encoder specifications Note5	20-bit Incremental		17-bit Absolute
	Resolution per single turn	1,048,576	131,072

• Brake specifications (For details, refer to P.183)

(This brake will be released when it is energized.)  
(Do not use this for braking the motor in motion.)

Static friction torque (N·m)	1.27 or more
Engaging time (ms)	50 or less
Releasing time (ms) Note4	15 or less
Exciting current (DC) (A)	0.36
Releasing voltage (DC) (V)	1 or more
Exciting voltage (DC) (V)	24±1.2

• Permissible load (For details, refer to P.183)

During assembly	Radial load P-direction (N)	392
	Thrust load A-direction (N)	147
	Thrust load B-direction (N)	196
During operation	Radial load P-direction (N)	245
	Thrust load A, B-direction (N)	98

• For details of Note 1 to Note 5, refer to P.182, 183.

• Dimensions of Driver, refer to P.42.

\*1 Motor specifications: □

\*2 The product that the end of driver model designation has "E" is "Position control type". Detail of model designation, refer to P.16.

\*3 ◇ in number of applicable driver represents the series. For more information about the part number, please refer to P.16.

Torque characteristics (at AC100 V of power voltage <Dotted line represents the torque at 10 % less supply voltage.>)

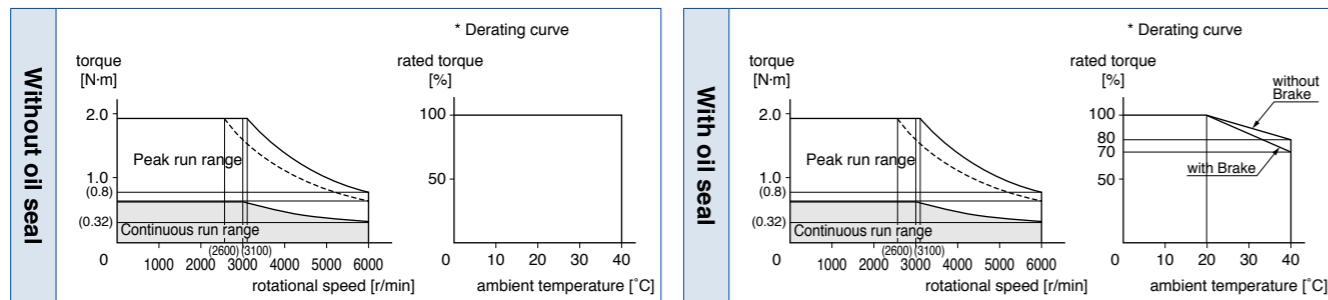

Dimensions

<Without Brake, Cable direction to output shaft>

Mass: 0.78 kg

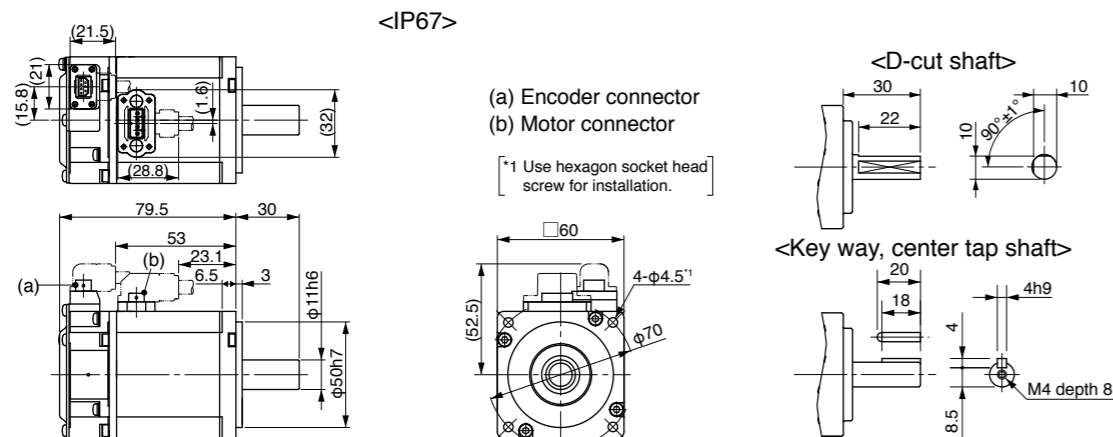

\* For the dimensions with brake, refer to the right page.

[Unit: mm]

<Cautions> Reduce the moment of inertia ratio if high speed response operation is required. Dimensions are subject to change without notice. Contact us or a dealer for the latest information. Read the Instruction Manual carefully and understand all precautions and remarks before using the products.

Specifications

		AC200 V	
Motor model *1	IP65	-	-
	IP67	MSME022G1□	MSME022S1□
Applicable driver *2	Model No. A5II, A5 series	MAD◇T1507	
	A5IE, A5E series	MAD◇T1507E	-
Frame symbol		A-frame	
Power supply capacity (kVA)		0.5	
Rated output (W)		200	
Rated torque (N·m)		0.64	
Momentary Max. peak torque (N·m)		1.91	
Rated current (A(rms))		1.5	
Max. current (A(o-p))		6.5	
Regenerative brake frequency (times/min) Note1	Without option	No limit Note2	
	DV0P4283	No limit Note2	
Rated rotational speed (r/min)		3000	
Max. rotational speed (r/min)		6000	
Moment of inertia of rotor (×10 <sup>-4</sup> kg·m <sup>2</sup> )	Without brake	0.14	
	With brake	0.16	
Recommended moment of inertia ratio of the load and the rotor Note3		30 times or less	
Rotary encoder specifications Note5	20-bit Incremental		17-bit Absolute
	Resolution per single turn	1,048,576	131,072

• Brake specifications (For details, refer to P.183)

(This brake will be released when it is energized.)  
(Do not use this for braking the motor in motion.)

Static friction torque (N·m)	1.27 or more
Engaging time (ms)	50 or less
Releasing time (ms) Note4	15 or less
Exciting current (DC) (A)	0.36
Releasing voltage (DC) (V)	1 or more
Exciting voltage (DC) (V)	24±1.2

• Permissible load (For details, refer to P.183)

During assembly	Radial load P-direction (N)	392
	Thrust load A-direction (N)	147
	Thrust load B-direction (N)	196
During operation	Radial load P-direction (N)	245
	Thrust load A, B-direction (N)	98

• For details of Note 1 to Note 5, refer to P.182, 183.

• Dimensions of Driver, refer to P.42.

\*1 Motor specifications: □

\*2 The product that the end of driver model designation has "E" is "Position control type". Detail of model designation, refer to P.16.

\*3 ◇ in number of applicable driver represents the series. For more information about the part number, please refer to P.16.

Torque characteristics (at AC200 V of power voltage <Dotted line represents the torque at 10 % less supply voltage.>)

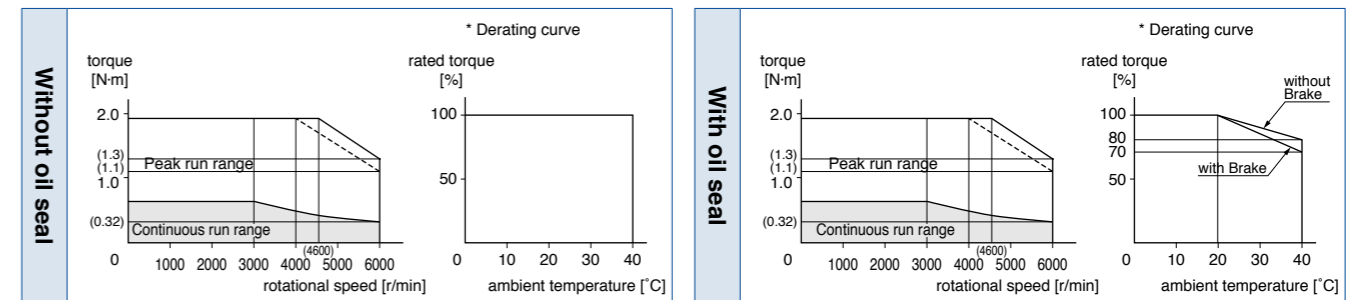

Dimensions

<With Brake, Cable direction to output shaft>

Mass: 1.2 kg

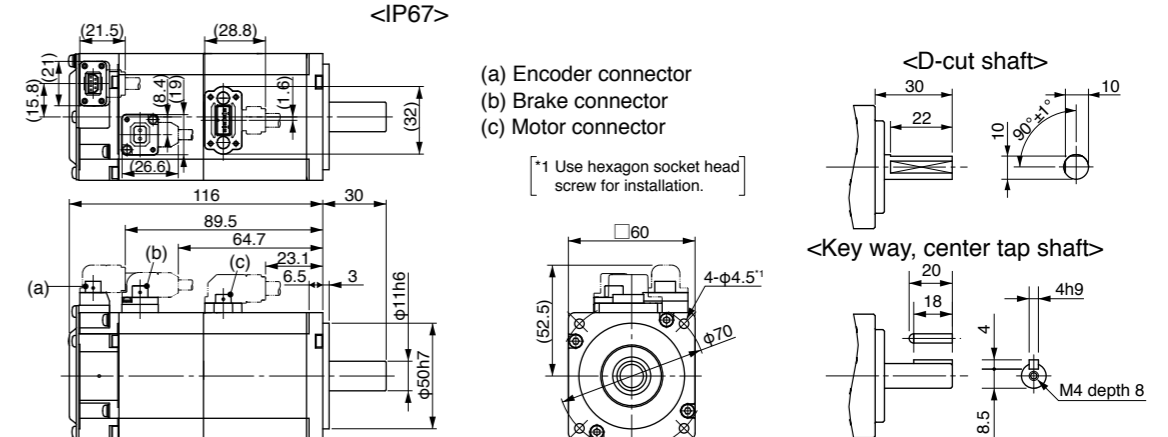

\* For the dimensions without brake, refer to the left page.

[Unit: mm]

<Cautions> Reduce the moment of inertia ratio if high speed response operation is required. Dimensions are subject to change without notice. Contact us or a dealer for the latest information. Read the Instruction Manual carefully and understand all precautions and remarks before using the products.

Specifications

		AC100 V	
Motor model *1	IP65	-	-
	IP67	MSME041G1□	MSME041S1□
Applicable driver *2	Model No. A5II, A5 series	MCD◇T3120	
	A5IE, A5E series	MCD◇T3120E	-
Frame symbol		C-frame	
Power supply capacity (kVA)		0.9	
Rated output (W)		400	
Rated torque (N·m)		1.3	
Momentary Max. peak torque (N·m)		3.8	
Rated current (A(rms))		4.6	
Max. current (A(o-p))		19.5	
Regenerative brake frequency (times/min) Note1	Without option	No limit Note2	
	DV0P4282	No limit Note2	
Rated rotational speed (r/min)		3000	
Max. rotational speed (r/min)		6000	
Moment of inertia of rotor (×10 <sup>-4</sup> kg·m <sup>2</sup> )	Without brake	0.26	
	With brake	0.28	
Recommended moment of inertia ratio of the load and the rotor Note3		30 times or less	
Rotary encoder specifications Note5	20-bit Incremental		17-bit Absolute
	Resolution per single turn	1,048,576	131,072

• **Brake specifications** (For details, refer to P.183)  
 (This brake will be released when it is energized.)  
 (Do not use this for braking the motor in motion.)

Static friction torque (N·m)	1.27 or more
Engaging time (ms)	50 or less
Releasing time (ms) Note4	15 or less
Exciting current (DC) (A)	0.36
Releasing voltage (DC) (V)	1 or more
Exciting voltage (DC) (V)	24±1.2

• **Permissible load** (For details, refer to P.183)

During assembly	Radial load P-direction (N)	392
	Thrust load A-direction (N)	147
	Thrust load B-direction (N)	196
During operation	Radial load P-direction (N)	245
	Thrust load A, B-direction (N)	98

• For details of Note 1 to Note 5, refer to P.182, 183.

• Dimensions of Driver, refer to P.43.

\*1 Motor specifications: □

\*2 The product that the end of driver model designation has "E" is "Position control type". Detail of model designation, refer to P.16.

\*3 ◇ in number of applicable driver represents the series. For more information about the part number, please refer to P.16.

Torque characteristics (at AC100 V of power voltage <Dotted line represents the torque at 10 % less supply voltage.>)

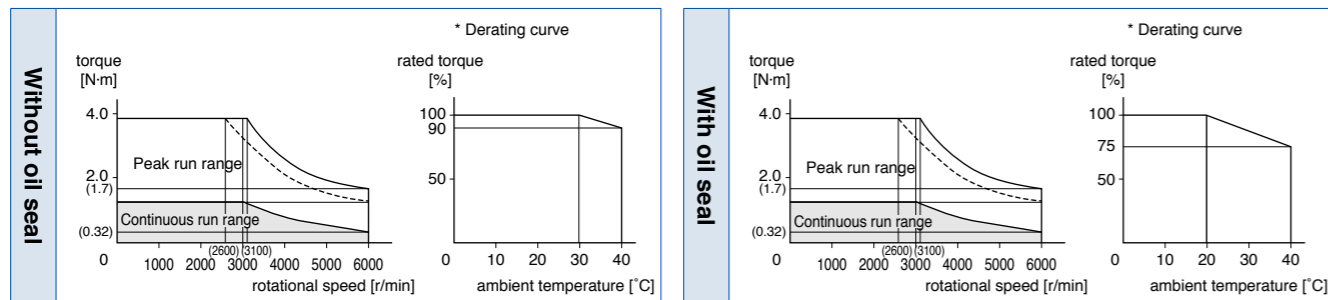

Dimensions

<Without Brake, Cable direction to output shaft>

Mass: 1.2 kg

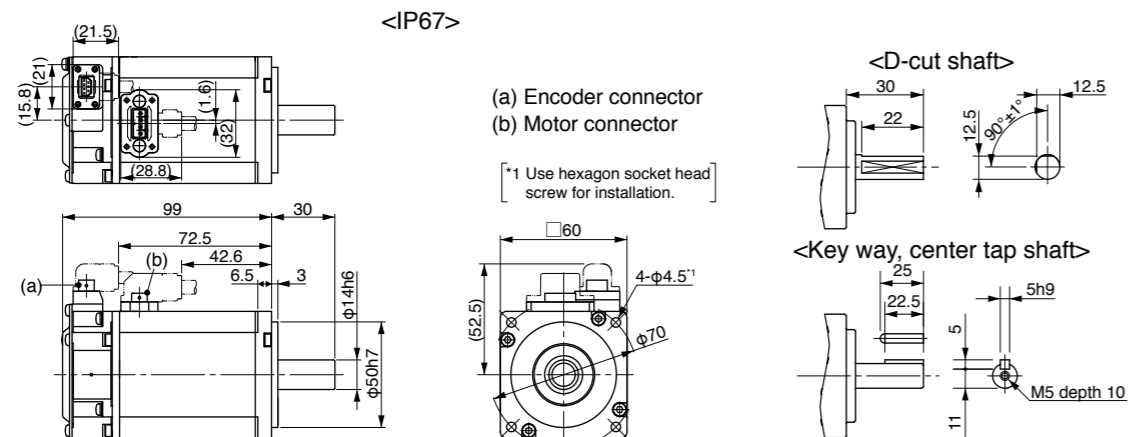

\* For the dimensions with brake, refer to the right page.

[Unit: mm]

<Cautions> Reduce the moment of inertia ratio if high speed response operation is required. Dimensions are subject to change without notice. Contact us or a dealer for the latest information. Read the Instruction Manual carefully and understand all precautions and remarks before using the products.

Specifications

		AC200 V	
Motor model *1	IP65	-	-
	IP67	MSME042G1□	MSME042S1□
Applicable driver *2	Model No. A5II, A5 series	MBD◇T2510	
	A5IE, A5E series	MBD◇T2510E	-
Frame symbol		B-frame	
Power supply capacity (kVA)		0.9	
Rated output (W)		400	
Rated torque (N·m)		1.3	
Momentary Max. peak torque (N·m)		3.8	
Rated current (A(rms))		2.4	
Max. current (A(o-p))		10.2	
Regenerative brake frequency (times/min) Note1	Without option	No limit Note2	
	DV0P4283	No limit Note2	
Rated rotational speed (r/min)		3000	
Max. rotational speed (r/min)		6000	
Moment of inertia of rotor (×10 <sup>-4</sup> kg·m <sup>2</sup> )	Without brake	0.26	
	With brake	0.28	
Recommended moment of inertia ratio of the load and the rotor Note3		30 times or less	
Rotary encoder specifications Note5	20-bit Incremental		17-bit Absolute
	Resolution per single turn	1,048,576	131,072

• **Brake specifications** (For details, refer to P.183)  
 (This brake will be released when it is energized.)  
 (Do not use this for braking the motor in motion.)

Static friction torque (N·m)	1.27 or more
Engaging time (ms)	50 or less
Releasing time (ms) Note4	15 or less
Exciting current (DC) (A)	0.36
Releasing voltage (DC) (V)	1 or more
Exciting voltage (DC) (V)	24±1.2

• **Permissible load** (For details, refer to P.183)

During assembly	Radial load P-direction (N)	392
	Thrust load A-direction (N)	147
	Thrust load B-direction (N)	196
During operation	Radial load P-direction (N)	245
	Thrust load A, B-direction (N)	98

• For details of Note 1 to Note 5, refer to P.182, 183.

• Dimensions of Driver, refer to P.42.

\*1 Motor specifications: □

\*2 The product that the end of driver model designation has "E" is "Position control type". Detail of model designation, refer to P.16.

\*3 ◇ in number of applicable driver represents the series. For more information about the part number, please refer to P.16.

Torque characteristics (at AC200 V of power voltage <Dotted line represents the torque at 10 % less supply voltage.>)

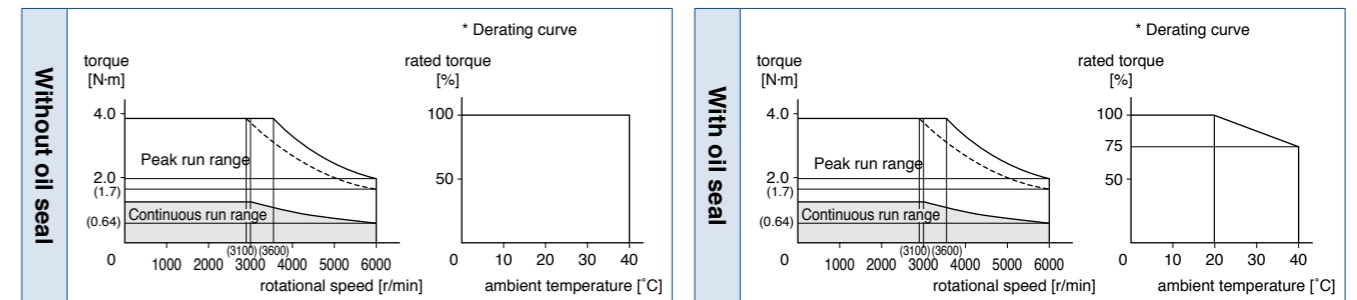

Dimensions

<With Brake, Cable direction to output shaft>

Mass: 1.6 kg

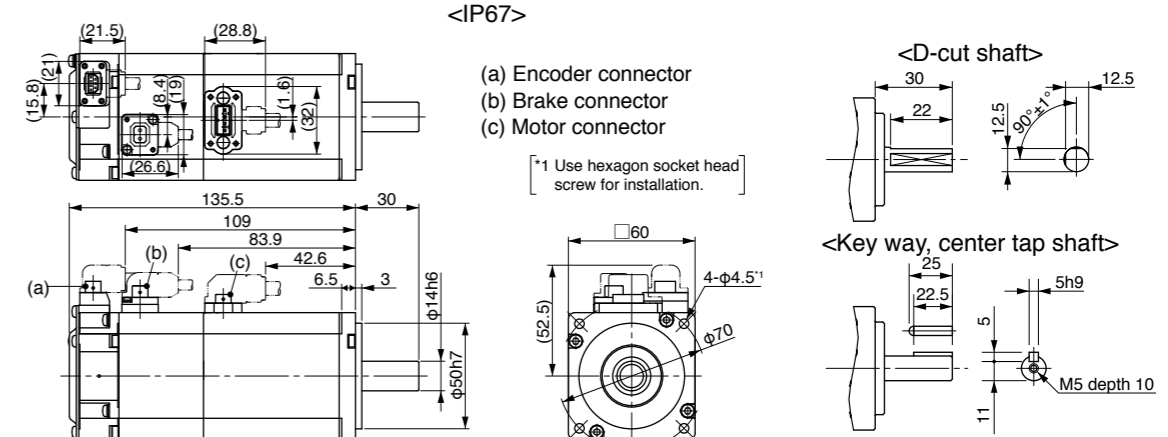

\* For the dimensions without brake, refer to the left page.

[Unit: mm]

<Cautions> Reduce the moment of inertia ratio if high speed response operation is required. Dimensions are subject to change without notice. Contact us or a dealer for the latest information. Read the Instruction Manual carefully and understand all precautions and remarks before using the products.

Specifications

		AC200 V	
Motor model *1	IP65	-	-
	IP67	MSME082G1□	MSME082S1□
Applicable driver *2	Model No. A5II, A5 series	MCD◇T3520	
	A5IE, A5E series	MCD◇T3520E	-
Frame symbol		C-frame	
Power supply capacity (kVA)		1.3	
Rated output (W)		750	
Rated torque (N·m)		2.4	
Momentary Max. peak torque (N·m)		7.1	
Rated current (A(rms))		4.1	
Max. current (A(o-p))		17.4	
Regenerative brake frequency (times/min) Note1	Without option	No limit	Note2
	DV0P4283	No limit	Note2
Rated rotational speed (r/min)		3000	
Max. rotational speed (r/min)		6000	
Moment of inertia of rotor (x10 <sup>-4</sup> kg·m <sup>2</sup> )	Without brake	0.87	
	With brake	0.97	
Recommended moment of inertia ratio of the load and the rotor Note3		20 times or less	
Rotary encoder specifications Note5	20-bit Incremental		17-bit Absolute
	Resolution per single turn	1,048,576	131,072

• **Brake specifications** (For details, refer to P.183)  
 (This brake will be released when it is energized.)  
 (Do not use this for braking the motor in motion.)

Static friction torque (N·m)	2.45 or more
Engaging time (ms)	70 or less
Releasing time (ms) Note4	20 or less
Exciting current (DC) (A)	0.42
Releasing voltage (DC) (V)	1 or more
Exciting voltage (DC) (V)	24±1.2

• **Permissible load** (For details, refer to P.183)

During assembly	Radial load P-direction (N)	686
	Thrust load A-direction (N)	294
	Thrust load B-direction (N)	392
During operation	Radial load P-direction (N)	392
	Thrust load A, B-direction (N)	147

• For details of Note 1 to Note 5, refer to P.182, 183.

• Dimensions of Driver, refer to P.43.

\*1 Motor specifications: □

\*2 The product that the end of driver model designation has "E" is "Position control type". Detail of model designation, refer to P.16.

\*3 ◇ in number of applicable driver represents the series. For more information about the part number, please refer to P.16.

Torque characteristics (at AC200 V of power voltage <Dotted line represents the torque at 10 % less supply voltage.>)

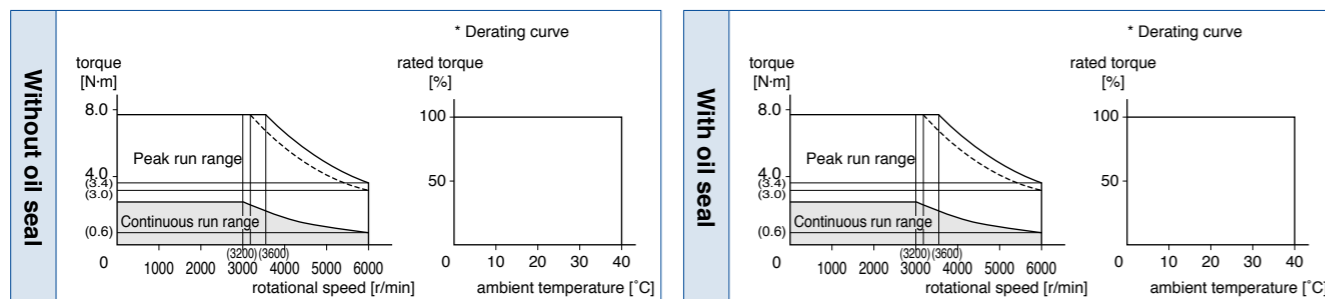

Dimensions

<With Brake, Cable direction to output shaft>

<IP67>

Mass: Without brake/ 2.3 kg  
With brake/ 3.1 kg

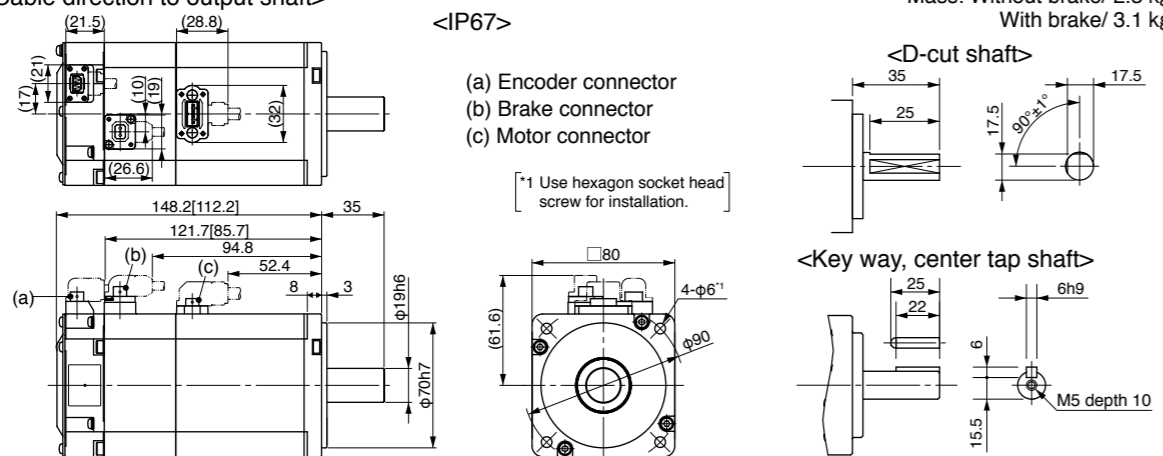

\* Figures in [ ] represent the dimensions without brake.

[Unit: mm]

<Cautions> Reduce the moment of inertia ratio if high speed response operation is required. Dimensions are subject to change without notice. Contact us or a dealer for the latest information. Read the Instruction Manual carefully and understand all precautions and remarks before using the products.

Specifications

		AC200 V	
Motor model *1	IP65	MSME102GC□	MSME102SC□
	IP67	MSME102G1□	MSME102S1□
Applicable driver *2	Model No. A5II, A5 series	MDD◇T5540	
	A5IE, A5E series	MDD◇T5540E	-
Frame symbol		D-frame	
Power supply capacity (kVA)		1.8	
Rated output (W)		1000	
Rated torque (N·m)		3.18	
Momentary Max. peak torque (N·m)		9.55	
Rated current (A(rms))		6.6	
Max. current (A(o-p))		28	
Regenerative brake frequency (times/min) Note1	Without option	No limit	Note2
	DV0P4284	No limit	Note2
Rated rotational speed (r/min)		3000	
Max. rotational speed (r/min)		5000	
Moment of inertia of rotor (x10 <sup>-4</sup> kg·m <sup>2</sup> )	Without brake	2.03	
	With brake	2.35	
Recommended moment of inertia ratio of the load and the rotor Note3		15 times or less	
Rotary encoder specifications Note5	20-bit Incremental		17-bit Absolute
	Resolution per single turn	1,048,576	131,072

• **Brake specifications** (For details, refer to P.183)  
 (This brake will be released when it is energized.)  
 (Do not use this for braking the motor in motion.)

Static friction torque (N·m)	7.8 or more
Engaging time (ms)	50 or less
Releasing time (ms) Note4	15 or less
Exciting current (DC) (A)	0.81±10 %
Releasing voltage (DC) (V)	2 or more
Exciting voltage (DC) (V)	24±2.4

• **Permissible load** (For details, refer to P.183)

During assembly	Radial load P-direction (N)	980
	Thrust load A-direction (N)	588
	Thrust load B-direction (N)	686
During operation	Radial load P-direction (N)	490
	Thrust load A, B-direction (N)	196

• For details of Note 1 to Note 5, refer to P.182, 183.

• Dimensions of Driver, refer to P.43.

\*1 Motor specifications: □

\*2 The product that the end of driver model designation has "E" is "Position control type". Detail of model designation, refer to P.16.

\*3 ◇ in number of applicable driver represents the series. For more information about the part number, please refer to P.16.

Torque characteristics (at AC200 V of power voltage <Dotted line represents the torque at 10 % less supply voltage.>)

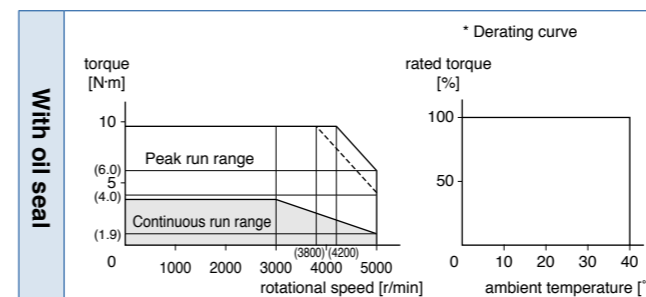

Dimensions

(For IP67 motor, refer to P.137.)

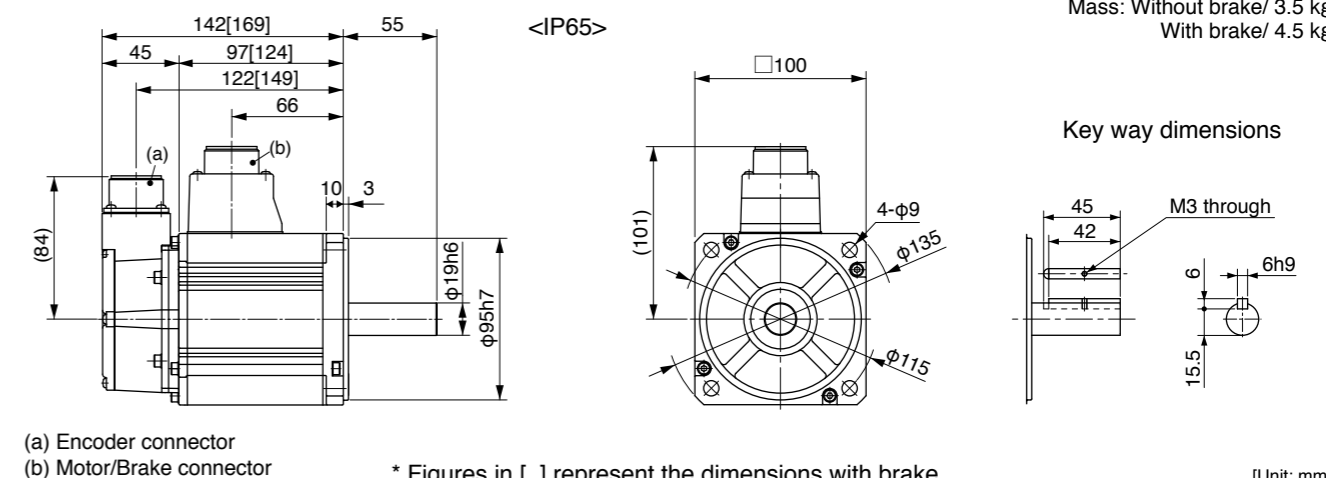

\* Figures in [ ] represent the dimensions with brake.

[Unit: mm]

<Cautions> Reduce the moment of inertia ratio if high speed response operation is required. Dimensions are subject to change without notice. Contact us or a dealer for the latest information. Read the Instruction Manual carefully and understand all precautions and remarks before using the products.

Specifications

		AC200 V	
Motor model *1	IP65	MSME152GC□	MSME152SC□
	IP67	MSME152G1□	MSME152S1□
Applicable driver *2	Model No. A5II, A5 series	MDD◇T5540	
	A5IE, A5E series	MDD◇T5540E	-
Frame symbol		D-frame	
Power supply capacity (kVA)		2.3	
Rated output (W)		1500	
Rated torque (N·m)		4.77	
Momentary Max. peak torque (N·m)		14.3	
Rated current (A(rms))		8.2	
Max. current (A(o-p))		35	
Regenerative brake frequency (times/min) Note1	Without option	No limit Note2	
	DV0P4284	No limit Note2	
Rated rotational speed (r/min)		3000	
Max. rotational speed (r/min)		5000	
Moment of inertia of rotor (×10 <sup>-4</sup> kg·m <sup>2</sup> )	Without brake	2.84	
	With brake	3.17	
Recommended moment of inertia ratio of the load and the rotor Note3		15 times or less	
Rotary encoder specifications Note5	20-bit Incremental		17-bit Absolute
	Resolution per single turn	1,048,576	131,072

• **Brake specifications** (For details, refer to P.183)  
 (This brake will be released when it is energized.)  
 (Do not use this for braking the motor in motion.)

Static friction torque (N·m)	7.8 or more
Engaging time (ms)	50 or less
Releasing time (ms) Note4	15 or less
Exciting current (DC) (A)	0.81±10 %
Releasing voltage (DC) (V)	2 or more
Exciting voltage (DC) (V)	24±2.4

• **Permissible load** (For details, refer to P.183)

During assembly	Radial load P-direction (N)	980
	Thrust load A-direction (N)	588
	Thrust load B-direction (N)	686
During operation	Radial load P-direction (N)	490
	Thrust load A, B-direction (N)	196

• For details of Note 1 to Note 5, refer to P.182, 183.  
 • Dimensions of Driver, refer to P.43.

- \*1 Motor specifications: □
- \*2 The product that the end of driver model designation has "E" is "Position control type". Detail of model designation, refer to P.16.
- \*3 ◇ in number of applicable driver represents the series. For more information about the part number, please refer to P.16.

Torque characteristics (at AC200 V of power voltage <Dotted line represents the torque at 10 % less supply voltage.>)

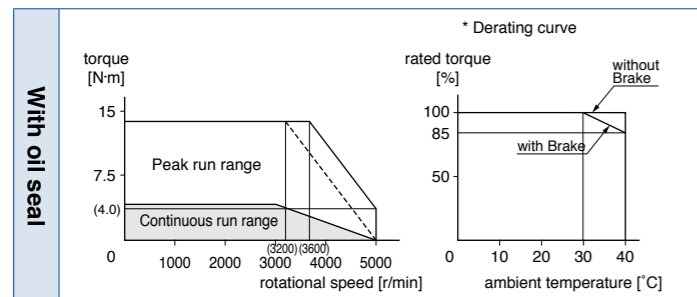

Dimensions

(For IP67 motor, refer to P.137.)

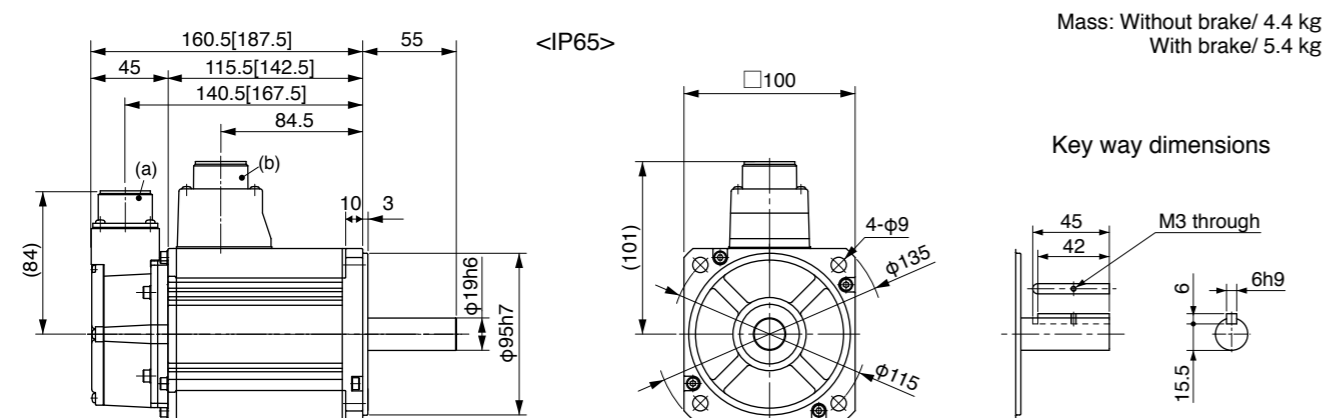

(a) Encoder connector  
 (b) Motor/Brake connector

\* Figures in [ ] represent the dimensions with brake.

[Unit: mm]

<Cautions> Reduce the moment of inertia ratio if high speed response operation is required. Dimensions are subject to change without notice. Contact us or a dealer for the latest information. Read the Instruction Manual carefully and understand all precautions and remarks before using the products.

Specifications

		AC200 V	
Motor model *1	IP65	MSME202GC□	MSME202SC□
	IP67	MSME202G1□	MSME202S1□
Applicable driver *2	Model No. A5II, A5 series	MED◇T7364	
	A5IE, A5E series	MED◇T7364E	-
Frame symbol		E-frame	
Power supply capacity (kVA)		3.3	
Rated output (W)		2000	
Rated torque (N·m)		6.37	
Momentary Max. peak torque (N·m)		19.1	
Rated current (A(rms))		11.3	
Max. current (A(o-p))		48	
Regenerative brake frequency (times/min) Note1	Without option	No limit Note2	
	DV0P4285	No limit Note2	
Rated rotational speed (r/min)		3000	
Max. rotational speed (r/min)		5000	
Moment of inertia of rotor (×10 <sup>-4</sup> kg·m <sup>2</sup> )	Without brake	3.68	
	With brake	4.01	
Recommended moment of inertia ratio of the load and the rotor Note3		15 times or less	
Rotary encoder specifications Note5	20-bit Incremental		17-bit Absolute
	Resolution per single turn	1,048,576	131,072

• **Brake specifications** (For details, refer to P.183)  
 (This brake will be released when it is energized.)  
 (Do not use this for braking the motor in motion.)

Static friction torque (N·m)	7.8 or more
Engaging time (ms)	50 or less
Releasing time (ms) Note4	15 or less
Exciting current (DC) (A)	0.81±10 %
Releasing voltage (DC) (V)	2 or more
Exciting voltage (DC) (V)	24±2.4

• **Permissible load** (For details, refer to P.183)

During assembly	Radial load P-direction (N)	980
	Thrust load A-direction (N)	588
	Thrust load B-direction (N)	686
During operation	Radial load P-direction (N)	490
	Thrust load A, B-direction (N)	196

• For details of Note 1 to Note 5, refer to P.182, 183.  
 • Dimensions of Driver, refer to P.44.

- \*1 Motor specifications: □
- \*2 The product that the end of driver model designation has "E" is "Position control type". Detail of model designation, refer to P.16.
- \*3 ◇ in number of applicable driver represents the series. For more information about the part number, please refer to P.16.

Torque characteristics (at AC200 V of power voltage <Dotted line represents the torque at 10 % less supply voltage.>)

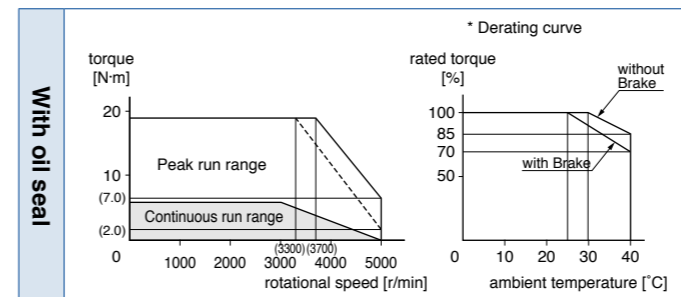

Dimensions

(For IP67 motor, refer to P.137.)

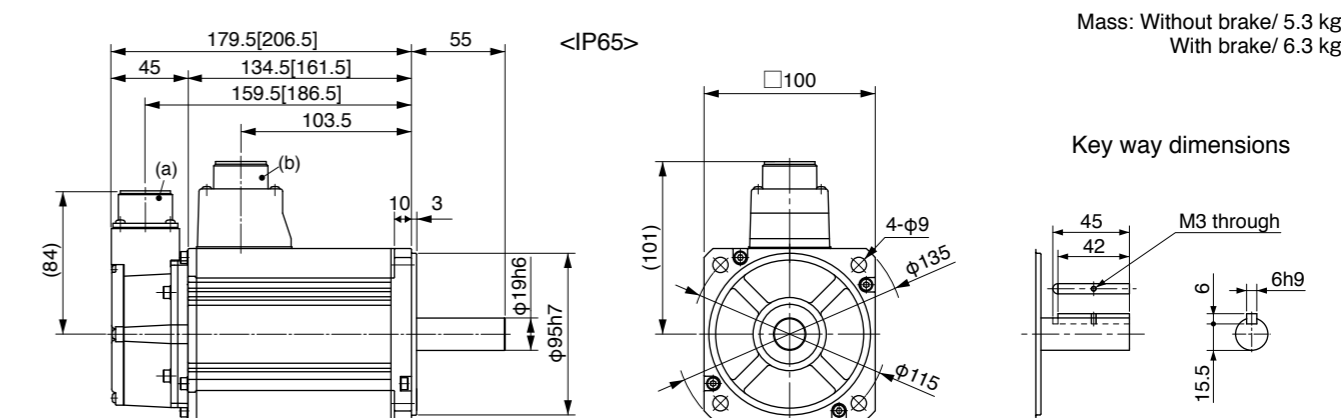

(a) Encoder connector  
 (b) Motor/Brake connector

\* Figures in [ ] represent the dimensions with brake.

[Unit: mm]

<Cautions> Reduce the moment of inertia ratio if high speed response operation is required. Dimensions are subject to change without notice. Contact us or a dealer for the latest information. Read the Instruction Manual carefully and understand all precautions and remarks before using the products.

Specifications

		AC200 V	
Motor model *1	IP65	MSME302GC□	MSME302SC□
	IP67	MSME302G1□	MSME302S1□
Applicable driver *2	Model No. A5II, A5 series	MFD◇TA390	
	A5IE, A5E series	MFD◇TA390E	-
Frame symbol		F-frame	
Power supply capacity (kVA)	4.5		
Rated output (W)	3000		
Rated torque (N·m)	9.55		
Momentary Max. peak torque (N·m)	28.6		
Rated current (A(rms))	18.1		
Max. current (A(o-p))	77		
Regenerative brake frequency (times/min) Note1	Without option	No limit Note2	
	DV0P4285×2	No limit Note2	
Rated rotational speed (r/min)	3000		
Max. rotational speed (r/min)	5000		
Moment of inertia of rotor (×10 <sup>-4</sup> kg·m <sup>2</sup> )	Without brake	6.50	
	With brake	7.85	
Recommended moment of inertia ratio of the load and the rotor Note3	15 times or less		
Rotary encoder specifications Note5	20-bit Incremental	17-bit Absolute	
	Resolution per single turn	1,048,576	131,072

• Brake specifications (For details, refer to P.183)

(This brake will be released when it is energized.)  
(Do not use this for braking the motor in motion.)

Static friction torque (N·m)	11.8 or more
Engaging time (ms)	80 or less
Releasing time (ms) Note4	15 or less
Exciting current (DC) (A)	0.81±10 %
Releasing voltage (DC) (V)	2 or more
Exciting voltage (DC) (V)	24±2.4

• Permissible load (For details, refer to P.183)

During assembly	Radial load P-direction (N)	980
	Thrust load A-direction (N)	588
	Thrust load B-direction (N)	686
During operation	Radial load P-direction (N)	490
	Thrust load A, B-direction (N)	196

• For details of Note 1 to Note 5, refer to P.182, 183.

• Dimensions of Driver, refer to P.45.

\*1 Motor specifications: □

\*2 The product that the end of driver model designation has "E" is "Position control type". Detail of model designation, refer to P.16.

\*3 ◇ in number of applicable driver represents the series. For more information about the part number, please refer to P.16.

Torque characteristics (at AC200 V of power voltage <Dotted line represents the torque at 10 % less supply voltage.>)

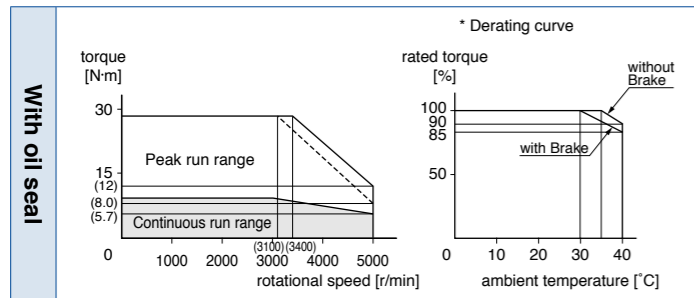

Dimensions

(For IP67 motor, refer to P.137.)

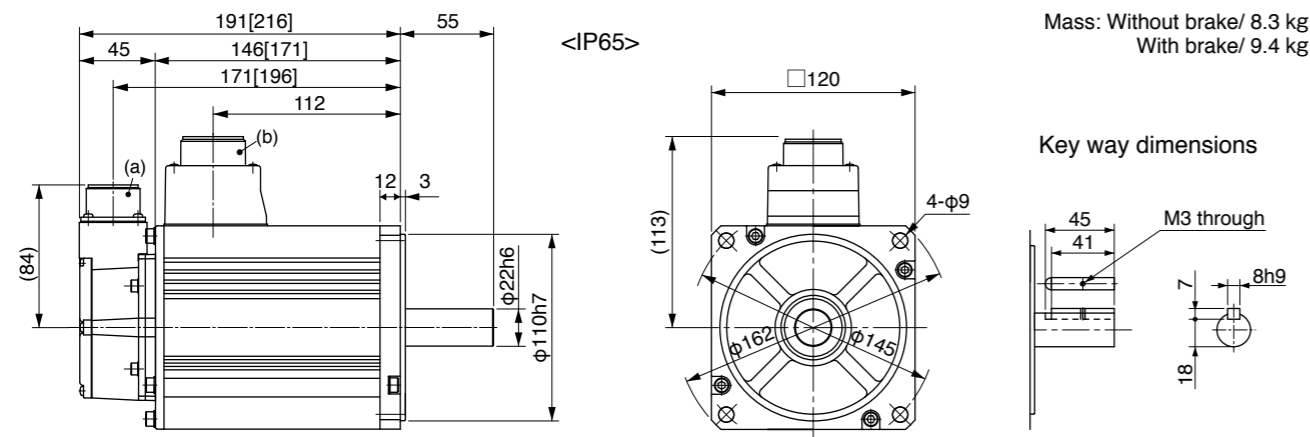

\* Figures in [ ] represent the dimensions with brake.

[Unit: mm]

<Cautions> Reduce the moment of inertia ratio if high speed response operation is required. Dimensions are subject to change without notice. Contact us or a dealer for the latest information. Read the Instruction Manual carefully and understand all precautions and remarks before using the products.

Specifications

		AC200 V	
Motor model *1	IP65	MSME402GC□	MSME402SC□
	IP67	MSME402G1□	MSME402S1□
Applicable driver *2	Model No. A5II, A5 series	MFD◇TB3A2	
	A5IE, A5E series	MFD◇TB3A2E	-
Frame symbol		F-frame	
Power supply capacity (kVA)	6.0		
Rated output (W)	4000		
Rated torque (N·m)	12.7		
Momentary Max. peak torque (N·m)	38.2		
Rated current (A(rms))	19.6		
Max. current (A(o-p))	83		
Regenerative brake frequency (times/min) Note1	Without option	No limit Note2	
	DV0P4285×2	No limit Note2	
Rated rotational speed (r/min)	3000		
Max. rotational speed (r/min)	4500		
Moment of inertia of rotor (×10 <sup>-4</sup> kg·m <sup>2</sup> )	Without brake	12.9	
	With brake	14.2	
Recommended moment of inertia ratio of the load and the rotor Note3	15 times or less		
Rotary encoder specifications Note5	20-bit Incremental	17-bit Absolute	
	Resolution per single turn	1,048,576	131,072

• Brake specifications (For details, refer to P.183)

(This brake will be released when it is energized.)  
(Do not use this for braking the motor in motion.)

Static friction torque (N·m)	16.2 or more
Engaging time (ms)	110 or less
Releasing time (ms) Note4	50 or less
Exciting current (DC) (A)	0.90±10 %
Releasing voltage (DC) (V)	2 or more
Exciting voltage (DC) (V)	24±2.4

• Permissible load (For details, refer to P.183)

During assembly	Radial load P-direction (N)	980
	Thrust load A-direction (N)	588
	Thrust load B-direction (N)	686
During operation	Radial load P-direction (N)	784
	Thrust load A, B-direction (N)	343

• For details of Note 1 to Note 5, refer to P.182, 183.

• Dimensions of Driver, refer to P.45.

\*1 Motor specifications: □

\*2 The product that the end of driver model designation has "E" is "Position control type". Detail of model designation, refer to P.16.

\*3 ◇ in number of applicable driver represents the series. For more information about the part number, please refer to P.16.

Torque characteristics (at AC200 V of power voltage <Dotted line represents the torque at 10 % less supply voltage.>)

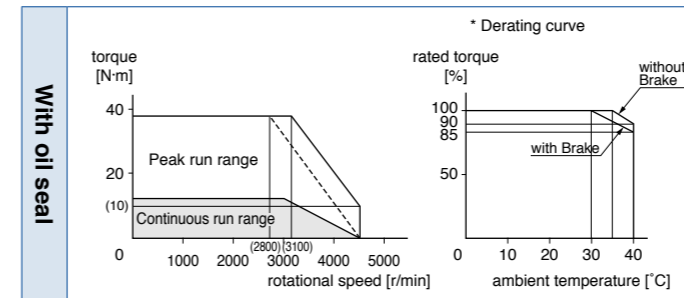

Dimensions

(For IP67 motor, refer to P.137.)

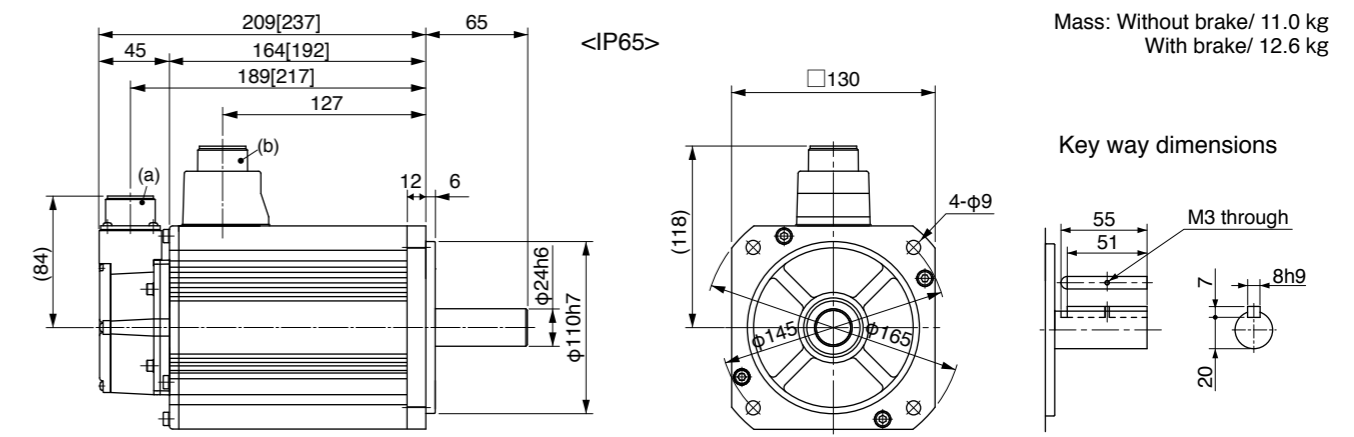

\* Figures in [ ] represent the dimensions with brake.

[Unit: mm]

<Cautions> Reduce the moment of inertia ratio if high speed response operation is required. Dimensions are subject to change without notice. Contact us or a dealer for the latest information. Read the Instruction Manual carefully and understand all precautions and remarks before using the products.



Specifications

		AC200 V	
Motor model *1	IP65	MSME502GC□	MSME502SC□
	IP67	MSME502G1□	MSME502S1□
Applicable driver *2	Model No. A5II, A5 series	MFD◇TB3A2	
	A5IE, A5E series	MFD◇TB3A2E	-
Frame symbol		F-frame	
Power supply capacity (kVA)	7.5		
Rated output (W)	5000		
Rated torque (N·m)	15.9		
Momentary Max. peak torque (N·m)	47.7		
Rated current (A(rms))	24.0		
Max. current (A(o-p))	102		
Regenerative brake frequency (times/min) Note1	Without option	357	
	DV0P4285×2	No limit Note2	
Rated rotational speed (r/min)	3000		
Max. rotational speed (r/min)	4500		
Moment of inertia of rotor (×10 <sup>-4</sup> kg·m <sup>2</sup> )	Without brake	17.4	
	With brake	18.6	
Recommended moment of inertia ratio of the load and the rotor Note3	15 times or less		
Rotary encoder specifications Note5	20-bit Incremental	17-bit Absolute	
	Resolution per single turn	1,048,576	131,072

• Brake specifications (For details, refer to P.183)

(This brake will be released when it is energized.)  
(Do not use this for braking the motor in motion.)

Static friction torque (N·m)	16.2 or more
Engaging time (ms)	110 or less
Releasing time (ms) Note4	50 or less
Exciting current (DC) (A)	0.90±10 %
Releasing voltage (DC) (V)	2 or more
Exciting voltage (DC) (V)	24±2.4

• Permissible load (For details, refer to P.183)

During assembly	Radial load P-direction (N)	980
	Thrust load A-direction (N)	588
	Thrust load B-direction (N)	686
During operation	Radial load P-direction (N)	784
	Thrust load A, B-direction (N)	343

• For details of Note 1 to Note 5, refer to P.182, 183.

• Dimensions of Driver, refer to P.45.

\*1 Motor specifications: □

\*2 The product that the end of driver model designation has "E" is "Position control type". Detail of model designation, refer to P.16.

\*3 ◇ in number of applicable driver represents the series. For more information about the part number, please refer to P.16.

Torque characteristics (at AC200 V of power voltage <Dotted line represents the torque at 10 % less supply voltage.>)

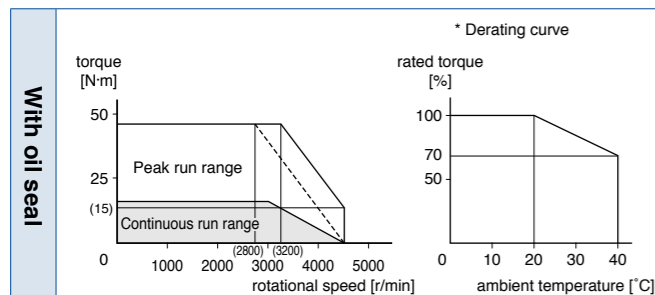

Dimensions

(For IP67 motor, refer to P.138.)

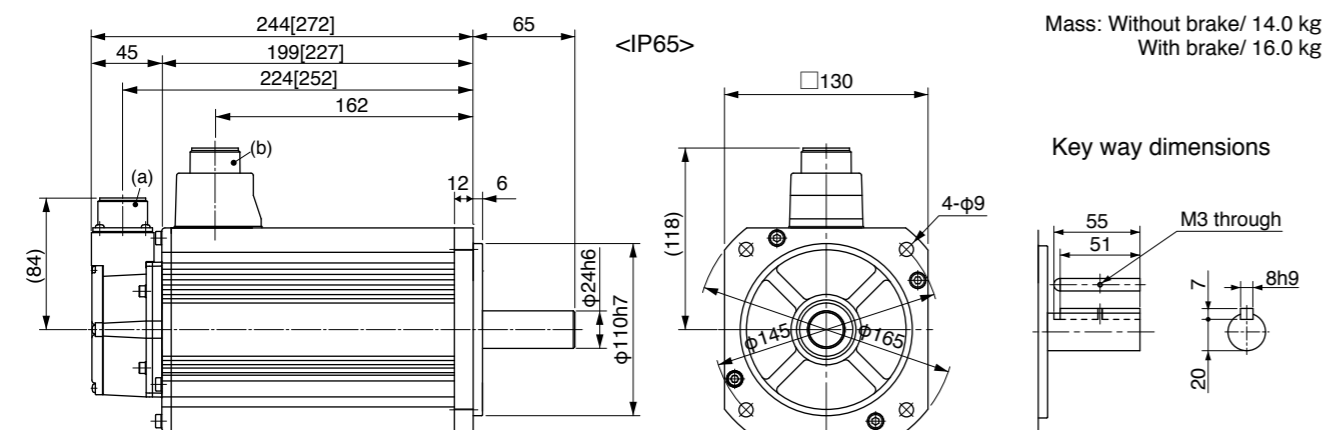

(a) Encoder connector  
(b) Motor/Brake connector

\* Figures in [ ] represent the dimensions with brake.

[Unit: mm]

<Cautions> Reduce the moment of inertia ratio if high speed response operation is required. Dimensions are subject to change without notice. Contact us or a dealer for the latest information. Read the Instruction Manual carefully and understand all precautions and remarks before using the products.

Specifications

		AC200 V	
Motor model *1	IP65	MDME102GC□	MDME102SC□
	IP67	MDME102G1□	MDME102S1□
Applicable driver *2	Model No. A5II, A5 series	MDD◇T3530	
	A5IE, A5E series	MDD◇T3530E	-
Frame symbol		D-frame	
Power supply capacity (kVA)	1.8		
Rated output (W)	1000		
Rated torque (N·m)	4.77		
Momentary Max. peak torque (N·m)	14.3		
Rated current (A(rms))	5.7		
Max. current (A(o-p))	24		
Regenerative brake frequency (times/min) Note1	Without option	No limit Note2	
	DV0P4284	No limit Note2	
Rated rotational speed (r/min)	2000		
Max. rotational speed (r/min)	3000		
Moment of inertia of rotor (×10 <sup>-4</sup> kg·m <sup>2</sup> )	Without brake	4.60	
	With brake	5.90	
Recommended moment of inertia ratio of the load and the rotor Note3	10 times or less		
Rotary encoder specifications Note5	20-bit Incremental	17-bit Absolute	
	Resolution per single turn	1,048,576	131,072

• Brake specifications (For details, refer to P.183)

(This brake will be released when it is energized.)  
(Do not use this for braking the motor in motion.)

Static friction torque (N·m)	4.9 or more
Engaging time (ms)	80 or less
Releasing time (ms) Note4	70 or less
Exciting current (DC) (A)	0.59±10 %
Releasing voltage (DC) (V)	2 or more
Exciting voltage (DC) (V)	24±2.4

• Permissible load (For details, refer to P.183)

During assembly	Radial load P-direction (N)	980
	Thrust load A-direction (N)	588
	Thrust load B-direction (N)	686
During operation	Radial load P-direction (N)	490
	Thrust load A, B-direction (N)	196

• For details of Note 1 to Note 5, refer to P.182, 183.

• Dimensions of Driver, refer to P.43.

\*1 Motor specifications: □

\*2 The product that the end of driver model designation has "E" is "Position control type". Detail of model designation, refer to P.16.

\*3 ◇ in number of applicable driver represents the series. For more information about the part number, please refer to P.16.

Torque characteristics (at AC200 V of power voltage <Dotted line represents the torque at 10 % less supply voltage.>)

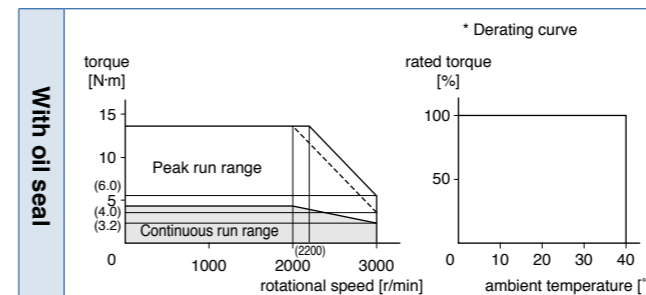

Dimensions

(For IP67 motor, refer to P.138.)

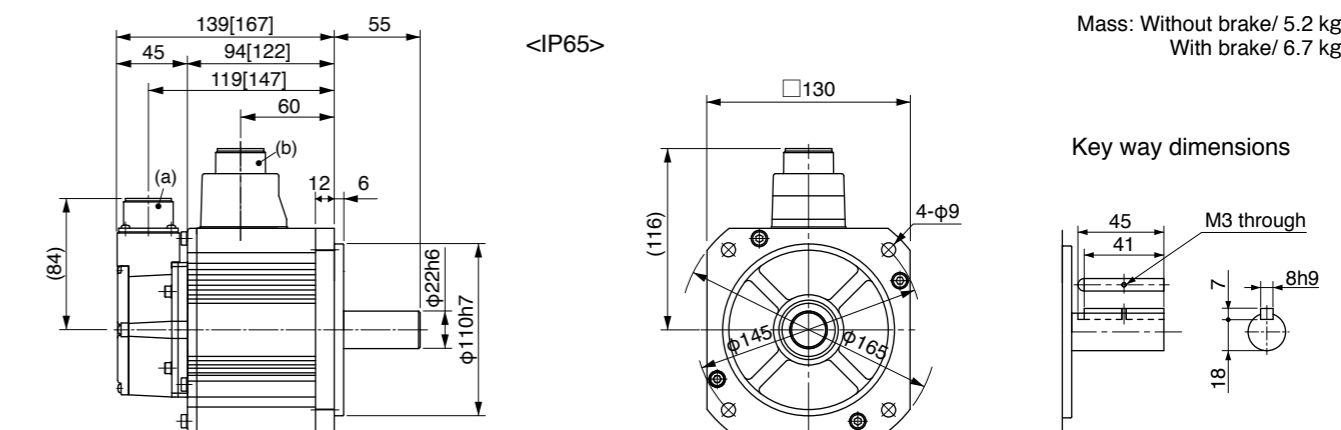

(a) Encoder connector  
(b) Motor/Brake connector

\* Figures in [ ] represent the dimensions with brake.

[Unit: mm]

<Cautions> Reduce the moment of inertia ratio if high speed response operation is required. Dimensions are subject to change without notice. Contact us or a dealer for the latest information. Read the Instruction Manual carefully and understand all precautions and remarks before using the products.

Specifications

		AC200 V	
Motor model *1	IP65	MDME152GC□	MDME152SC□
	IP67	MDME152G1□	MDME152S1□
Applicable driver *2	Model No. A5II, A5 series	MDD◇T5540	
	A5IE, A5E series	MDD◇T5540E	-
Frame symbol		D-frame	
Power supply capacity (kVA)		2.3	
Rated output (W)		1500	
Rated torque (N·m)		7.16	
Momentary Max. peak torque (N·m)		21.5	
Rated current (A(rms))		9.4	
Max. current (A(o-p))		40	
Regenerative brake frequency (times/min) Note1	Without option	No limit Note2	
	DV0P4284	No limit Note2	
Rated rotational speed (r/min)		2000	
Max. rotational speed (r/min)		3000	
Moment of inertia of rotor (×10 <sup>-4</sup> kg·m <sup>2</sup> )	Without brake	6.70	
	With brake	7.99	
Recommended moment of inertia ratio of the load and the rotor Note3		10 times or less	
Rotary encoder specifications Note5	20-bit Incremental		17-bit Absolute
	Resolution per single turn	1,048,576	131,072

• **Brake specifications** (For details, refer to P.183)  
 (This brake will be released when it is energized.)  
 (Do not use this for braking the motor in motion.)

Static friction torque (N·m)	13.7 or more
Engaging time (ms)	100 or less
Releasing time (ms) Note4	50 or less
Exciting current (DC) (A)	0.79±10 %
Releasing voltage (DC) (V)	2 or more
Exciting voltage (DC) (V)	24±2.4

• **Permissible load** (For details, refer to P.183)

During assembly	Radial load P-direction (N)	980
	Thrust load A-direction (N)	588
	Thrust load B-direction (N)	686
During operation	Radial load P-direction (N)	490
	Thrust load A, B-direction (N)	196

• For details of Note 1 to Note 5, refer to P.182, 183.

• Dimensions of Driver, refer to P.43.

\*1 Motor specifications: □

\*2 The product that the end of driver model designation has "E" is "Position control type". Detail of model designation, refer to P.16.

\*3 ◇ in number of applicable driver represents the series. For more information about the part number, please refer to P.16.

Torque characteristics (at AC200 V of power voltage <Dotted line represents the torque at 10 % less supply voltage.>)

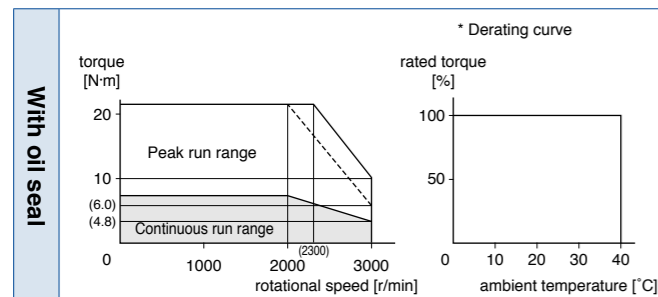

Dimensions

(For IP67 motor, refer to P.138.)

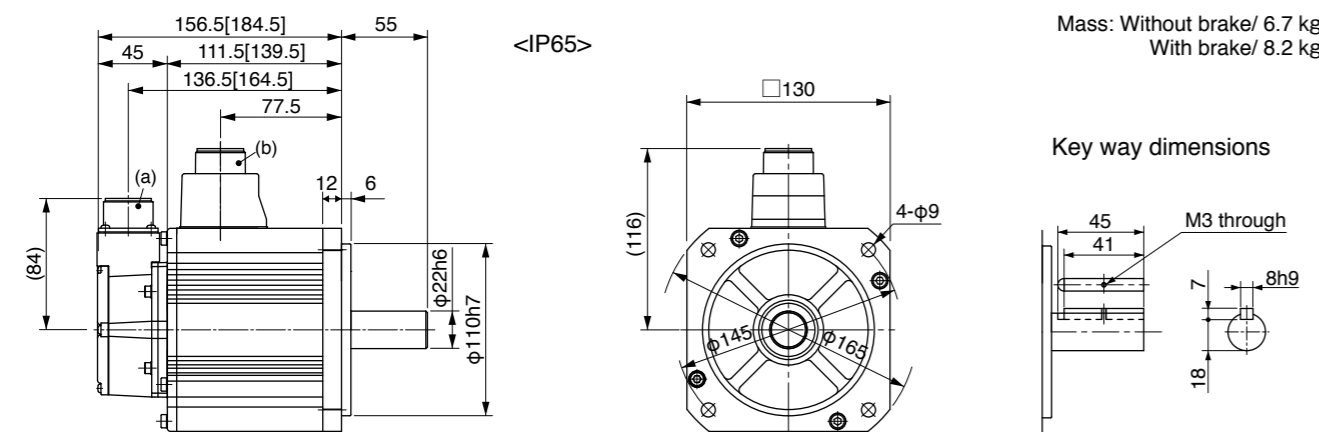

(a) Encoder connector  
 (b) Motor/Brake connector

\* Figures in [ ] represent the dimensions with brake.

[Unit: mm]

<Cautions> Reduce the moment of inertia ratio if high speed response operation is required. Dimensions are subject to change without notice. Contact us or a dealer for the latest information. Read the Instruction Manual carefully and understand all precautions and remarks before using the products.

Specifications

		AC200 V	
Motor model *1	IP65	MDME202GC□	MDME202SC□
	IP67	MDME202G1□	MDME202S1□
Applicable driver *2	Model No. A5II, A5 series	MED◇T7364	
	A5IE, A5E series	MED◇T7364E	-
Frame symbol		E-frame	
Power supply capacity (kVA)		3.3	
Rated output (W)		2000	
Rated torque (N·m)		9.55	
Momentary Max. peak torque (N·m)		28.6	
Rated current (A(rms))		11.5	
Max. current (A(o-p))		49	
Regenerative brake frequency (times/min) Note1	Without option	No limit Note2	
	DV0P4285	No limit Note2	
Rated rotational speed (r/min)		2000	
Max. rotational speed (r/min)		3000	
Moment of inertia of rotor (×10 <sup>-4</sup> kg·m <sup>2</sup> )	Without brake	8.72	
	With brake	10.0	
Recommended moment of inertia ratio of the load and the rotor Note3		10 times or less	
Rotary encoder specifications Note5	20-bit Incremental		17-bit Absolute
	Resolution per single turn	1,048,576	131,072

• **Brake specifications** (For details, refer to P.183)  
 (This brake will be released when it is energized.)  
 (Do not use this for braking the motor in motion.)

Static friction torque (N·m)	13.7 or more
Engaging time (ms)	100 or less
Releasing time (ms) Note4	50 or less
Exciting current (DC) (A)	0.79±10 %
Releasing voltage (DC) (V)	2 or more
Exciting voltage (DC) (V)	24±2.4

• **Permissible load** (For details, refer to P.183)

During assembly	Radial load P-direction (N)	980
	Thrust load A-direction (N)	588
	Thrust load B-direction (N)	686
During operation	Radial load P-direction (N)	490
	Thrust load A, B-direction (N)	196

• For details of Note 1 to Note 5, refer to P.182, 183.

• Dimensions of Driver, refer to P.44.

\*1 Motor specifications: □

\*2 The product that the end of driver model designation has "E" is "Position control type". Detail of model designation, refer to P.16.

\*3 ◇ in number of applicable driver represents the series. For more information about the part number, please refer to P.16.

Torque characteristics (at AC200 V of power voltage <Dotted line represents the torque at 10 % less supply voltage.>)

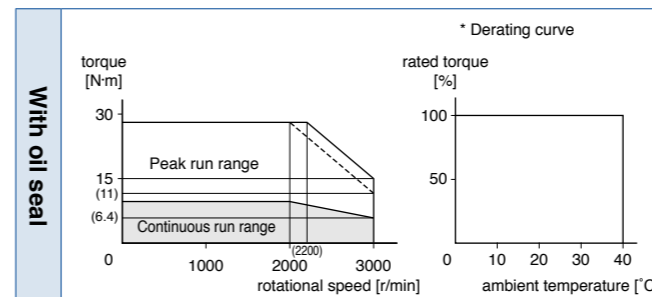

Dimensions

(For IP67 motor, refer to P.138.)

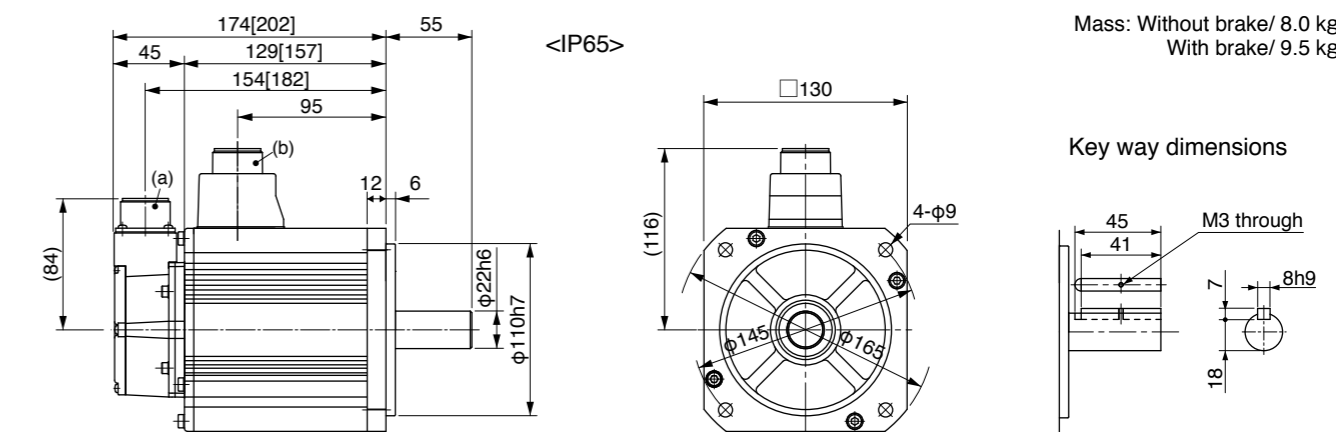

(a) Encoder connector  
 (b) Motor/Brake connector

\* Figures in [ ] represent the dimensions with brake.

[Unit: mm]

<Cautions> Reduce the moment of inertia ratio if high speed response operation is required. Dimensions are subject to change without notice. Contact us or a dealer for the latest information. Read the Instruction Manual carefully and understand all precautions and remarks before using the products.

Specifications

		AC200 V	
Motor model *1	IP65	MDME302GC□	MDME302SC□
	IP67	MDME302G1□	MDME302S1□
Applicable driver *2	Model No. A5II, A5 series	MFD◇TA390	
	A5IE, A5E series	MFD◇TA390E	-
Frame symbol		F-frame	
Power supply capacity (kVA)		4.5	
Rated output (W)		3000	
Rated torque (N·m)		14.3	
Momentary Max. peak torque (N·m)		43.0	
Rated current (A(rms))		17.4	
Max. current (A(o-p))		74	
Regenerative brake frequency (times/min) Note1	Without option	No limit Note2	
	DV0P4285×2	No limit Note2	
Rated rotational speed (r/min)		2000	
Max. rotational speed (r/min)		3000	
Moment of inertia of rotor (×10 <sup>-4</sup> kg·m <sup>2</sup> )	Without brake	12.9	
	With brake	14.2	
Recommended moment of inertia ratio of the load and the rotor Note3		10 times or less	
Rotary encoder specifications Note5	20-bit Incremental		17-bit Absolute
	Resolution per single turn	1,048,576	131,072

• **Brake specifications** (For details, refer to P.183)  
 (This brake will be released when it is energized.)  
 (Do not use this for braking the motor in motion.)

Static friction torque (N·m)	16.2 or more
Engaging time (ms)	110 or less
Releasing time (ms) Note4	50 or less
Exciting current (DC) (A)	0.90±10 %
Releasing voltage (DC) (V)	2 or more
Exciting voltage (DC) (V)	24±2.4

• **Permissible load** (For details, refer to P.183)

During assembly	Radial load P-direction (N)	980
	Thrust load A-direction (N)	588
	Thrust load B-direction (N)	686
During operation	Radial load P-direction (N)	784
	Thrust load A, B-direction (N)	343

• For details of Note 1 to Note 5, refer to P.182, 183.

• Dimensions of Driver, refer to P.45.

\*1 Motor specifications: □

\*2 The product that the end of driver model designation has "E" is "Position control type". Detail of model designation, refer to P.16.

\*3 ◇ in number of applicable driver represents the series. For more information about the part number, please refer to P.16.

Torque characteristics (at AC200 V of power voltage <Dotted line represents the torque at 10 % less supply voltage.>)

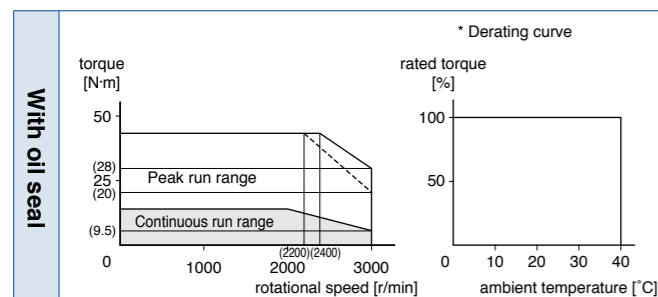

Dimensions

(For IP67 motor, refer to P.139.)

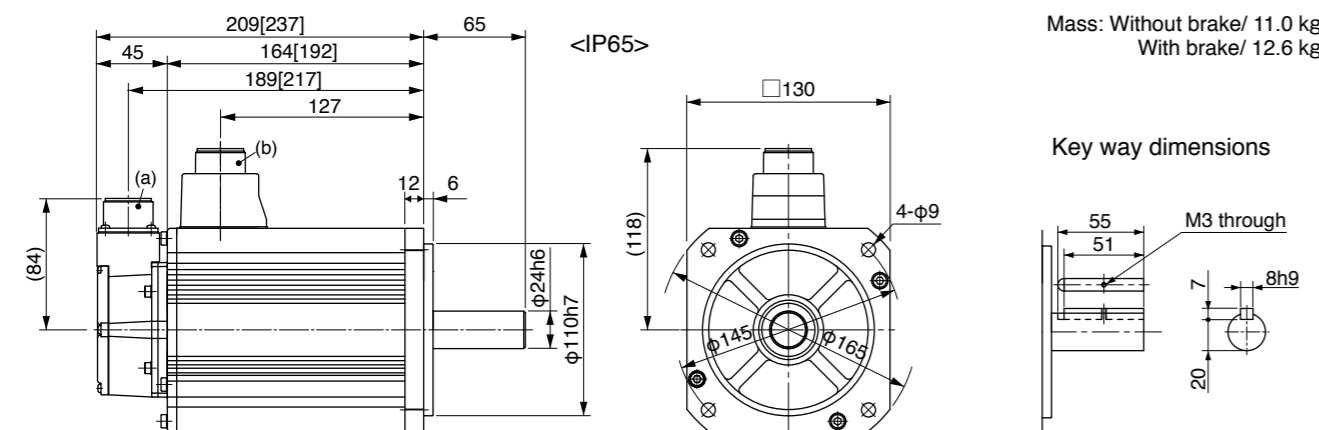

(a) Encoder connector  
 (b) Motor/Brake connector

\* Figures in [ ] represent the dimensions with brake.

[Unit: mm]

<Cautions> Reduce the moment of inertia ratio if high speed response operation is required. Dimensions are subject to change without notice. Contact us or a dealer for the latest information. Read the Instruction Manual carefully and understand all precautions and remarks before using the products.

Specifications

		AC200 V	
Motor model *1	IP65	MDME402GC□	MDME402SC□
	IP67	MDME402G1□	MDME402S1□
Applicable driver *2	Model No. A5II, A5 series	MFD◇TB3A2	
	A5IE, A5E series	MFD◇TB3A2E	-
Frame symbol		F-frame	
Power supply capacity (kVA)		6.0	
Rated output (W)		4000	
Rated torque (N·m)		19.1	
Momentary Max. peak torque (N·m)		57.3	
Rated current (A(rms))		21.0	
Max. current (A(o-p))		89	
Regenerative brake frequency (times/min) Note1	Without option	No limit Note2	
	DV0P4285×2	No limit Note2	
Rated rotational speed (r/min)		2000	
Max. rotational speed (r/min)		3000	
Moment of inertia of rotor (×10 <sup>-4</sup> kg·m <sup>2</sup> )	Without brake	37.6	
	With brake	38.6	
Recommended moment of inertia ratio of the load and the rotor Note3		10 times or less	
Rotary encoder specifications Note5	20-bit Incremental		17-bit Absolute
	Resolution per single turn	1,048,576	131,072

• **Brake specifications** (For details, refer to P.183)  
 (This brake will be released when it is energized.)  
 (Do not use this for braking the motor in motion.)

Static friction torque (N·m)	24.5 or more
Engaging time (ms)	80 or less
Releasing time (ms) Note4	25 or less
Exciting current (DC) (A)	1.3±10 %
Releasing voltage (DC) (V)	2 or more
Exciting voltage (DC) (V)	24±2.4

• **Permissible load** (For details, refer to P.183)

During assembly	Radial load P-direction (N)	1666
	Thrust load A-direction (N)	784
	Thrust load B-direction (N)	980
During operation	Radial load P-direction (N)	784
	Thrust load A, B-direction (N)	343

• For details of Note 1 to Note 5, refer to P.182, 183.

• Dimensions of Driver, refer to P.45.

\*1 Motor specifications: □

\*2 The product that the end of driver model designation has "E" is "Position control type". Detail of model designation, refer to P.16.

\*3 ◇ in number of applicable driver represents the series. For more information about the part number, please refer to P.16.

Torque characteristics (at AC200 V of power voltage <Dotted line represents the torque at 10 % less supply voltage.>)

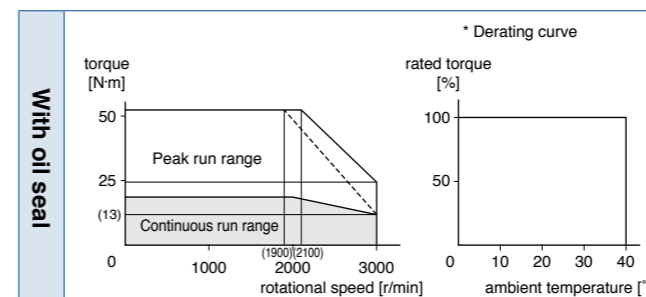

Dimensions

(For IP67 motor, refer to P.139.)

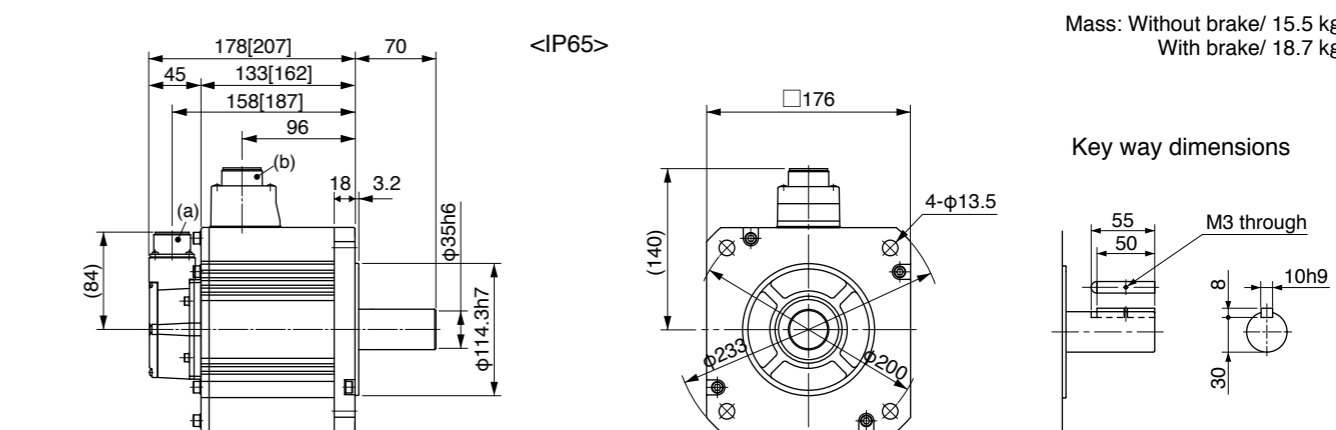

(a) Encoder connector  
 (b) Motor/Brake connector

\* Figures in [ ] represent the dimensions with brake.

[Unit: mm]

<Cautions> Reduce the moment of inertia ratio if high speed response operation is required. Dimensions are subject to change without notice. Contact us or a dealer for the latest information. Read the Instruction Manual carefully and understand all precautions and remarks before using the products.

Specifications

		AC200 V	
Motor model *1	IP65	MDME502GC□	MDME502SC□
	IP67	MDME502G1□	MDME502S1□
Applicable driver *2	Model No. A5II, A5 series	MFD◇TB3A2	
	A5IE, A5E series	MFD◇TB3A2E	-
Frame symbol		F-frame	
Power supply capacity (kVA)		7.5	
Rated output (W)		5000	
Rated torque (N·m)		23.9	
Momentary Max. peak torque (N·m)		71.6	
Rated current (A(rms))		25.9	
Max. current (A(o-p))		110	
Regenerative brake frequency (times/min) Note1	Without option	120	
	DV0P4285×2	No limit Note2	
Rated rotational speed (r/min)		2000	
Max. rotational speed (r/min)		3000	
Moment of inertia of rotor (×10 <sup>-4</sup> kg·m <sup>2</sup> )	Without brake	48.0	
	With brake	48.8	
Recommended moment of inertia ratio of the load and the rotor Note3		10 times or less	
Rotary encoder specifications Note5	20-bit Incremental		17-bit Absolute
	Resolution per single turn	1,048,576	131,072

• **Brake specifications** (For details, refer to P.183)  
 (This brake will be released when it is energized.)  
 (Do not use this for braking the motor in motion.)

Static friction torque (N·m)	24.5 or more
Engaging time (ms)	80 or less
Releasing time (ms) Note4	25 or less
Exciting current (DC) (A)	1.3±10 %
Releasing voltage (DC) (V)	2 or more
Exciting voltage (DC) (V)	24±2.4

• **Permissible load** (For details, refer to P.183)

During assembly	Radial load P-direction (N)	1666
	Thrust load A-direction (N)	784
	Thrust load B-direction (N)	980
During operation	Radial load P-direction (N)	784
	Thrust load A, B-direction (N)	343

• For details of Note 1 to Note 5, refer to P.182, 183.  
 • Dimensions of Driver, refer to P.45.

\*1 Motor specifications: □  
 \*2 The product that the end of driver model designation has "E" is "Position control type". Detail of model designation, refer to P.16.  
 \*3 ◇ in number of applicable driver represents the series. For more information about the part number, please refer to P.16.

Torque characteristics (at AC200 V of power voltage <Dotted line represents the torque at 10 % less supply voltage.>)

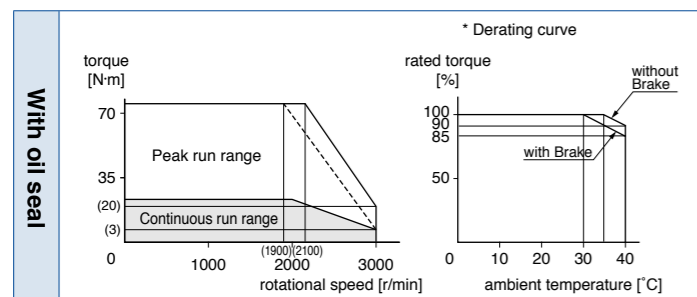

Dimensions

(For IP67 motor, refer to P.139.)

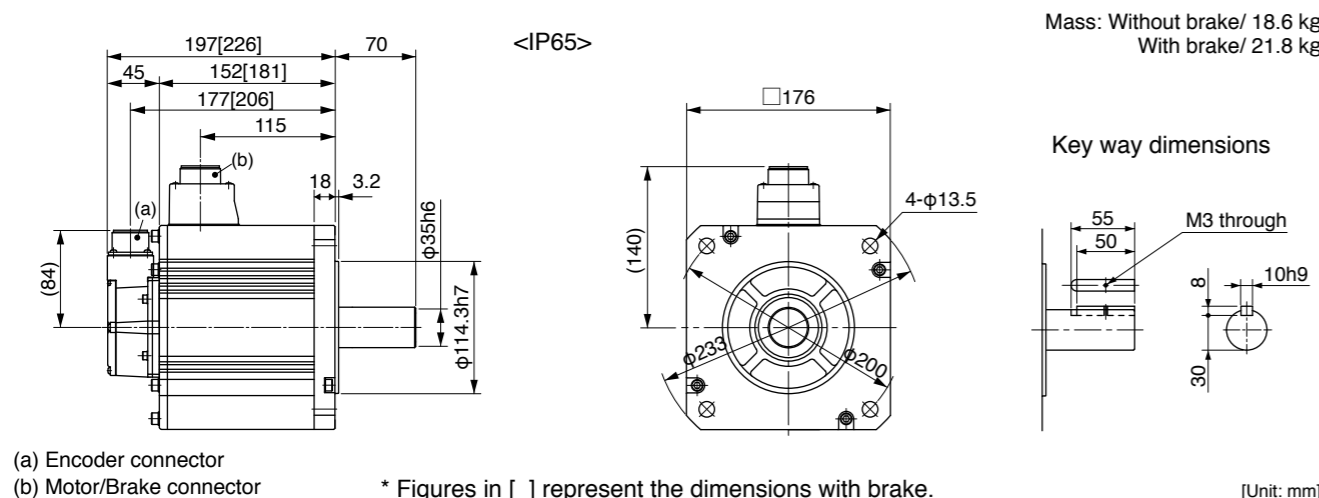

<Cautions> Reduce the moment of inertia ratio if high speed response operation is required. Dimensions are subject to change without notice. Contact us or a dealer for the latest information. Read the Instruction Manual carefully and understand all precautions and remarks before using the products.

Specifications

		AC200 V	
Motor model *1	IP65	-	-
	IP67	MDME752G1□	MDME752S1□
Applicable driver *2	Model No. A5II, A5 series	MGD◇TC3B4	
	A5IE, A5E series	-	-
Frame symbol		G-frame	
Power supply capacity (kVA)		11	
Rated output (W)		7500	
Rated torque (N·m)		47.8	
Momentary Max. peak torque (N·m)		119	
Rated current (A(rms))		44.0	
Max. current (A(o-p))		165	
Regenerative brake frequency (times/min) Note1	Without option	No limit Note2	
	DV0P4285×3	No limit Note2	
Rated rotational speed (r/min)		1500	
Max. rotational speed (r/min)		3000	
Moment of inertia of rotor (×10 <sup>-4</sup> kg·m <sup>2</sup> )	Without brake	101	
	With brake	107	
Recommended moment of inertia ratio of the load and the rotor Note3		10 times or less	
Rotary encoder specifications Note5	20-bit Incremental		17-bit Absolute
	Resolution per single turn	1,048,576	131,072

• **Brake specifications** (For details, refer to P.183)  
 (This brake will be released when it is energized.)  
 (Do not use this for braking the motor in motion.)

Static friction torque (N·m)	58.8 or more
Engaging time (ms)	150 or less
Releasing time (ms) Note4	50 or less
Exciting current (DC) (A)	1.4±10 %
Releasing voltage (DC) (V)	2 or more
Exciting voltage (DC) (V)	24±2.4

• **Permissible load** (For details, refer to P.183)

During assembly	Radial load P-direction (N)	2058
	Thrust load A-direction (N)	980
	Thrust load B-direction (N)	1176
During operation	Radial load P-direction (N)	1176
	Thrust load A, B-direction (N)	490

• For details of Note 1 to Note 5, refer to P.182, 183.  
 • Dimensions of Driver, refer to P.46.

\*1 Motor specifications: □  
 \*2 The product that the end of driver model designation has "E" is "Position control type". Detail of model designation, refer to P.16.  
 \*3 ◇ in number of applicable driver represents the series. For more information about the part number, please refer to P.16.

Torque characteristics (at AC200 V of power voltage <Dotted line represents the torque at 10 % less supply voltage.>)

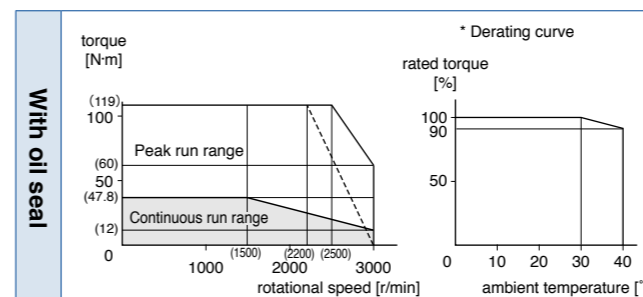

Dimensions

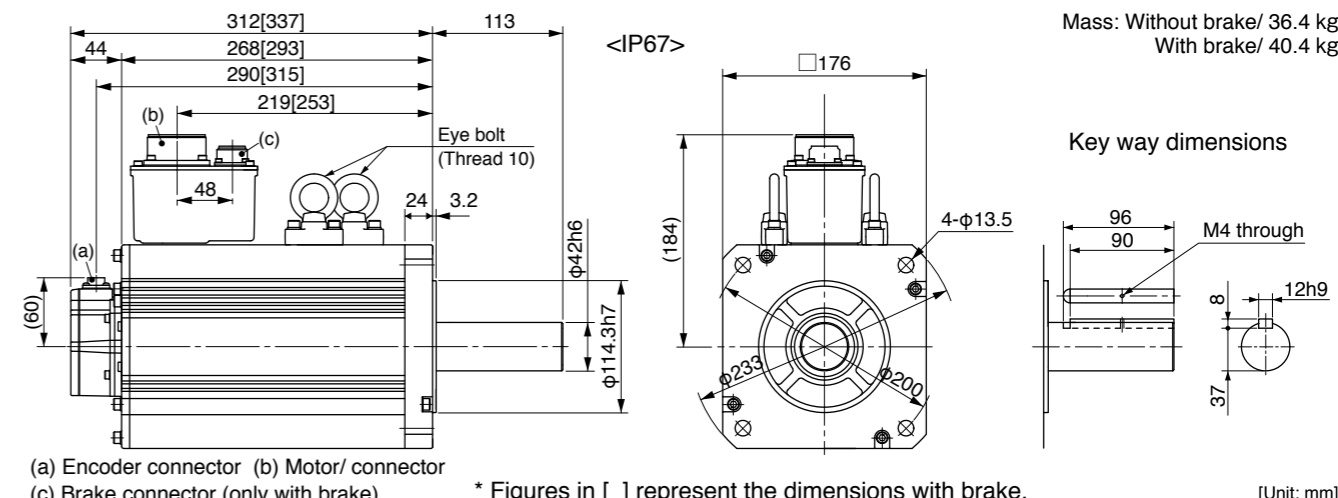

<Cautions> Reduce the moment of inertia ratio if high speed response operation is required. Dimensions are subject to change without notice. Contact us or a dealer for the latest information. Read the Instruction Manual carefully and understand all precautions and remarks before using the products.

Specifications

		AC200 V	
Motor model *1	IP65	-	-
	IP67	MDMEC12G1□	MDMEC12S1□
Applicable driver *2	Model No.	A5II, A5 series	MHD◇TC3B4
	Frame symbol	A5IE, A5E series	-
Power supply capacity (kVA)		17	
Rated output (W)		11000	
Rated torque (N·m)		70.0	
Momentary Max. peak torque (N·m)		175	
Rated current (A(rms))		54.2	
Max. current (A(o-p))		203	
Regenerative brake frequency (times/min) Note1	Without option	No limit Note2	-
	DV0PM20058	No limit Note2	-
Rated rotational speed (r/min)		1500	
Max. rotational speed (r/min)		2000	
Moment of inertia of rotor (x10 <sup>-4</sup> kg·m <sup>2</sup> )	Without brake	212	
	With brake	220	
Recommended moment of inertia ratio of the load and the rotor Note3		10 times or less	
Rotary encoder specifications Note5	20-bit Incremental	1,048,576	17-bit Absolute
	Resolution per single turn	1,048,576	131,072

• **Brake specifications** (For details, refer to P.183)  
 (This brake will be released when it is energized.)  
 (Do not use this for braking the motor in motion.)

Static friction torque (N·m)	100 or more
Engaging time (ms)	300 or less
Releasing time (ms) Note4	140 or less
Exciting current (DC) (A)	1.08±10 %
Releasing voltage (DC) (V)	2 or more
Exciting voltage (DC) (V)	24±2.4

• **Permissible load** (For details, refer to P.183)

During assembly	Radial load P-direction (N)	4508
	Thrust load A-direction (N)	1470
	Thrust load B-direction (N)	1764
During operation	Radial load P-direction (N)	2254
	Thrust load A, B-direction (N)	686

• For details of Note 1 to Note 5, refer to P.182, 183.

• Dimensions of Driver, refer to P.47.

\*1 Motor specifications: □

\*2 The product that the end of driver model designation has "E" is "Position control type". Detail of model designation, refer to P.16.

\*3 ◇ in number of applicable driver represents the series. For more information about the part number, please refer to P.16.

Torque characteristics (at AC200 V of power voltage <Dotted line represents the torque at 10 % less supply voltage.>)

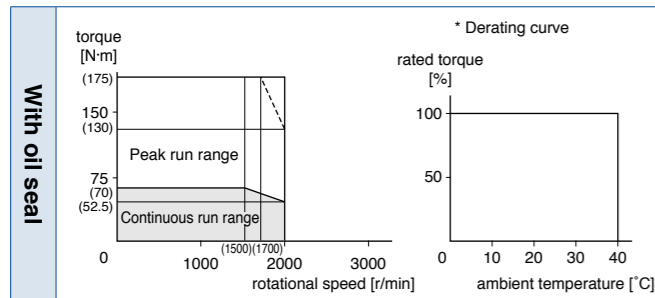

Dimensions

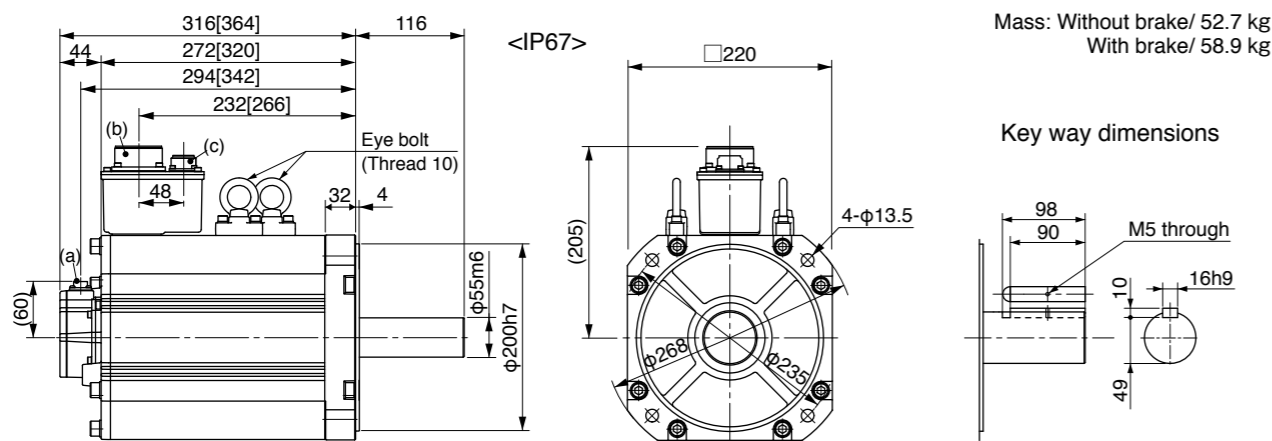

(a) Encoder connector (b) Motor/ connector (c) Brake connector (only with brake) \* Figures in [ ] represent the dimensions with brake. [Unit: mm]

<Cautions> Reduce the moment of inertia ratio if high speed response operation is required. Dimensions are subject to change without notice. Contact us or a dealer for the latest information. Read the Instruction Manual carefully and understand all precautions and remarks before using the products.

Specifications

		AC200 V	
Motor model *1	IP65	-	-
	IP67	MDMEC52G1□	MDMEC52S1□
Applicable driver *2	Model No.	A5II, A5 series	MHD◇TC3B4
	Frame symbol	A5IE, A5E series	-
Power supply capacity (kVA)		22	
Rated output (W)		15000	
Rated torque (N·m)		95.5	
Momentary Max. peak torque (N·m)		224	
Rated current (A(rms))		66.1	
Max. current (A(o-p))		236	
Regenerative brake frequency (times/min) Note1	Without option	No limit Note2	-
	DV0PM20058	No limit Note2	-
Rated rotational speed (r/min)		1500	
Max. rotational speed (r/min)		2000	
Moment of inertia of rotor (x10 <sup>-4</sup> kg·m <sup>2</sup> )	Without brake	302	
	With brake	311	
Recommended moment of inertia ratio of the load and the rotor Note3		10 times or less	
Rotary encoder specifications Note5	20-bit Incremental	1,048,576	17-bit Absolute
	Resolution per single turn	1,048,576	131,072

• **Brake specifications** (For details, refer to P.183)  
 (This brake will be released when it is energized.)  
 (Do not use this for braking the motor in motion.)

Static friction torque (N·m)	100 or more
Engaging time (ms)	300 or less
Releasing time (ms) Note4	140 or less
Exciting current (DC) (A)	1.08±10 %
Releasing voltage (DC) (V)	2 or more
Exciting voltage (DC) (V)	24±2.4

• **Permissible load** (For details, refer to P.183)

During assembly	Radial load P-direction (N)	4508
	Thrust load A-direction (N)	1470
	Thrust load B-direction (N)	1764
During operation	Radial load P-direction (N)	2254
	Thrust load A, B-direction (N)	686

• For details of Note 1 to Note 5, refer to P.182, 183.

• Dimensions of Driver, refer to P.47.

\*1 Motor specifications: □

\*2 The product that the end of driver model designation has "E" is "Position control type". Detail of model designation, refer to P.16.

\*3 ◇ in number of applicable driver represents the series. For more information about the part number, please refer to P.16.

Torque characteristics (at AC200 V of power voltage <Dotted line represents the torque at 10 % less supply voltage.>)

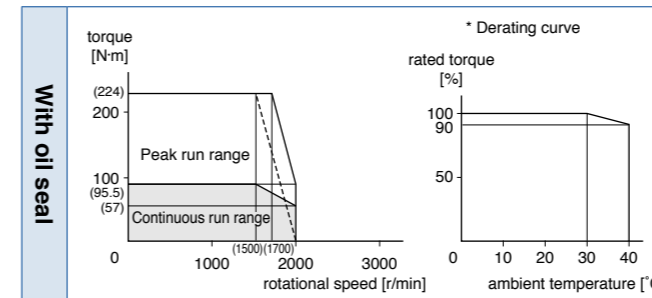

Dimensions

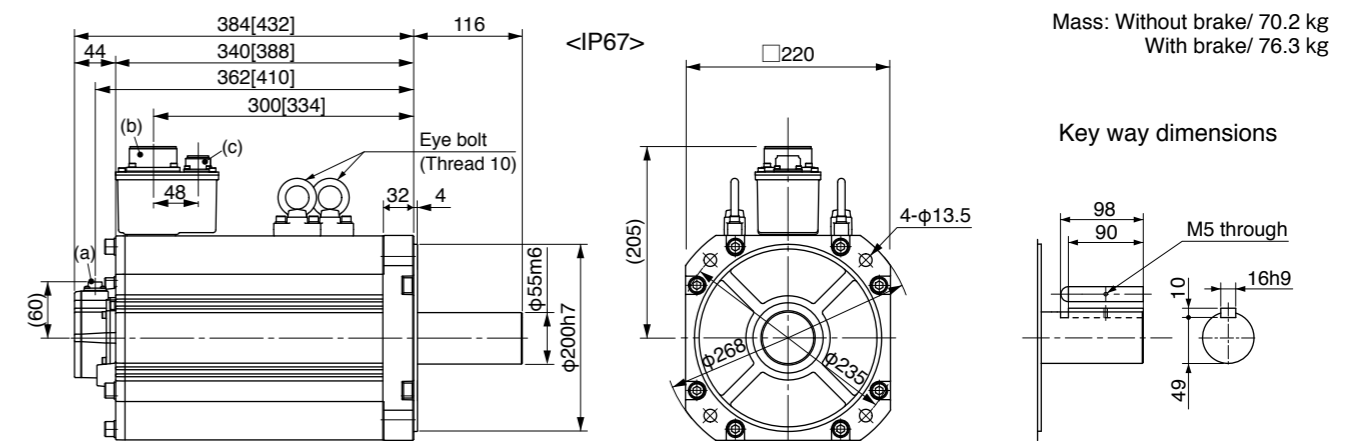

(a) Encoder connector (b) Motor/ connector (c) Brake connector (only with brake) \* Figures in [ ] represent the dimensions with brake. [Unit: mm]

<Cautions> Reduce the moment of inertia ratio if high speed response operation is required. Dimensions are subject to change without notice. Contact us or a dealer for the latest information. Read the Instruction Manual carefully and understand all precautions and remarks before using the products.

Specifications

		AC200 V	
Motor model *1	IP65	-	-
	IP67	MFME152G1□	MFME152S1□
Applicable driver *2	Model No. A5II, A5 series	MDD◇T5540	
	A5IE, A5E series	MDD◇T5540E	-
Frame symbol		D-frame	
Power supply capacity (kVA)		2.3	
Rated output (W)		1500	
Rated torque (N·m)		7.16	
Momentary Max. peak torque (N·m)		21.5	
Rated current (A(rms))		7.5	
Max. current (A(o-p))		32	
Regenerative brake frequency (times/min) Note1	Without option	100	
	DV0P4284	No limit Note2	
Rated rotational speed (r/min)		2000	
Max. rotational speed (r/min)		3000	
Moment of inertia of rotor (x10 <sup>-4</sup> kg·m <sup>2</sup> )	Without brake	18.2	
	With brake	23.5	
Recommended moment of inertia ratio of the load and the rotor Note3		10 times or less	
Rotary encoder specifications Note5	20-bit Incremental		17-bit Absolute
	Resolution per single turn	1,048,576	131,072

• Brake specifications (For details, refer to P.183)

(This brake will be released when it is energized.)  
(Do not use this for braking the motor in motion.)

Static friction torque (N·m)	7.8 or more
Engaging time (ms)	80 or less
Releasing time (ms) Note4	35 or less
Exciting current (DC) (A)	0.83±10 %
Releasing voltage (DC) (V)	2 or more
Exciting voltage (DC) (V)	24±2.4

• Permissible load (For details, refer to P.183)

During assembly	Radial load P-direction (N)	980
	Thrust load A-direction (N)	588
	Thrust load B-direction (N)	686
During operation	Radial load P-direction (N)	490
	Thrust load A, B-direction (N)	196

• For details of Note 1 to Note 5, refer to P.182, 183.

• Dimensions of Driver, refer to P.43.

\*1 Motor specifications: □

\*2 The product that the end of driver model designation has "E" is "Position control type". Detail of model designation, refer to P.16.

\*3 ◇ in number of applicable driver represents the series. For more information about the part number, please refer to P.16.

Torque characteristics (at AC200 V of power voltage <Dotted line represents the torque at 10 % less supply voltage.>)

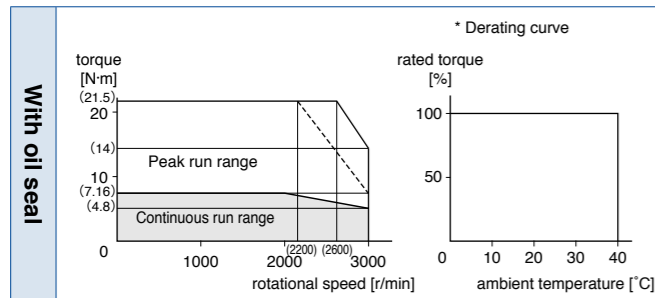

Dimensions

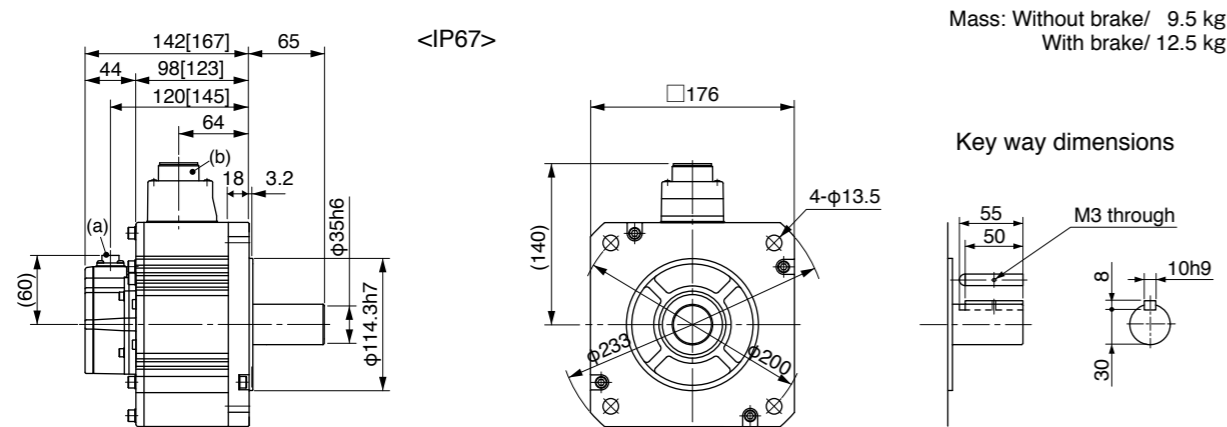

Mass: Without brake/ 9.5 kg  
With brake/ 12.5 kg

(a) Encoder connector  
(b) Motor/Brake connector

\* Figures in [ ] represent the dimensions with brake.

[Unit: mm]

<Cautions> Reduce the moment of inertia ratio if high speed response operation is required. Dimensions are subject to change without notice. Contact us or a dealer for the latest information. Read the Instruction Manual carefully and understand all precautions and remarks before using the products.

Specifications

		AC200 V	
Motor model *1	IP65	-	-
	IP67	MFME252G1□	MFME252S1□
Applicable driver *2	Model No. A5II, A5 series	MED◇T7364	
	A5IE, A5E series	MED◇T7364E	-
Frame symbol		E-frame	
Power supply capacity (kVA)		3.8	
Rated output (W)		2500	
Rated torque (N·m)		11.9	
Momentary Max. peak torque (N·m)		30.4	
Rated current (A(rms))		13.4	
Max. current (A(o-p))		57	
Regenerative brake frequency (times/min) Note1	Without option	75	
	DV0P4285	No limit Note2	
Rated rotational speed (r/min)		2000	
Max. rotational speed (r/min)		3000	
Moment of inertia of rotor (x10 <sup>-4</sup> kg·m <sup>2</sup> )	Without brake	35.8	
	With brake	45.2	
Recommended moment of inertia ratio of the load and the rotor Note3		10 times or less	
Rotary encoder specifications Note5	20-bit Incremental		17-bit Absolute
	Resolution per single turn	1,048,576	131,072

• Brake specifications (For details, refer to P.183)

(This brake will be released when it is energized.)  
(Do not use this for braking the motor in motion.)

Static friction torque (N·m)	21.6 or more
Engaging time (ms)	150 or less
Releasing time (ms) Note4	100 or less
Exciting current (DC) (A)	0.75±10 %
Releasing voltage (DC) (V)	2 or more
Exciting voltage (DC) (V)	24±2.4

• Permissible load (For details, refer to P.183)

During assembly	Radial load P-direction (N)	1862
	Thrust load A-direction (N)	686
	Thrust load B-direction (N)	686
During operation	Radial load P-direction (N)	784
	Thrust load A, B-direction (N)	294

• For details of Note 1 to Note 5, refer to P.182, 183.

• Dimensions of Driver, refer to P.44.

\*1 Motor specifications: □

\*2 The product that the end of driver model designation has "E" is "Position control type". Detail of model designation, refer to P.16.

\*3 ◇ in number of applicable driver represents the series. For more information about the part number, please refer to P.16.

Torque characteristics (at AC200 V of power voltage <Dotted line represents the torque at 10 % less supply voltage.>)

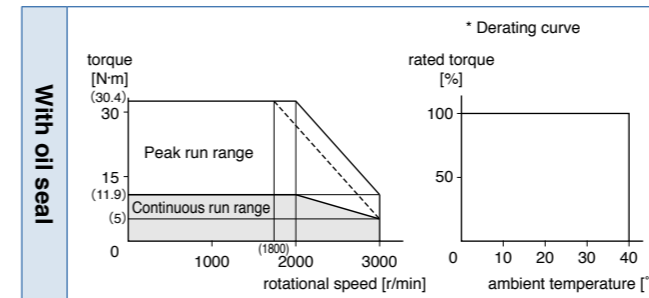

Dimensions

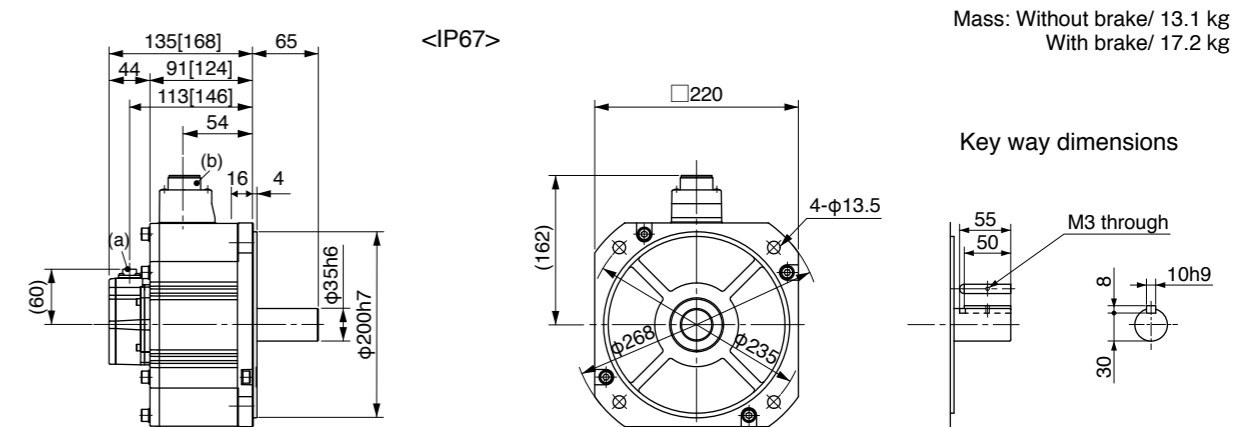

Mass: Without brake/ 13.1 kg  
With brake/ 17.2 kg

(a) Encoder connector  
(b) Motor/Brake connector

\* Figures in [ ] represent the dimensions with brake.

[Unit: mm]

<Cautions> Reduce the moment of inertia ratio if high speed response operation is required. Dimensions are subject to change without notice. Contact us or a dealer for the latest information. Read the Instruction Manual carefully and understand all precautions and remarks before using the products.

Specifications

		AC200 V	
Motor model *1	IP65	-	-
	IP67	MFME452G1□	MFME452S1□
Applicable driver *2	Model No. A5II, A5 series	MFD◇TB3A2	
	A5IE, A5E series	MFD◇TB3A2E	-
Frame symbol		F-frame	
Power supply capacity (kVA)		6.8	
Rated output (W)		4500	
Rated torque (N·m)		21.5	
Momentary Max. peak torque (N·m)		54.9	
Rated current (A(rms))		24.7	
Max. current (A(o-p))		105	
Regenerative brake frequency (times/min) Note1	Without option	67	
	DV0P4285×2	375	
Rated rotational speed (r/min)		2000	
Max. rotational speed (r/min)		3000	
Moment of inertia of rotor (×10 <sup>-4</sup> kg·m <sup>2</sup> )	Without brake	63.1	
	With brake	70.9	
Recommended moment of inertia ratio of the load and the rotor Note3		10 times or less	
Rotary encoder specifications Note5	20-bit Incremental		17-bit Absolute
	Resolution per single turn	1,048,576	131,072

• **Brake specifications** (For details, refer to P.183)  
 (This brake will be released when it is energized.)  
 (Do not use this for braking the motor in motion.)

Static friction torque (N·m)	31.4 or more
Engaging time (ms)	150 or less
Releasing time (ms) Note4	100 or less
Exciting current (DC) (A)	0.75±10 %
Releasing voltage (DC) (V)	2 or more
Exciting voltage (DC) (V)	24±2.4

• **Permissible load** (For details, refer to P.183)

During assembly	Radial load P-direction (N)	1862
	Thrust load A-direction (N)	686
	Thrust load B-direction (N)	686
During operation	Radial load P-direction (N)	784
	Thrust load A, B-direction (N)	294

• For details of Note 1 to Note 5, refer to P.182, 183.

• Dimensions of Driver, refer to P.45.

\*1 Motor specifications: □

\*2 The product that the end of driver model designation has "E" is "Position control type". Detail of model designation, refer to P.16.

\*3 ◇ in number of applicable driver represents the series. For more information about the part number, please refer to P.16.

Torque characteristics (at AC200 V of power voltage <Dotted line represents the torque at 10 % less supply voltage.>)

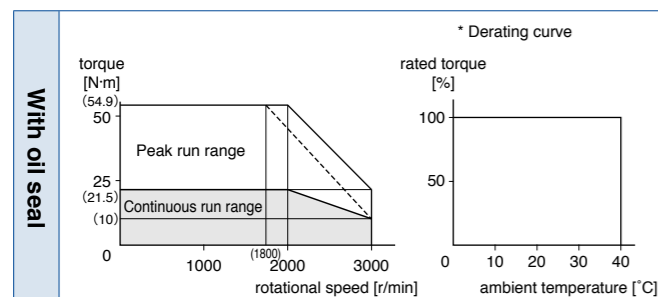

Dimensions

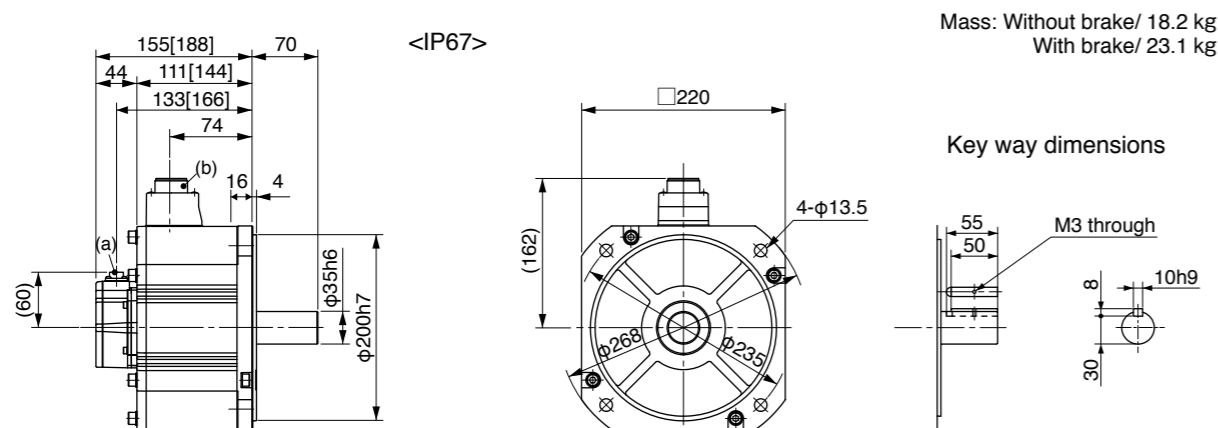

(a) Encoder connector  
 (b) Motor/Brake connector

\* Figures in [ ] represent the dimensions with brake.

[Unit: mm]

<Cautions> Reduce the moment of inertia ratio if high speed response operation is required. Dimensions are subject to change without notice. Contact us or a dealer for the latest information. Read the Instruction Manual carefully and understand all precautions and remarks before using the products.

Specifications

		AC200 V	
Motor model *1	IP65	MGME092GC□	MGME092SC□
	IP67	MGME092G1□	MGME092S1□
Applicable driver *2	Model No. A5II, A5 series	MDD◇T5540	
	A5IE, A5E series	MDD◇T5540E	-
Frame symbol		D-frame	
Power supply capacity (kVA)		1.8	
Rated output (W)		900	
Rated torque (N·m)		8.59	
Momentary Max. peak torque (N·m)		19.3	
Rated current (A(rms))		7.6	
Max. current (A(o-p))		24	
Regenerative brake frequency (times/min) Note1	Without option	No limit Note2	
	DV0P4284	No limit Note2	
Rated rotational speed (r/min)		1000	
Max. rotational speed (r/min)		2000	
Moment of inertia of rotor (×10 <sup>-4</sup> kg·m <sup>2</sup> )	Without brake	6.70	
	With brake	7.99	
Recommended moment of inertia ratio of the load and the rotor Note3		10 times or less	
Rotary encoder specifications Note5	20-bit Incremental		17-bit Absolute
	Resolution per single turn	1,048,576	131,072

• **Brake specifications** (For details, refer to P.183)  
 (This brake will be released when it is energized.)  
 (Do not use this for braking the motor in motion.)

Static friction torque (N·m)	13.7 or more
Engaging time (ms)	100 or less
Releasing time (ms) Note4	50 or less
Exciting current (DC) (A)	0.79±10 %
Releasing voltage (DC) (V)	2 or more
Exciting voltage (DC) (V)	24±2.4

• **Permissible load** (For details, refer to P.183)

During assembly	Radial load P-direction (N)	980
	Thrust load A-direction (N)	588
	Thrust load B-direction (N)	686
During operation	Radial load P-direction (N)	686
	Thrust load A, B-direction (N)	196

• For details of Note 1 to Note 5, refer to P.182, 183.

• Dimensions of Driver, refer to P.43.

\*1 Motor specifications: □

\*2 The product that the end of driver model designation has "E" is "Position control type". Detail of model designation, refer to P.16.

\*3 ◇ in number of applicable driver represents the series. For more information about the part number, please refer to P.16.

Torque characteristics (at AC200 V of power voltage <Dotted line represents the torque at 10 % less supply voltage.>)

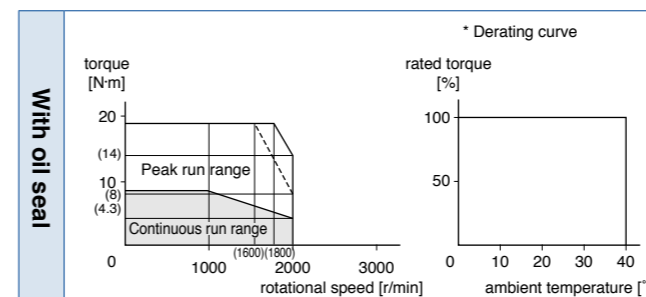

Dimensions

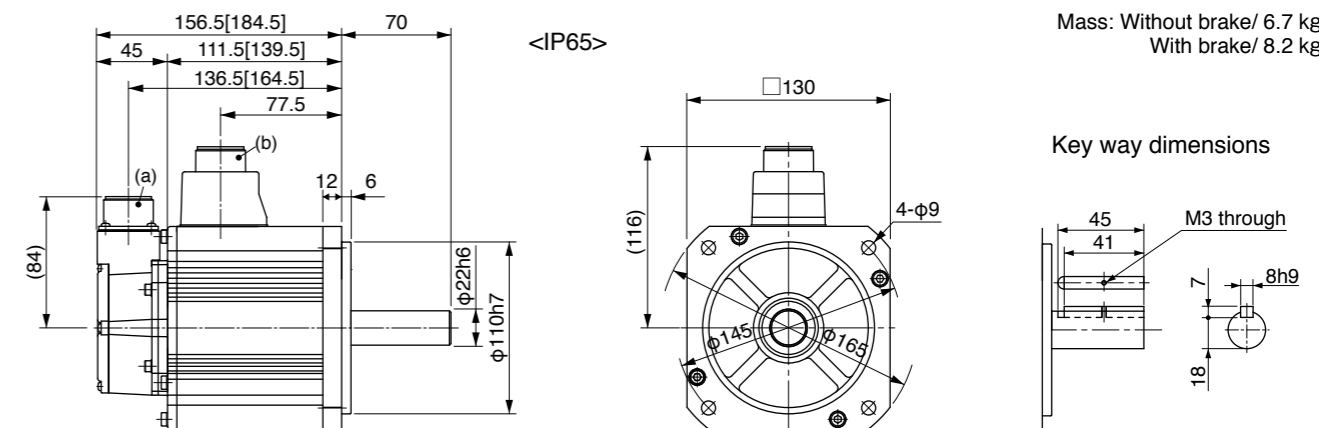

(a) Encoder connector  
 (b) Motor/Brake connector

\* Figures in [ ] represent the dimensions with brake.

[Unit: mm]

<Cautions> Reduce the moment of inertia ratio if high speed response operation is required. Dimensions are subject to change without notice. Contact us or a dealer for the latest information. Read the Instruction Manual carefully and understand all precautions and remarks before using the products.

Specifications

		AC200 V	
Motor model *1	IP65	MGME202GC□	MGME202SC□
	IP67	MGME202G1□	MGME202S1□
Applicable driver *2	Model No. A5II, A5 series	MFD◇TA390	
	A5IE, A5E series	MFD◇TA390E	-
Frame symbol		F-frame	
Power supply capacity (kVA)	3.8		
Rated output (W)	2000		
Rated torque (N·m)	19.1		
Momentary Max. peak torque (N·m)	47.7		
Rated current (A(rms))	17.0		
Max. current (A(o-p))	60		
Regenerative brake frequency (times/min) Note1	Without option	No limit Note2	
	DV0P4285×2	No limit Note2	
Rated rotational speed (r/min)	1000		
Max. rotational speed (r/min)	2000		
Moment of inertia of rotor (×10 <sup>-4</sup> kg·m <sup>2</sup> )	Without brake	30.3	
	With brake	31.4	
Recommended moment of inertia ratio of the load and the rotor Note3	10 times or less		
Rotary encoder specifications Note5	20-bit Incremental	17-bit Absolute	
	Resolution per single turn	1,048,576	131,072

• **Brake specifications** (For details, refer to P.183)  
 (This brake will be released when it is energized.)  
 (Do not use this for braking the motor in motion.)

Static friction torque (N·m)	24.5 or more
Engaging time (ms)	80 or less
Releasing time (ms) Note4	25 or less
Exciting current (DC) (A)	1.3±10 %
Releasing voltage (DC) (V)	2 or more
Exciting voltage (DC) (V)	24±2.4

• **Permissible load** (For details, refer to P.183)

During assembly	Radial load P-direction (N)	1666
	Thrust load A-direction (N)	784
	Thrust load B-direction (N)	980
During operation	Radial load P-direction (N)	1176
	Thrust load A, B-direction (N)	490

• For details of Note 1 to Note 5, refer to P.182, 183.

• Dimensions of Driver, refer to P.45.

\*1 Motor specifications: □

\*2 The product that the end of driver model designation has "E" is "Position control type". Detail of model designation, refer to P.16.

\*3 ◇ in number of applicable driver represents the series. For more information about the part number, please refer to P.16.

Torque characteristics (at AC200 V of power voltage <Dotted line represents the torque at 10 % less supply voltage.>)

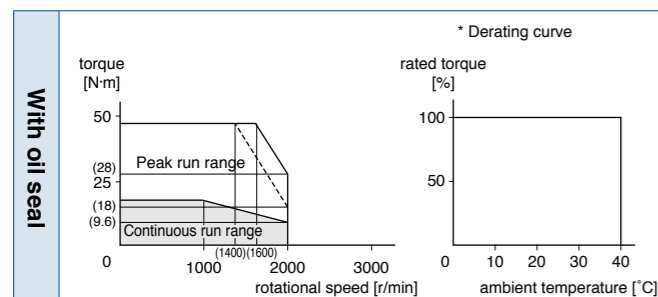

Dimensions

(For IP67 motor, refer to P.139.)

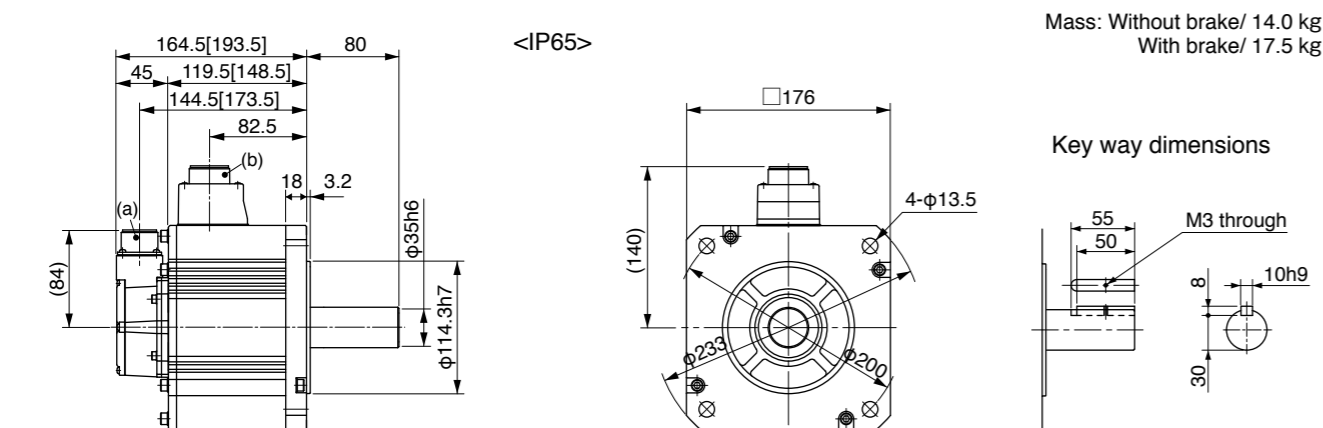

(a) Encoder connector  
 (b) Motor/Brake connector

\* Figures in [ ] represent the dimensions with brake.

[Unit: mm]

<Cautions> Reduce the moment of inertia ratio if high speed response operation is required. Dimensions are subject to change without notice. Contact us or a dealer for the latest information. Read the Instruction Manual carefully and understand all precautions and remarks before using the products.

Specifications

		AC200 V	
Motor model *1	IP65	MGME302GC□	MGME302SC□
	IP67	MGME302G1□	MGME302S1□
Applicable driver *2	Model No. A5II, A5 series	MFD◇TB3A2	
	A5IE, A5E series	MFD◇TB3A2E	-
Frame symbol		F-frame	
Power supply capacity (kVA)	4.5		
Rated output (W)	3000		
Rated torque (N·m)	28.7		
Momentary Max. peak torque (N·m)	71.7		
Rated current (A(rms))	22.6		
Max. current (A(o-p))	80		
Regenerative brake frequency (times/min) Note1	Without option	No limit Note2	
	DV0P4285×2	No limit Note2	
Rated rotational speed (r/min)	1000		
Max. rotational speed (r/min)	2000		
Moment of inertia of rotor (×10 <sup>-4</sup> kg·m <sup>2</sup> )	Without brake	48.4	
	With brake	49.2	
Recommended moment of inertia ratio of the load and the rotor Note3	10 times or less		
Rotary encoder specifications Note5	20-bit Incremental	17-bit Absolute	
	Resolution per single turn	1,048,576	131,072

• **Brake specifications** (For details, refer to P.183)  
 (This brake will be released when it is energized.)  
 (Do not use this for braking the motor in motion.)

Static friction torque (N·m)	58.8 or more
Engaging time (ms)	150 or less
Releasing time (ms) Note4	50 or less
Exciting current (DC) (A)	1.4±10 %
Releasing voltage (DC) (V)	2 or more
Exciting voltage (DC) (V)	24±2.4

• **Permissible load** (For details, refer to P.183)

During assembly	Radial load P-direction (N)	2058
	Thrust load A-direction (N)	980
	Thrust load B-direction (N)	1176
During operation	Radial load P-direction (N)	1470
	Thrust load A, B-direction (N)	490

• For details of Note 1 to Note 5, refer to P.182, 183.

• Dimensions of Driver, refer to P.45.

\*1 Motor specifications: □

\*2 The product that the end of driver model designation has "E" is "Position control type". Detail of model designation, refer to P.16.

\*3 ◇ in number of applicable driver represents the series. For more information about the part number, please refer to P.16.

Torque characteristics (at AC200 V of power voltage <Dotted line represents the torque at 10 % less supply voltage.>)

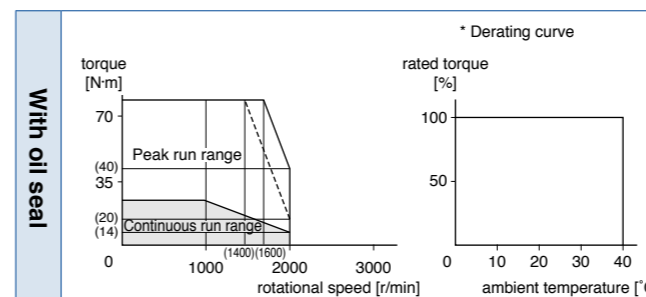

Dimensions

(For IP67 motor, refer to P.139.)

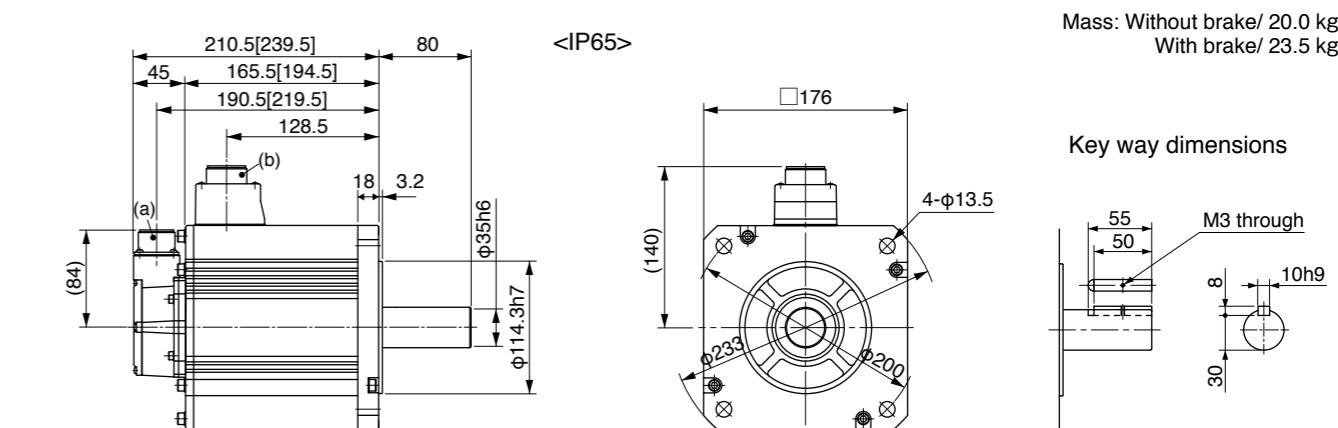

(a) Encoder connector  
 (b) Motor/Brake connector

\* Figures in [ ] represent the dimensions with brake.

[Unit: mm]

<Cautions> Reduce the moment of inertia ratio if high speed response operation is required. Dimensions are subject to change without notice. Contact us or a dealer for the latest information. Read the Instruction Manual carefully and understand all precautions and remarks before using the products.



Specifications

		AC200 V	
Motor model *1	IP65	-	-
	IP67	MGME452G1□	MGME452S1□
Applicable driver *2	Model No.	A5II, A5 series	MFD◇TB3A2
		A5IE, A5E series	MFD◇TB3A2E
Frame symbol		F-frame	
Power supply capacity (kVA)	7.5		
Rated output (W)	4500		
Rated torque (N·m)	43.0		
Momentary Max. peak torque (N·m)	107		
Rated current (A(rms))	29.7		
Max. current (A(o-p))	110		
Regenerative brake frequency (times/min) Note1	Without option	No limit Note2	
	DV0P4285×2	No limit Note2	
Rated rotational speed (r/min)	1000		
Max. rotational speed (r/min)	2000		
Moment of inertia of rotor (×10 <sup>-4</sup> kg·m <sup>2</sup> )	Without brake	79.1	
	With brake	84.4	
Recommended moment of inertia ratio of the load and the rotor Note3	10 times or less		
Rotary encoder specifications Note5	20-bit Incremental	17-bit Absolute	
	Resolution per single turn	1,048,576	131,072

• **Brake specifications** (For details, refer to P.183)  
 (This brake will be released when it is energized.)  
 (Do not use this for braking the motor in motion.)

Static friction torque (N·m)	58.8 or more
Engaging time (ms)	150 or less
Releasing time (ms) Note4	50 or less
Exciting current (DC) (A)	1.4±10 %
Releasing voltage (DC) (V)	2 or more
Exciting voltage (DC) (V)	24±2.4

• **Permissible load** (For details, refer to P.183)

During assembly	Radial load P-direction (N)	2058
	Thrust load A-direction (N)	980
	Thrust load B-direction (N)	1176
During operation	Radial load P-direction (N)	1470
	Thrust load A, B-direction (N)	490

• For details of Note 1 to Note 5, refer to P.182, 183.

• Dimensions of Driver, refer to P.45.

\*1 Motor specifications: □

\*2 The product that the end of driver model designation has "E" is "Position control type". Detail of model designation, refer to P.16.

\*3 ◇ in number of applicable driver represents the series. For more information about the part number, please refer to P.16.

Torque characteristics (at AC200 V of power voltage <Dotted line represents the torque at 10 % less supply voltage.>)

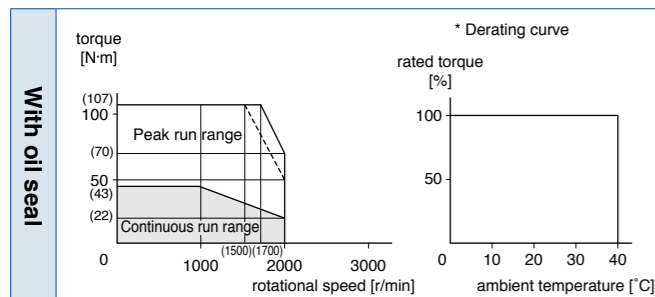

Dimensions

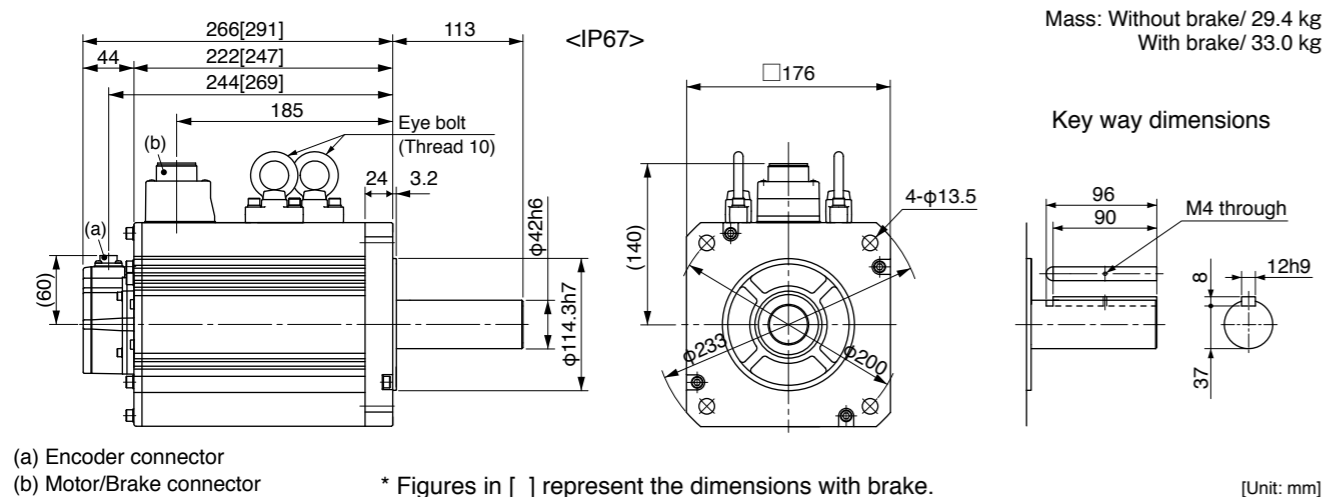

<Cautions> Reduce the moment of inertia ratio if high speed response operation is required. Dimensions are subject to change without notice. Contact us or a dealer for the latest information. Read the Instruction Manual carefully and understand all precautions and remarks before using the products.

Specifications

		AC200 V	
Motor model *1	IP65	-	-
	IP67	MGME602G1□	MGME602S1□
Applicable driver *2	Model No.	A5II, A5 series	MGD◇TC3B4
		A5IE, A5E series	-
Frame symbol		G-frame	
Power supply capacity (kVA)	9.0		
Rated output (W)	6000		
Rated torque (N·m)	57.3		
Momentary Max. peak torque (N·m)	143		
Rated current (A(rms))	38.8		
Max. current (A(o-p))	149		
Regenerative brake frequency (times/min) Note1	Without option	No limit Note2	
	DV0P4285×4	No limit Note2	
Rated rotational speed (r/min)	1000		
Max. rotational speed (r/min)	2000		
Moment of inertia of rotor (×10 <sup>-4</sup> kg·m <sup>2</sup> )	Without brake	101	
	With brake	107	
Recommended moment of inertia ratio of the load and the rotor Note3	10 times or less		
Rotary encoder specifications Note5	20-bit Incremental	17-bit Absolute	
	Resolution per single turn	1,048,576	131,072

• **Brake specifications** (For details, refer to P.183)  
 (This brake will be released when it is energized.)  
 (Do not use this for braking the motor in motion.)

Static friction torque (N·m)	58.8 or more
Engaging time (ms)	150 or less
Releasing time (ms) Note4	50 or less
Exciting current (DC) (A)	1.4±10 %
Releasing voltage (DC) (V)	2 or more
Exciting voltage (DC) (V)	24±2.4

• **Permissible load** (For details, refer to P.183)

During assembly	Radial load P-direction (N)	2058
	Thrust load A-direction (N)	980
	Thrust load B-direction (N)	1176
During operation	Radial load P-direction (N)	1764
	Thrust load A, B-direction (N)	588

• For details of Note 1 to Note 5, refer to P.182, 183.

• Dimensions of Driver, refer to P.46.

\*1 Motor specifications: □

\*2 The product that the end of driver model designation has "E" is "Position control type". Detail of model designation, refer to P.16.

\*3 ◇ in number of applicable driver represents the series. For more information about the part number, please refer to P.16.

Torque characteristics (at AC200 V of power voltage <Dotted line represents the torque at 10 % less supply voltage.>)

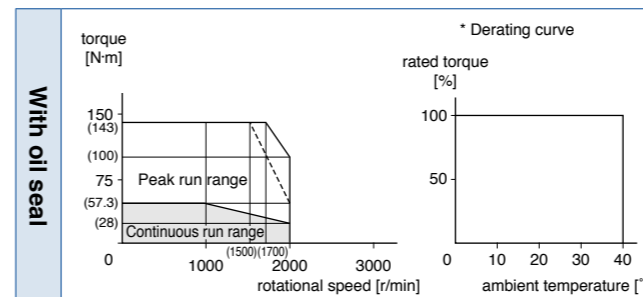

Dimensions

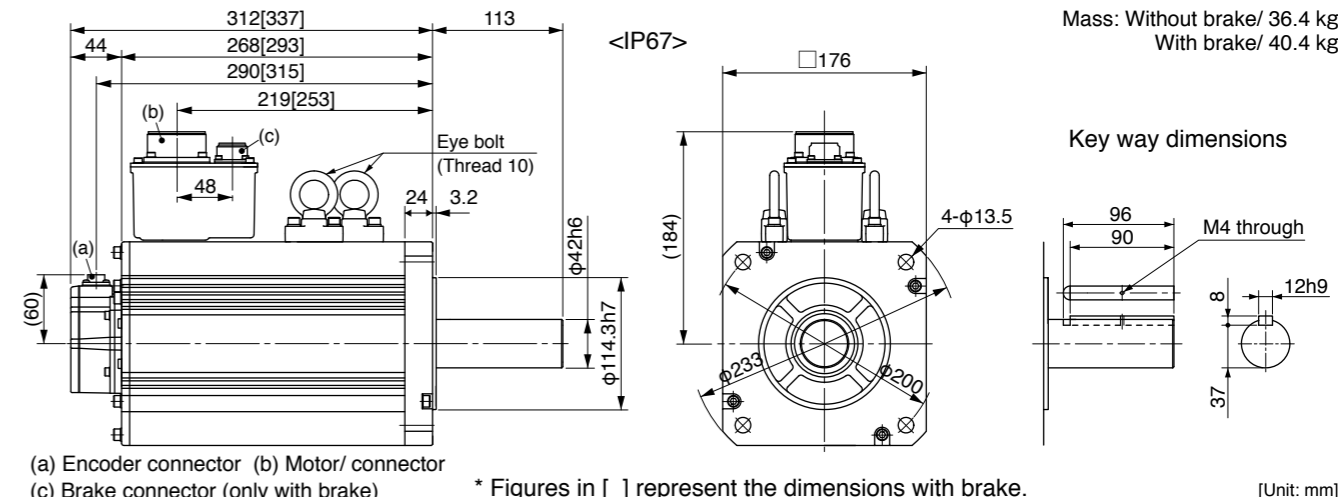

<Cautions> Reduce the moment of inertia ratio if high speed response operation is required. Dimensions are subject to change without notice. Contact us or a dealer for the latest information. Read the Instruction Manual carefully and understand all precautions and remarks before using the products.

Specifications

		AC200 V	
Motor model *1	IP65	MHME102GC□	MHME102SC□
	IP67	MHME102G1□	MHME102S1□
Applicable driver *2	Model No. A5II, A5 series	MDD◇T3530	
	A5IE, A5E series	MDD◇T3530E	-
Frame symbol		D-frame	
Power supply capacity (kVA)		1.8	
Rated output (W)		1000	
Rated torque (N·m)		4.77	
Momentary Max. peak torque (N·m)		14.3	
Rated current (A(rms))		5.7	
Max. current (A(o-p))		24	
Regenerative brake frequency (times/min) Note1	Without option	83	
	DV0P4284	No limit Note2	
Rated rotational speed (r/min)		2000	
Max. rotational speed (r/min)		3000	
Moment of inertia of rotor (×10 <sup>-4</sup> kg·m <sup>2</sup> )	Without brake	24.7	
	With brake	26.0	
Recommended moment of inertia ratio of the load and the rotor Note3		5 times or less	
Rotary encoder specifications Note5	20-bit Incremental		17-bit Absolute
	Resolution per single turn	1,048,576	131,072

• **Brake specifications** (For details, refer to P.183)  
 (This brake will be released when it is energized.)  
 (Do not use this for braking the motor in motion.)

Static friction torque (N·m)	4.9 or more
Engaging time (ms)	80 or less
Releasing time (ms) Note4	70 or less
Exciting current (DC) (A)	0.59±10 %
Releasing voltage (DC) (V)	2 or more
Exciting voltage (DC) (V)	24±2.4

• **Permissible load** (For details, refer to P.183)

During assembly	Radial load P-direction (N)	980
	Thrust load A-direction (N)	588
	Thrust load B-direction (N)	686
During operation	Radial load P-direction (N)	490
	Thrust load A, B-direction (N)	196

• For details of Note 1 to Note 5, refer to P.182, 183.

• Dimensions of Driver, refer to P.43.

\*1 Motor specifications: □

\*2 The product that the end of driver model designation has "E" is "Position control type". Detail of model designation, refer to P.16.

\*3 ◇ in number of applicable driver represents the series. For more information about the part number, please refer to P.16.

Torque characteristics (at AC200 V of power voltage <Dotted line represents the torque at 10 % less supply voltage.>)

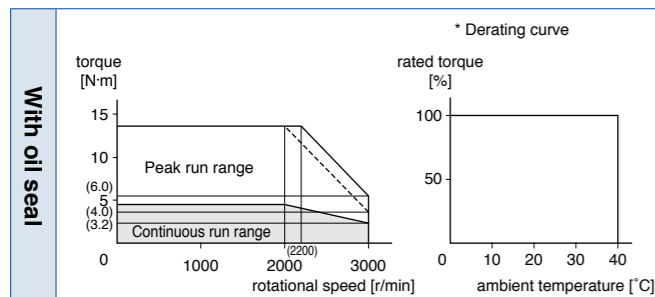

Dimensions

(For IP67 motor, refer to P.140.)

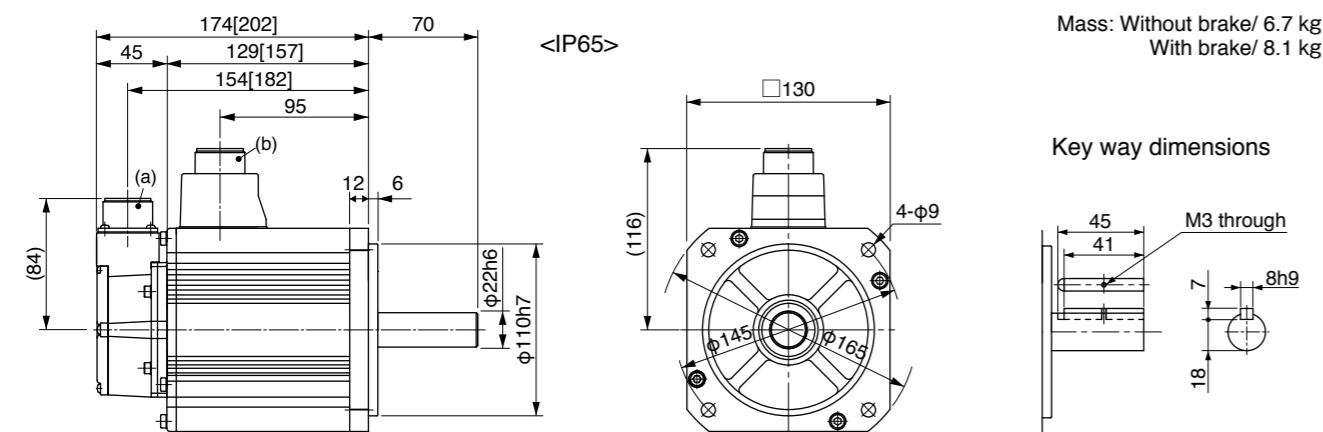

(a) Encoder connector  
 (b) Motor/Brake connector

\* Figures in [ ] represent the dimensions with brake.

[Unit: mm]

<Cautions> Reduce the moment of inertia ratio if high speed response operation is required. Dimensions are subject to change without notice. Contact us or a dealer for the latest information. Read the Instruction Manual carefully and understand all precautions and remarks before using the products.

Specifications

		AC200 V	
Motor model *1	IP65	MHME152GC□	MHME152SC□
	IP67	MHME152G1□	MHME152S1□
Applicable driver *2	Model No. A5II, A5 series	MDD◇T5540	
	A5IE, A5E series	MDD◇T5540E	-
Frame symbol		D-frame	
Power supply capacity (kVA)		2.3	
Rated output (W)		1500	
Rated torque (N·m)		7.16	
Momentary Max. peak torque (N·m)		21.5	
Rated current (A(rms))		9.4	
Max. current (A(o-p))		40	
Regenerative brake frequency (times/min) Note1	Without option	22	
	DV0P4284	130	
Rated rotational speed (r/min)		2000	
Max. rotational speed (r/min)		3000	
Moment of inertia of rotor (×10 <sup>-4</sup> kg·m <sup>2</sup> )	Without brake	37.1	
	With brake	38.4	
Recommended moment of inertia ratio of the load and the rotor Note3		5 times or less	
Rotary encoder specifications Note5	20-bit Incremental		17-bit Absolute
	Resolution per single turn	1,048,576	131,072

• **Brake specifications** (For details, refer to P.183)  
 (This brake will be released when it is energized.)  
 (Do not use this for braking the motor in motion.)

Static friction torque (N·m)	13.7 or more
Engaging time (ms)	100 or less
Releasing time (ms) Note4	50 or less
Exciting current (DC) (A)	0.79±10 %
Releasing voltage (DC) (V)	2 or more
Exciting voltage (DC) (V)	24±2.4

• **Permissible load** (For details, refer to P.183)

During assembly	Radial load P-direction (N)	980
	Thrust load A-direction (N)	588
	Thrust load B-direction (N)	686
During operation	Radial load P-direction (N)	490
	Thrust load A, B-direction (N)	196

• For details of Note 1 to Note 5, refer to P.182, 183.

• Dimensions of Driver, refer to P.43.

\*1 Motor specifications: □

\*2 The product that the end of driver model designation has "E" is "Position control type". Detail of model designation, refer to P.16.

\*3 ◇ in number of applicable driver represents the series. For more information about the part number, please refer to P.16.

Torque characteristics (at AC200 V of power voltage <Dotted line represents the torque at 10 % less supply voltage.>)

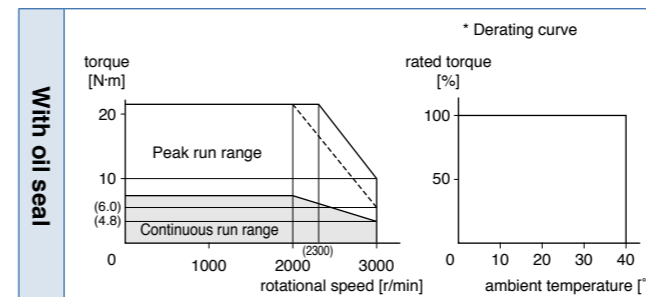

Dimensions

(For IP67 motor, refer to P.140.)

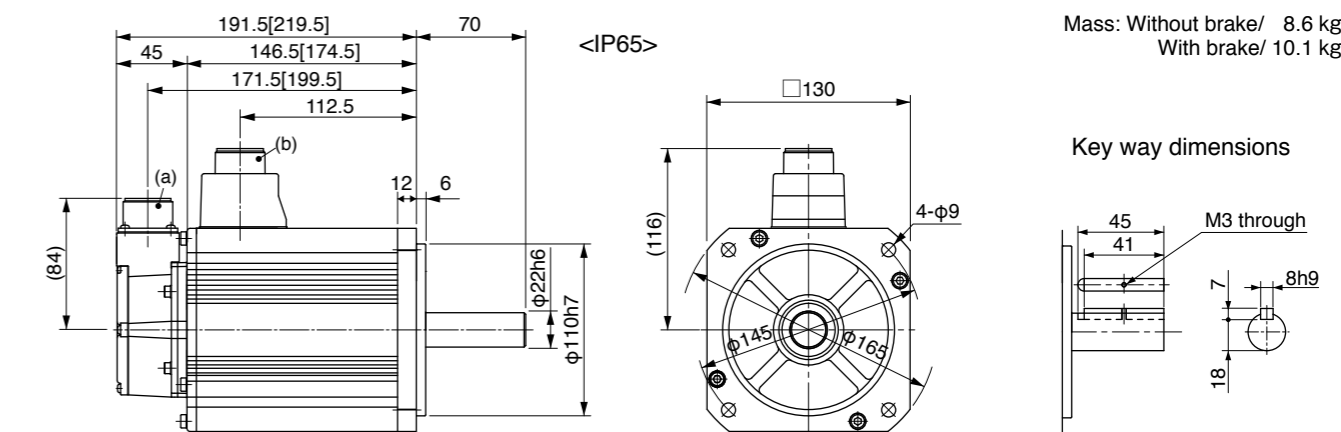

(a) Encoder connector  
 (b) Motor/Brake connector

\* Figures in [ ] represent the dimensions with brake.

[Unit: mm]

<Cautions> Reduce the moment of inertia ratio if high speed response operation is required. Dimensions are subject to change without notice. Contact us or a dealer for the latest information. Read the Instruction Manual carefully and understand all precautions and remarks before using the products.

Specifications

		AC200 V	
Motor model *1	IP65	MHME202GC□	MHME202SC□
	IP67	MHME202G1□	MHME202S1□
Applicable driver *2	Model No. A5II, A5 series	MED◇T7364	
	A5IE, A5E series	MED◇T7364E	-
Frame symbol		E-frame	
Power supply capacity (kVA)		3.3	
Rated output (W)		2000	
Rated torque (N·m)		9.55	
Momentary Max. peak torque (N·m)		28.6	
Rated current (A(rms))		11.1	
Max. current (A(o-p))		47	
Regenerative brake frequency (times/min) Note1	Without option	45	
	DV0P4285	142	
Rated rotational speed (r/min)		2000	
Max. rotational speed (r/min)		3000	
Moment of inertia of rotor (×10 <sup>-4</sup> kg·m <sup>2</sup> )	Without brake	57.8	
	With brake	59.6	
Recommended moment of inertia ratio of the load and the rotor Note3		5 times or less	
Rotary encoder specifications Note5	20-bit Incremental		17-bit Absolute
	Resolution per single turn	1,048,576	131,072

• **Brake specifications** (For details, refer to P.183)  
 (This brake will be released when it is energized.)  
 (Do not use this for braking the motor in motion.)

Static friction torque (N·m)	24.5 or more
Engaging time (ms)	80 or less
Releasing time (ms) Note4	25 or less
Exciting current (DC) (A)	1.3±10 %
Releasing voltage (DC) (V)	2 or more
Exciting voltage (DC) (V)	24±2.4

• **Permissible load** (For details, refer to P.183)

During assembly	Radial load P-direction (N)	1666
	Thrust load A-direction (N)	784
	Thrust load B-direction (N)	980
During operation	Radial load P-direction (N)	784
	Thrust load A, B-direction (N)	343

• For details of Note 1 to Note 5, refer to P.182, 183.

• Dimensions of Driver, refer to P.44.

\*1 Motor specifications: □

\*2 The product that the end of driver model designation has "E" is "Position control type". Detail of model designation, refer to P.16.

\*3 ◇ in number of applicable driver represents the series. For more information about the part number, please refer to P.16.

Torque characteristics (at AC200 V of power voltage <Dotted line represents the torque at 10 % less supply voltage.>)

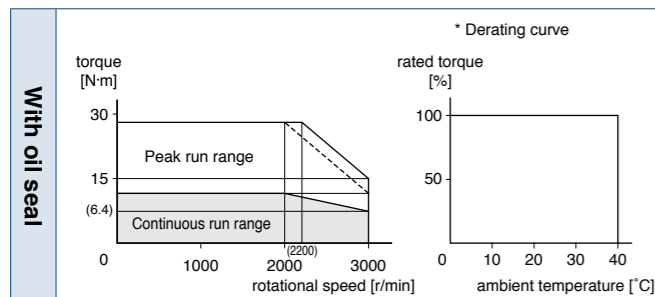

Dimensions

(For IP67 motor, refer to P.140.)

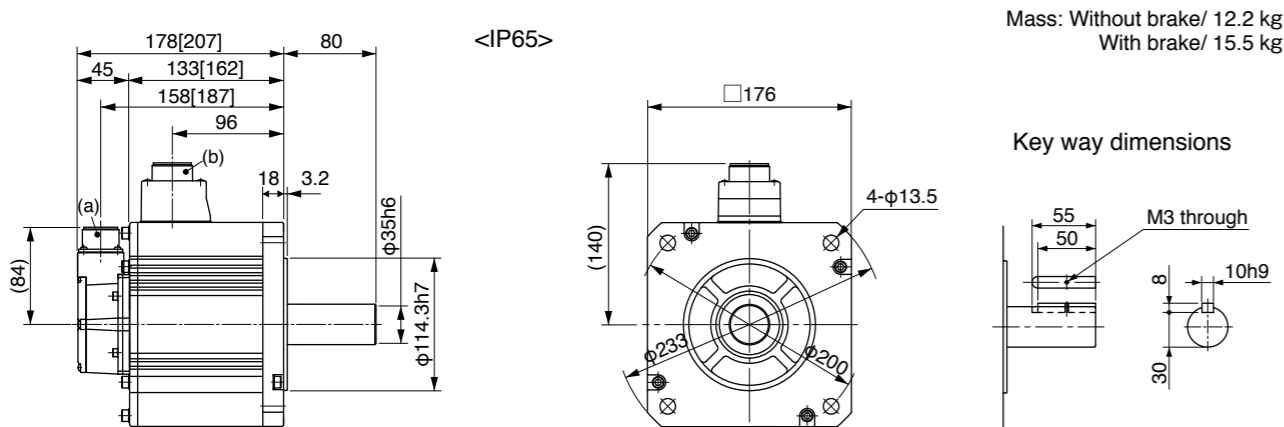

(a) Encoder connector  
 (b) Motor/Brake connector

\* Figures in [ ] represent the dimensions with brake.

[Unit: mm]

<Cautions> Reduce the moment of inertia ratio if high speed response operation is required. Dimensions are subject to change without notice. Contact us or a dealer for the latest information. Read the Instruction Manual carefully and understand all precautions and remarks before using the products.

Specifications

		AC200 V	
Motor model *1	IP65	MHME302GC□	MHME302SC□
	IP67	MHME302G1□	MHME302S1□
Applicable driver *2	Model No. A5II, A5 series	MFD◇TA390	
	A5IE, A5E series	MFD◇TA390E	-
Frame symbol		F-frame	
Power supply capacity (kVA)		4.5	
Rated output (W)		3000	
Rated torque (N·m)		14.3	
Momentary Max. peak torque (N·m)		43.0	
Rated current (A(rms))		16.0	
Max. current (A(o-p))		68	
Regenerative brake frequency (times/min) Note1	Without option	19	
	DV0P4285×2	142	
Rated rotational speed (r/min)		2000	
Max. rotational speed (r/min)		3000	
Moment of inertia of rotor (×10 <sup>-4</sup> kg·m <sup>2</sup> )	Without brake	90.5	
	With brake	92.1	
Recommended moment of inertia ratio of the load and the rotor Note3		5 times or less	
Rotary encoder specifications Note5	20-bit Incremental		17-bit Absolute
	Resolution per single turn	1,048,576	131,072

• **Brake specifications** (For details, refer to P.183)  
 (This brake will be released when it is energized.)  
 (Do not use this for braking the motor in motion.)

Static friction torque (N·m)	24.5 or more
Engaging time (ms)	80 or less
Releasing time (ms) Note4	25 or less
Exciting current (DC) (A)	1.3±10 %
Releasing voltage (DC) (V)	2 or more
Exciting voltage (DC) (V)	24±2.4

• **Permissible load** (For details, refer to P.183)

During assembly	Radial load P-direction (N)	1666
	Thrust load A-direction (N)	784
	Thrust load B-direction (N)	980
During operation	Radial load P-direction (N)	784
	Thrust load A, B-direction (N)	343

• For details of Note 1 to Note 5, refer to P.182, 183.

• Dimensions of Driver, refer to P.45.

\*1 Motor specifications: □

\*2 The product that the end of driver model designation has "E" is "Position control type". Detail of model designation, refer to P.16.

\*3 ◇ in number of applicable driver represents the series. For more information about the part number, please refer to P.16.

Torque characteristics (at AC200 V of power voltage <Dotted line represents the torque at 10 % less supply voltage.>)

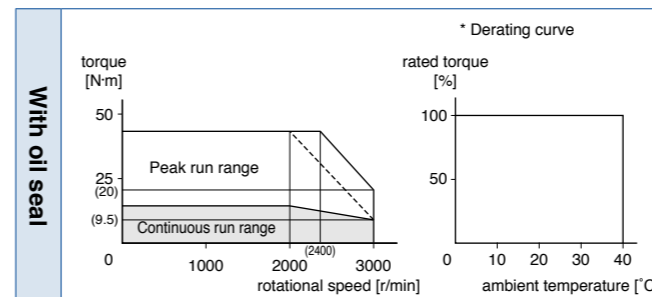

Dimensions

(For IP67 motor, refer to P.140.)

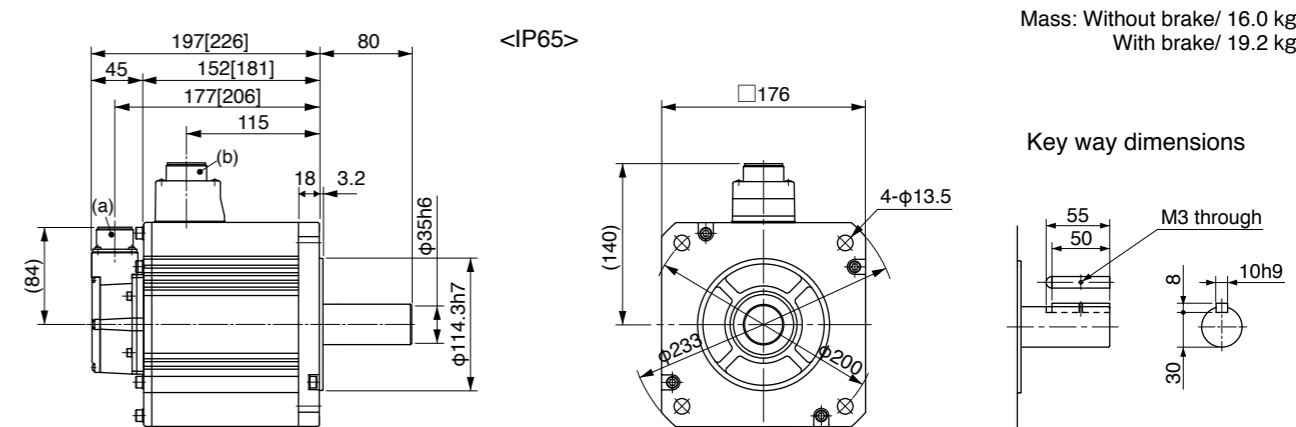

(a) Encoder connector  
 (b) Motor/Brake connector

\* Figures in [ ] represent the dimensions with brake.

[Unit: mm]

<Cautions> Reduce the moment of inertia ratio if high speed response operation is required. Dimensions are subject to change without notice. Contact us or a dealer for the latest information. Read the Instruction Manual carefully and understand all precautions and remarks before using the products.

Specifications

		AC200 V	
Motor model *1	IP65	MHME402GC□	MHME402SC□
	IP67	MHME402G1□	MHME402S1□
Applicable driver *2	Model No. A5II, A5 series	MFD◇TB3A2	
	A5IE, A5E series	MFD◇TB3A2E	-
Frame symbol		F-frame	
Power supply capacity (kVA)		6.0	
Rated output (W)		4000	
Rated torque (N·m)		19.1	
Momentary Max. peak torque (N·m)		57.3	
Rated current (A(rms))		21.0	
Max. current (A(o-p))		89	
Regenerative brake frequency (times/min) Note1	Without option	17	
	DV0P4285×2	125	
Rated rotational speed (r/min)		2000	
Max. rotational speed (r/min)		3000	
Moment of inertia of rotor (×10 <sup>-4</sup> kg·m <sup>2</sup> )	Without brake	112	
	With brake	114	
Recommended moment of inertia ratio of the load and the rotor Note3		5 times or less	
Rotary encoder specifications Note5	20-bit Incremental		17-bit Absolute
	Resolution per single turn	1,048,576	131,072

• **Brake specifications** (For details, refer to P.183)  
 (This brake will be released when it is energized.)  
 (Do not use this for braking the motor in motion.)

Static friction torque (N·m)	24.5 or more
Engaging time (ms)	80 or less
Releasing time (ms) Note4	25 or less
Exciting current (DC) (A)	1.3±10 %
Releasing voltage (DC) (V)	2 or more
Exciting voltage (DC) (V)	24±2.4

• **Permissible load** (For details, refer to P.183)

During assembly	Radial load P-direction (N)	1666
	Thrust load A-direction (N)	784
	Thrust load B-direction (N)	980
During operation	Radial load P-direction (N)	784
	Thrust load A, B-direction (N)	343

• For details of Note 1 to Note 5, refer to P.182, 183.

• Dimensions of Driver, refer to P.45.

\*1 Motor specifications: □

\*2 The product that the end of driver model designation has "E" is "Position control type". Detail of model designation, refer to P.16.

\*3 ◇ in number of applicable driver represents the series. For more information about the part number, please refer to P.16.

Torque characteristics (at AC200 V of power voltage <Dotted line represents the torque at 10 % less supply voltage.>)

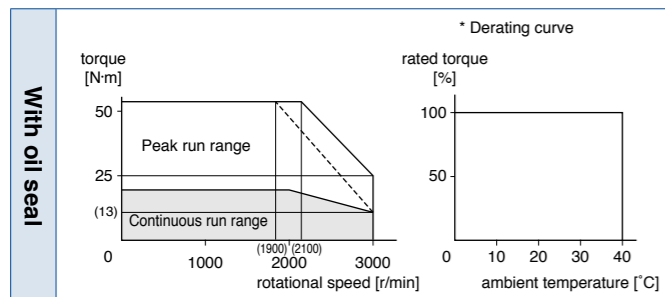

Dimensions

(For IP67 motor, refer to P.140.)

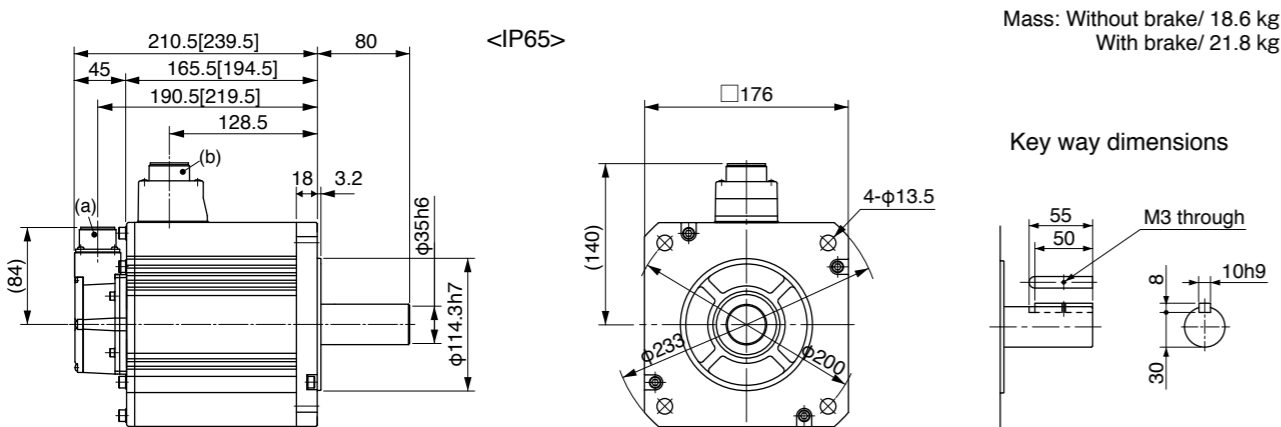

(a) Encoder connector  
 (b) Motor/Brake connector

\* Figures in [ ] represent the dimensions with brake.

[Unit: mm]

<Cautions> Reduce the moment of inertia ratio if high speed response operation is required. Dimensions are subject to change without notice. Contact us or a dealer for the latest information. Read the Instruction Manual carefully and understand all precautions and remarks before using the products.

Specifications

		AC200 V	
Motor model *1	IP65	MHME502GC□	MHME502SC□
	IP67	MHME502G1□	MHME502S1□
Applicable driver *2	Model No. A5II, A5 series	MFD◇TB3A2	
	A5IE, A5E series	MFD◇TB3A2E	-
Frame symbol		F-frame	
Power supply capacity (kVA)		7.5	
Rated output (W)		5000	
Rated torque (N·m)		23.9	
Momentary Max. peak torque (N·m)		71.6	
Rated current (A(rms))		25.9	
Max. current (A(o-p))		110	
Regenerative brake frequency (times/min) Note1	Without option	10	
	DV0P4285×2	76	
Rated rotational speed (r/min)		2000	
Max. rotational speed (r/min)		3000	
Moment of inertia of rotor (×10 <sup>-4</sup> kg·m <sup>2</sup> )	Without brake	162	
	With brake	164	
Recommended moment of inertia ratio of the load and the rotor Note3		5 times or less	
Rotary encoder specifications Note5	20-bit Incremental		17-bit Absolute
	Resolution per single turn	1,048,576	131,072

• **Brake specifications** (For details, refer to P.183)  
 (This brake will be released when it is energized.)  
 (Do not use this for braking the motor in motion.)

Static friction torque (N·m)	24.5 or more
Engaging time (ms)	80 or less
Releasing time (ms) Note4	25 or less
Exciting current (DC) (A)	1.3±10 %
Releasing voltage (DC) (V)	2 or more
Exciting voltage (DC) (V)	24±2.4

• **Permissible load** (For details, refer to P.183)

During assembly	Radial load P-direction (N)	1666
	Thrust load A-direction (N)	784
	Thrust load B-direction (N)	980
During operation	Radial load P-direction (N)	784
	Thrust load A, B-direction (N)	343

• For details of Note 1 to Note 5, refer to P.182, 183.

• Dimensions of Driver, refer to P.45.

\*1 Motor specifications: □

\*2 The product that the end of driver model designation has "E" is "Position control type". Detail of model designation, refer to P.16.

\*3 ◇ in number of applicable driver represents the series. For more information about the part number, please refer to P.16.

Torque characteristics (at AC200 V of power voltage <Dotted line represents the torque at 10 % less supply voltage.>)

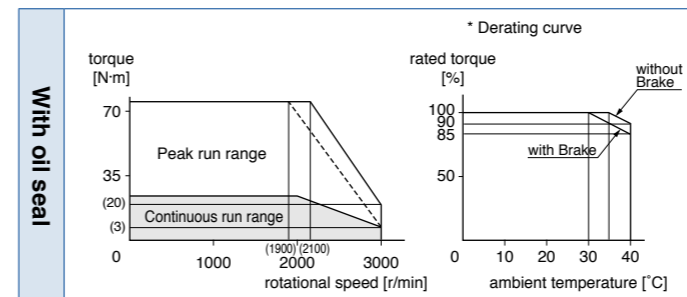

Dimensions

(For IP67 motor, refer to P.140.)

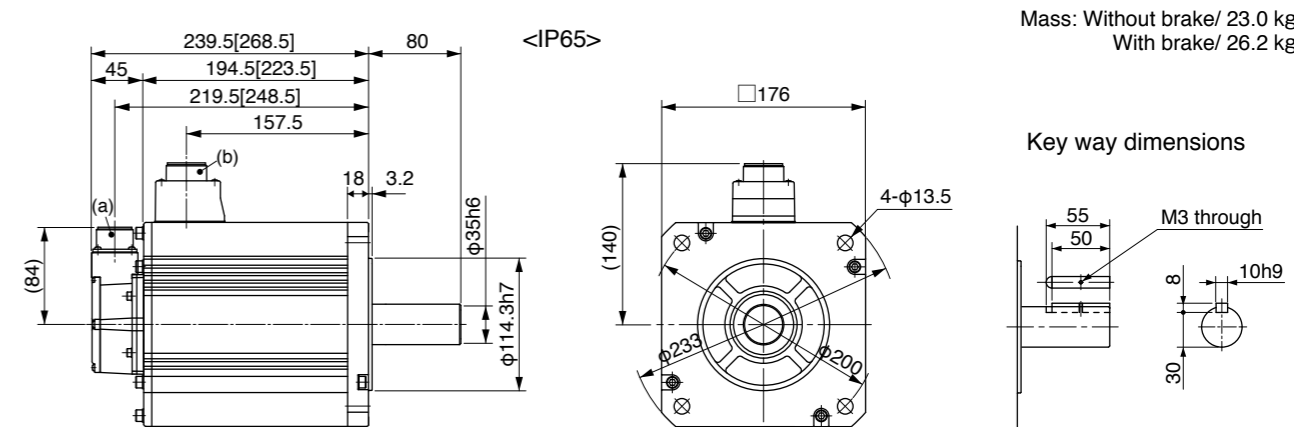

(a) Encoder connector  
 (b) Motor/Brake connector

\* Figures in [ ] represent the dimensions with brake.

[Unit: mm]

<Cautions> Reduce the moment of inertia ratio if high speed response operation is required. Dimensions are subject to change without notice. Contact us or a dealer for the latest information. Read the Instruction Manual carefully and understand all precautions and remarks before using the products.

Specifications

		AC200 V	
Motor model *1	IP65	-	-
	IP67	MHME752G1□	MHME752S1□
Applicable driver *2	Model No.	A5II, A5 series	MGD◇TC3B4
		A5IE, A5E series	-
Frame symbol		G-frame	
Power supply capacity (kVA)	11		
Rated output (W)	7500		
Rated torque (N·m)	47.8		
Momentary Max. peak torque (N·m)	119		
Rated current (A(rms))	44.0		
Max. current (A(o-p))	165		
Regenerative brake frequency (times/min) Note1	Without option	No limit Note2	
	DV0P4285×4	No limit Note2	
Rated rotational speed (r/min)	1500		
Max. rotational speed (r/min)	3000		
Moment of inertia of rotor (×10 <sup>-4</sup> kg·m <sup>2</sup> )	Without brake	273	
	With brake	279	
Recommended moment of inertia ratio of the load and the rotor Note3	5 times or less		
Rotary encoder specifications Note5	20-bit Incremental	1,048,576	17-bit Absolute
	Resolution per single turn	1,048,576	131,072

• **Brake specifications** (For details, refer to P.183)  
 (This brake will be released when it is energized.)  
 (Do not use this for braking the motor in motion.)

Static friction torque (N·m)	58.8 or more
Engaging time (ms)	150 or less
Releasing time (ms) Note4	50 or less
Exciting current (DC) (A)	1.41±10 %
Releasing voltage (DC) (V)	2 or more
Exciting voltage (DC) (V)	24±2.4

• **Permissible load** (For details, refer to P.183)

During assembly	Radial load P-direction (N)	2058
	Thrust load A-direction (N)	980
	Thrust load B-direction (N)	1176
During operation	Radial load P-direction (N)	1176
	Thrust load A, B-direction (N)	490

• For details of Note 1 to Note 5, refer to P.182, 183.

• Dimensions of Driver, refer to P.46.

\*1 Motor specifications: □

\*2 The product that the end of driver model designation has "E" is "Position control type". Detail of model designation, refer to P.16.

\*3 ◇ in number of applicable driver represents the series. For more information about the part number, please refer to P.16.

Torque characteristics (at AC200 V of power voltage <Dotted line represents the torque at 10 % less supply voltage.>)

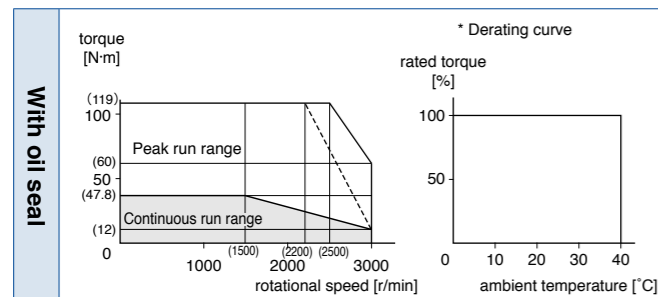

Dimensions

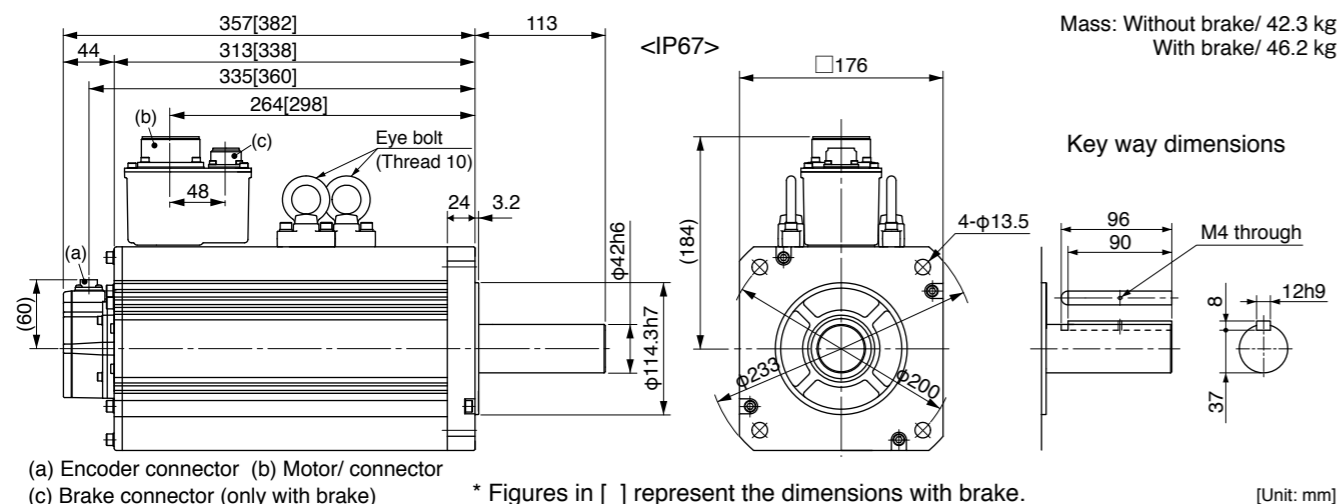

<Cautions> Reduce the moment of inertia ratio if high speed response operation is required. Dimensions are subject to change without notice. Contact us or a dealer for the latest information. Read the Instruction Manual carefully and understand all precautions and remarks before using the products.

Specifications

		AC400 V	
Motor model *1	IP65	MSME084GC□	MSME084SC□
	IP67	MSME084G1□	MSME084S1□
Applicable driver *2	Model No.	A5II, A5 series	MDD◇T2412
		A5IE, A5E series	MDD◇T2412E
Frame symbol		D-frame	
Power supply capacity (kVA)	1.6		
Rated output (W)	750		
Rated torque (N·m)	2.39		
Momentary Max. peak torque (N·m)	7.16		
Rated current (A(rms))	2.4		
Max. current (A(o-p))	10		
Regenerative brake frequency (times/min) Note1	Without option	No limit Note2	
	DV0PM20048	No limit Note2	
Rated rotational speed (r/min)	3000		
Max. rotational speed (r/min)	5000		
Moment of inertia of rotor (×10 <sup>-4</sup> kg·m <sup>2</sup> )	Without brake	1.61	
	With brake	1.93	
Recommended moment of inertia ratio of the load and the rotor Note3	15 times or less		
Rotary encoder specifications Note5	20-bit Incremental	1,048,576	17-bit Absolute
	Resolution per single turn	1,048,576	131,072

• **Brake specifications** (For details, refer to P.183)  
 (This brake will be released when it is energized.)  
 (Do not use this for braking the motor in motion.)

Static friction torque (N·m)	2.5 or more
Engaging time (ms)	50 or less
Releasing time (ms) Note4	15 or less
Exciting current (DC) (A)	0.70±10 %
Releasing voltage (DC) (V)	2 or more
Exciting voltage (DC) (V)	24±2.4

• **Permissible load** (For details, refer to P.183)

During assembly	Radial load P-direction (N)	980
	Thrust load A-direction (N)	588
	Thrust load B-direction (N)	686
During operation	Radial load P-direction (N)	490
	Thrust load A, B-direction (N)	196

• For details of Note 1 to Note 5, refer to P.182, 183.

• Dimensions of Driver, refer to P.44.

\*1 Motor specifications: □

\*2 The product that the end of driver model designation has "E" is "Position control type". Detail of model designation, refer to P.16.

\*3 ◇ in number of applicable driver represents the series. For more information about the part number, please refer to P.16.

Torque characteristics (at AC400 V of power voltage <Dotted line represents the torque at 10 % less supply voltage.>)

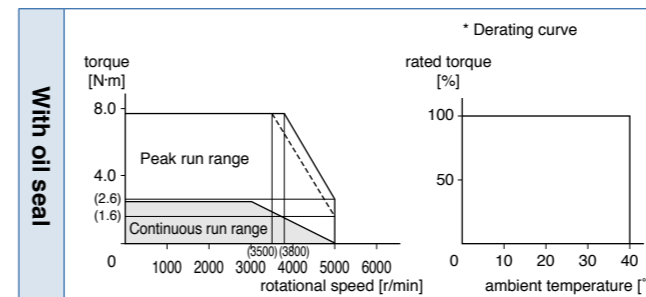

Dimensions

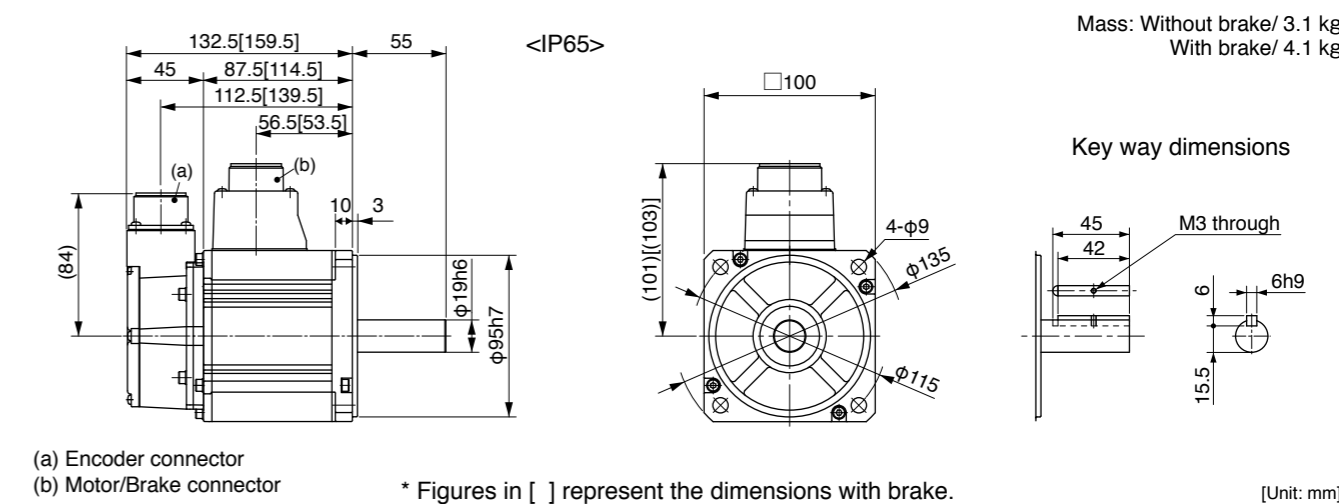

<Cautions> Reduce the moment of inertia ratio if high speed response operation is required. Dimensions are subject to change without notice. Contact us or a dealer for the latest information. Read the Instruction Manual carefully and understand all precautions and remarks before using the products.

Specifications

		AC400 V	
Motor model *1	IP65	MSME104GC□	MSME104SC□
	IP67	MSME104G1□	MSME104S1□
Applicable driver *2	Model No.	A5II, A5 series	MDD◇T3420
	A5IE, A5E series	MDD◇T3420E	-
Frame symbol		D-frame	
Power supply capacity (kVA)	1.8		
Rated output (W)	1000		
Rated torque (N·m)	3.18		
Momentary Max. peak torque (N·m)	9.55		
Rated current (A(rms))	3.3		
Max. current (A(o-p))	14		
Regenerative brake frequency (times/min) Note1	Without option	No limit Note2	
	DV0PM20048	No limit Note2	
Rated rotational speed (r/min)	3000		
Max. rotational speed (r/min)	5000		
Moment of inertia of rotor ( $\times 10^{-4}$ kg·m <sup>2</sup> )	Without brake	2.03	
	With brake	2.35	
Recommended moment of inertia ratio of the load and the rotor Note3	15 times or less		
Rotary encoder specifications Note5	20-bit Incremental	17-bit Absolute	
	Resolution per single turn	1,048,576	131,072

• **Brake specifications** (For details, refer to P.183)  
 (This brake will be released when it is energized.)  
 (Do not use this for braking the motor in motion.)

Static friction torque (N·m)	7.8 or more
Engaging time (ms)	50 or less
Releasing time (ms) Note4	15 or less
Exciting current (DC) (A)	0.81±10 %
Releasing voltage (DC) (V)	2 or more
Exciting voltage (DC) (V)	24±2.4

• **Permissible load** (For details, refer to P.183)

During assembly	Radial load P-direction (N)	980
	Thrust load A-direction (N)	588
	Thrust load B-direction (N)	686
During operation	Radial load P-direction (N)	490
	Thrust load A, B-direction (N)	196

• For details of Note 1 to Note 5, refer to P.182, 183.  
 • Dimensions of Driver, refer to P.44.

- \*1 Motor specifications: □
- \*2 The product that the end of driver model designation has "E" is "Position control type". Detail of model designation, refer to P.16.
- \*3 ◇ in number of applicable driver represents the series. For more information about the part number, please refer to P.16.

Torque characteristics (at AC400 V of power voltage <Dotted line represents the torque at 10 % less supply voltage.>)

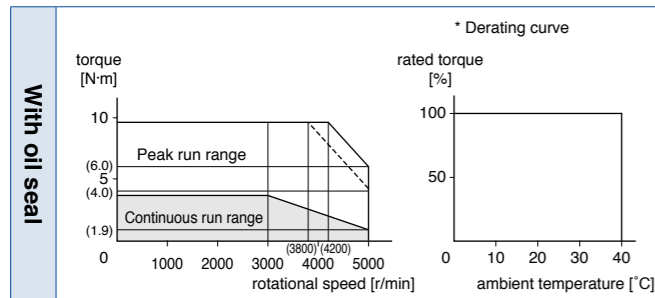

Dimensions

(For IP67 motor, refer to P.137.)

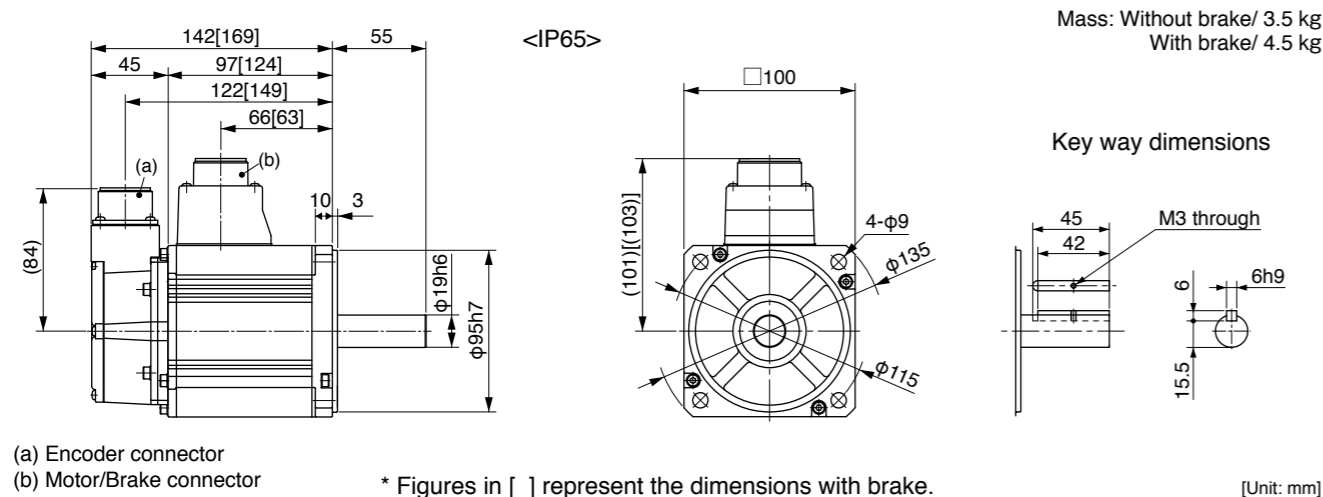

(a) Encoder connector  
 (b) Motor/Brake connector  
 \* Figures in [ ] represent the dimensions with brake.  
 <Cautions> Reduce the moment of inertia ratio if high speed response operation is required. Dimensions are subject to change without notice. Contact us or a dealer for the latest information. Read the Instruction Manual carefully and understand all precautions and remarks before using the products.

Specifications

		AC400 V	
Motor model *1	IP65	MSME154GC□	MSME154SC□
	IP67	MSME154G1□	MSME154S1□
Applicable driver *2	Model No.	A5II, A5 series	MDD◇T3420
	A5IE, A5E series	MDD◇T3420E	-
Frame symbol		D-frame	
Power supply capacity (kVA)	2.3		
Rated output (W)	1500		
Rated torque (N·m)	4.77		
Momentary Max. peak torque (N·m)	14.3		
Rated current (A(rms))	4.2		
Max. current (A(o-p))	18		
Regenerative brake frequency (times/min) Note1	Without option	No limit Note2	
	DV0PM20048	No limit Note2	
Rated rotational speed (r/min)	3000		
Max. rotational speed (r/min)	5000		
Moment of inertia of rotor ( $\times 10^{-4}$ kg·m <sup>2</sup> )	Without brake	2.84	
	With brake	3.17	
Recommended moment of inertia ratio of the load and the rotor Note3	15 times or less		
Rotary encoder specifications Note5	20-bit Incremental	17-bit Absolute	
	Resolution per single turn	1,048,576	131,072

• **Brake specifications** (For details, refer to P.183)  
 (This brake will be released when it is energized.)  
 (Do not use this for braking the motor in motion.)

Static friction torque (N·m)	7.8 or more
Engaging time (ms)	50 or less
Releasing time (ms) Note4	15 or less
Exciting current (DC) (A)	0.81±10 %
Releasing voltage (DC) (V)	2 or more
Exciting voltage (DC) (V)	24±2.4

• **Permissible load** (For details, refer to P.183)

During assembly	Radial load P-direction (N)	980
	Thrust load A-direction (N)	588
	Thrust load B-direction (N)	686
During operation	Radial load P-direction (N)	490
	Thrust load A, B-direction (N)	196

• For details of Note 1 to Note 5, refer to P.182, 183.  
 • Dimensions of Driver, refer to P.44.

- \*1 Motor specifications: □
- \*2 The product that the end of driver model designation has "E" is "Position control type". Detail of model designation, refer to P.16.
- \*3 ◇ in number of applicable driver represents the series. For more information about the part number, please refer to P.16.

Torque characteristics (at AC400 V of power voltage <Dotted line represents the torque at 10 % less supply voltage.>)

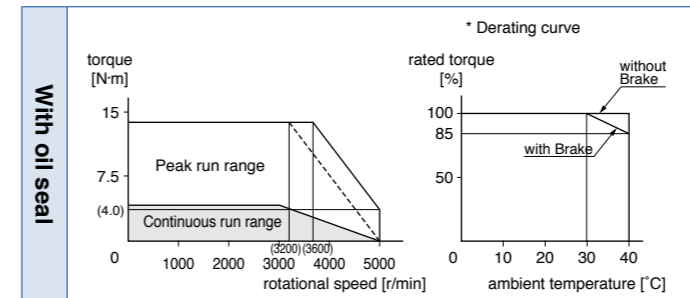

Dimensions

(For IP67 motor, refer to P.137.)

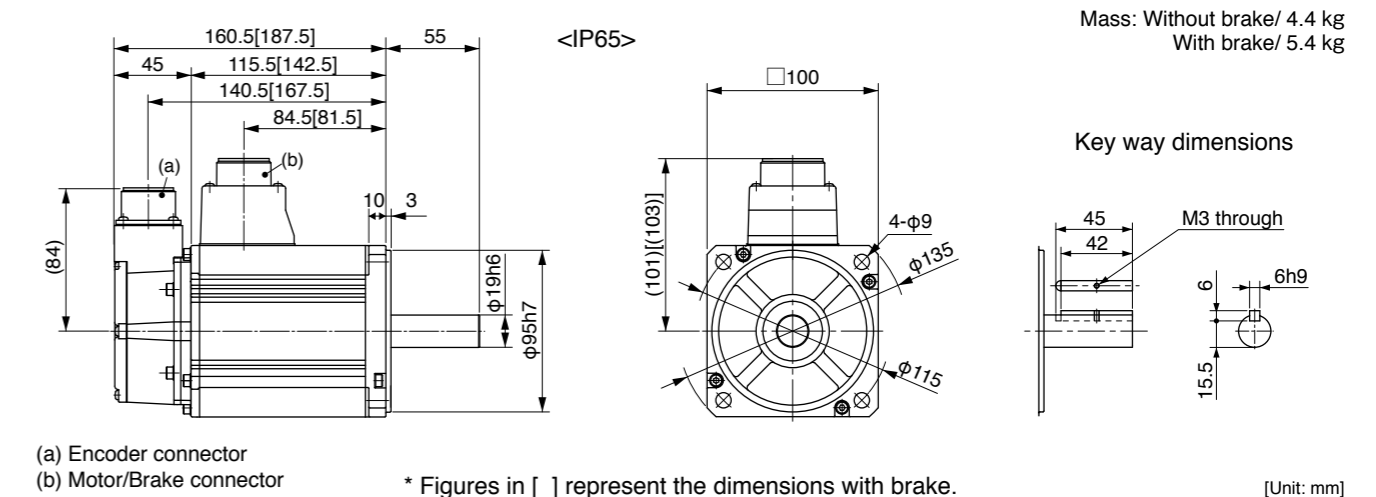

(a) Encoder connector  
 (b) Motor/Brake connector  
 \* Figures in [ ] represent the dimensions with brake.  
 <Cautions> Reduce the moment of inertia ratio if high speed response operation is required. Dimensions are subject to change without notice. Contact us or a dealer for the latest information. Read the Instruction Manual carefully and understand all precautions and remarks before using the products.

Specifications

		AC400 V	
Motor model *1	IP65	MSME204GC□	MSME204SC□
	IP67	MSME204G1□	MSME204S1□
Applicable driver *2	Model No. A5I, A5 series	MED◇T4430	
	A5IE, A5E series	MED◇T4430E	-
Frame symbol		E-frame	
Power supply capacity (kVA)		3.3	
Rated output (W)		2000	
Rated torque (N·m)		6.37	
Momentary Max. peak torque (N·m)		19.1	
Rated current (A(rms))		5.7	
Max. current (A(o-p))		24	
Regenerative brake frequency (times/min) Note1	Without option	No limit Note2	
	DV0PM20049	No limit Note2	
Rated rotational speed (r/min)		3000	
Max. rotational speed (r/min)		5000	
Moment of inertia of rotor (x10 <sup>-4</sup> kg·m <sup>2</sup> )	Without brake	3.68	
	With brake	4.01	
Recommended moment of inertia ratio of the load and the rotor Note3		15 times or less	
Rotary encoder specifications Note5	20-bit Incremental		17-bit Absolute
	Resolution per single turn	1,048,576	131,072

• **Brake specifications** (For details, refer to P.183)  
 (This brake will be released when it is energized.)  
 (Do not use this for braking the motor in motion.)

Static friction torque (N·m)	7.8 or more
Engaging time (ms)	50 or less
Releasing time (ms) Note4	15 or less
Exciting current (DC) (A)	0.81±10 %
Releasing voltage (DC) (V)	2 or more
Exciting voltage (DC) (V)	24±2.4

• **Permissible load** (For details, refer to P.183)

During assembly	Radial load P-direction (N)	980
	Thrust load A-direction (N)	588
	Thrust load B-direction (N)	686
During operation	Radial load P-direction (N)	490
	Thrust load A, B-direction (N)	196

• For details of Note 1 to Note 5, refer to P.182, 183.  
 • Dimensions of Driver, refer to P.45.

- \*1 Motor specifications: □
- \*2 The product that the end of driver model designation has "E" is "Position control type". Detail of model designation, refer to P.16.
- \*3 ◇ in number of applicable driver represents the series. For more information about the part number, please refer to P.16.

Torque characteristics (at AC400 V of power voltage <Dotted line represents the torque at 10 % less supply voltage.>)

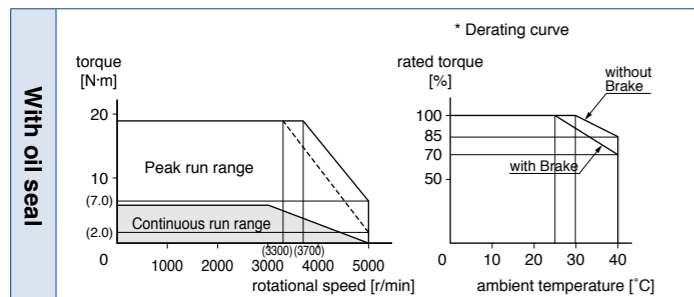

Dimensions

(For IP67 motor, refer to P.137.)

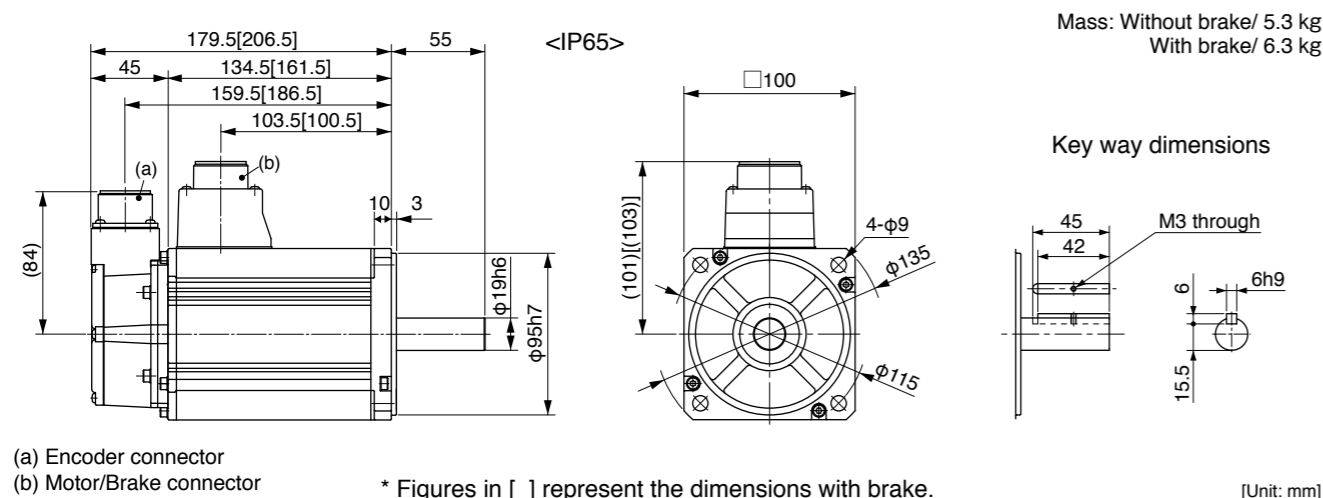

(a) Encoder connector  
 (b) Motor/Brake connector  
 \* Figures in [ ] represent the dimensions with brake.  
 <Cautions> Reduce the moment of inertia ratio if high speed response operation is required. Dimensions are subject to change without notice. Contact us or a dealer for the latest information. Read the Instruction Manual carefully and understand all precautions and remarks before using the products.

Specifications

		AC400 V	
Motor model *1	IP65	MSME304GC□	MSME304SC□
	IP67	MSME304G1□	MSME304S1□
Applicable driver *2	Model No. A5I, A5 series	MFD◇T5440	
	A5IE, A5E series	MFD◇T5440E	-
Frame symbol		F-frame	
Power supply capacity (kVA)		4.5	
Rated output (W)		3000	
Rated torque (N·m)		9.55	
Momentary Max. peak torque (N·m)		28.6	
Rated current (A(rms))		9.2	
Max. current (A(o-p))		39	
Regenerative brake frequency (times/min) Note1	Without option	No limit Note2	
	DV0PM20049x2	No limit Note2	
Rated rotational speed (r/min)		3000	
Max. rotational speed (r/min)		5000	
Moment of inertia of rotor (x10 <sup>-4</sup> kg·m <sup>2</sup> )	Without brake	6.50	
	With brake	7.85	
Recommended moment of inertia ratio of the load and the rotor Note3		15 times or less	
Rotary encoder specifications Note5	20-bit Incremental		17-bit Absolute
	Resolution per single turn	1,048,576	131,072

• **Brake specifications** (For details, refer to P.183)  
 (This brake will be released when it is energized.)  
 (Do not use this for braking the motor in motion.)

Static friction torque (N·m)	11.8 or more
Engaging time (ms)	80 or less
Releasing time (ms) Note4	15 or less
Exciting current (DC) (A)	0.81±10 %
Releasing voltage (DC) (V)	2 or more
Exciting voltage (DC) (V)	24±2.4

• **Permissible load** (For details, refer to P.183)

During assembly	Radial load P-direction (N)	980
	Thrust load A-direction (N)	588
	Thrust load B-direction (N)	686
During operation	Radial load P-direction (N)	490
	Thrust load A, B-direction (N)	196

• For details of Note 1 to Note 5, refer to P.182, 183.  
 • Dimensions of Driver, refer to P.45.

- \*1 Motor specifications: □
- \*2 The product that the end of driver model designation has "E" is "Position control type". Detail of model designation, refer to P.16.
- \*3 ◇ in number of applicable driver represents the series. For more information about the part number, please refer to P.16.

Torque characteristics (at AC400 V of power voltage <Dotted line represents the torque at 10 % less supply voltage.>)

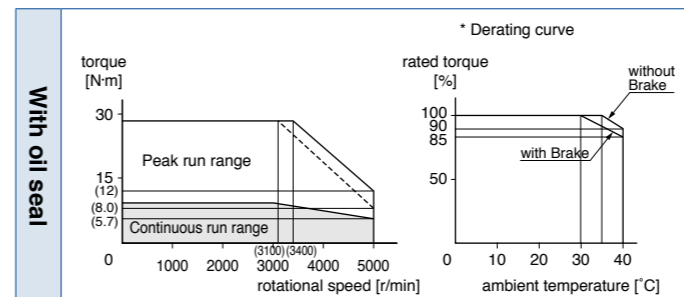

Dimensions

(For IP67 motor, refer to P.137.)

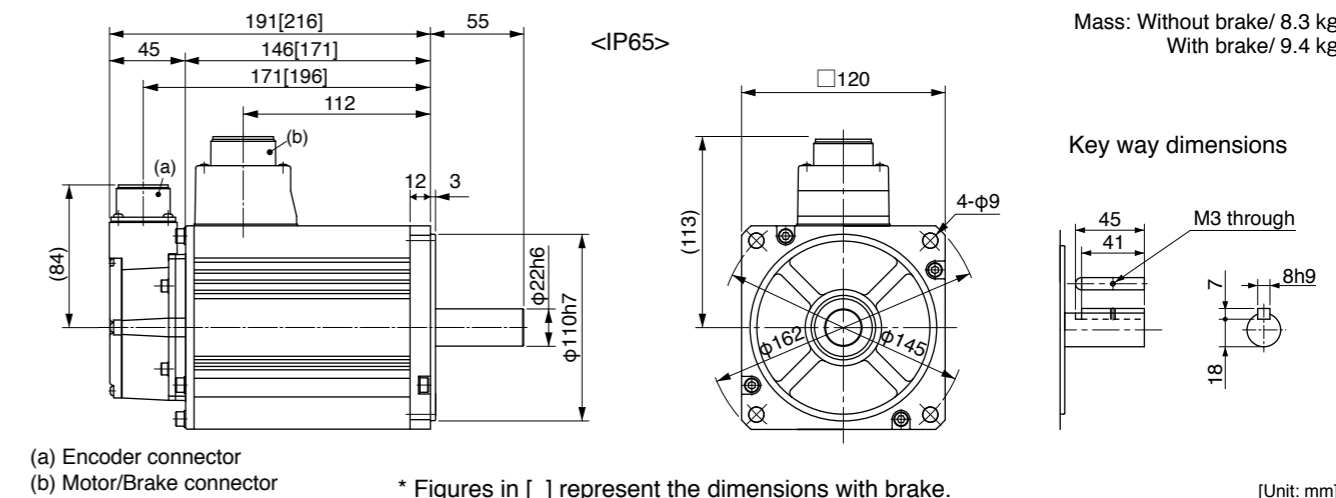

(a) Encoder connector  
 (b) Motor/Brake connector  
 \* Figures in [ ] represent the dimensions with brake.  
 <Cautions> Reduce the moment of inertia ratio if high speed response operation is required. Dimensions are subject to change without notice. Contact us or a dealer for the latest information. Read the Instruction Manual carefully and understand all precautions and remarks before using the products.

Specifications

		AC400 V	
Motor model *1	IP65	MSME404GC□	MSME404SC□
	IP67	MSME404G1□	MSME404S1□
Applicable driver *2	Model No. A5II, A5 series	MFD◇TA464	
	A5IE, A5E series	MFD◇TA464E	-
Frame symbol		F-frame	
Power supply capacity (kVA)	6.8		
Rated output (W)	4000		
Rated torque (N·m)	12.7		
Momentary Max. peak torque (N·m)	38.2		
Rated current (A(rms))	9.9		
Max. current (A(o-p))	42		
Regenerative brake frequency (times/min) Note1	Without option	No limit Note2	
	DV0PM20049x2	No limit Note2	
Rated rotational speed (r/min)	3000		
Max. rotational speed (r/min)	4500		
Moment of inertia of rotor (x10 <sup>-4</sup> kg·m <sup>2</sup> )	Without brake	12.9	
	With brake	14.2	
Recommended moment of inertia ratio of the load and the rotor Note3	15 times or less		
Rotary encoder specifications Note5	20-bit Incremental	17-bit Absolute	
	Resolution per single turn	1,048,576	131,072

• **Brake specifications** (For details, refer to P.183)  
 (This brake will be released when it is energized.)  
 (Do not use this for braking the motor in motion.)

Static friction torque (N·m)	16.2 or more
Engaging time (ms)	110 or less
Releasing time (ms) Note4	50 or less
Exciting current (DC) (A)	0.90±10 %
Releasing voltage (DC) (V)	2 or more
Exciting voltage (DC) (V)	24±2.4

• **Permissible load** (For details, refer to P.183)

During assembly	Radial load P-direction (N)	980
	Thrust load A-direction (N)	588
	Thrust load B-direction (N)	686
During operation	Radial load P-direction (N)	784
	Thrust load A, B-direction (N)	343

• For details of Note 1 to Note 5, refer to P.182, 183.  
 • Dimensions of Driver, refer to P.45.

- \*1 Motor specifications: □
- \*2 The product that the end of driver model designation has "E" is "Position control type". Detail of model designation, refer to P.16.
- \*3 ◇ in number of applicable driver represents the series. For more information about the part number, please refer to P.16.

Torque characteristics (at AC400 V of power voltage <Dotted line represents the torque at 10 % less supply voltage.>)

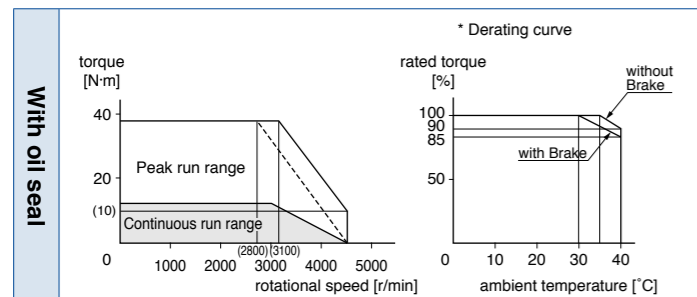

Dimensions

(For IP67 motor, refer to P.137.)

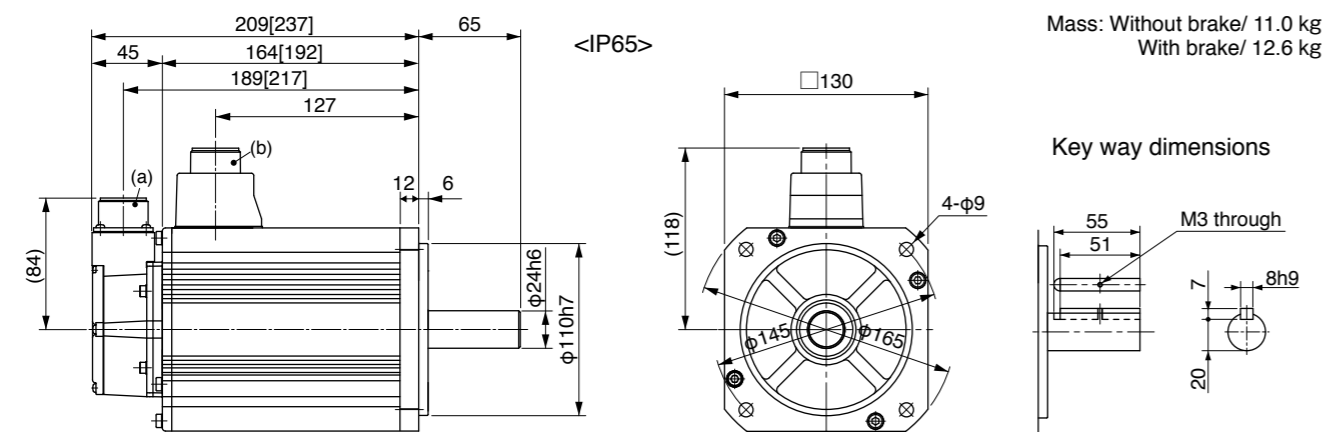

(a) Encoder connector  
 (b) Motor/Brake connector

\* Figures in [ ] represent the dimensions with brake.

[Unit: mm]

<Cautions> Reduce the moment of inertia ratio if high speed response operation is required. Dimensions are subject to change without notice. Contact us or a dealer for the latest information. Read the Instruction Manual carefully and understand all precautions and remarks before using the products.

Specifications

		AC400 V	
Motor model *1	IP65	MSME504GC□	MSME504SC□
	IP67	MSME504G1□	MSME504S1□
Applicable driver *2	Model No. A5II, A5 series	MFD◇TA464	
	A5IE, A5E series	MFD◇TA464E	-
Frame symbol		F-frame	
Power supply capacity (kVA)	7.5		
Rated output (W)	5000		
Rated torque (N·m)	15.9		
Momentary Max. peak torque (N·m)	47.7		
Rated current (A(rms))	12.0		
Max. current (A(o-p))	51		
Regenerative brake frequency (times/min) Note1	Without option	357	
	DV0PM20049x2	No limit Note2	
Rated rotational speed (r/min)	3000		
Max. rotational speed (r/min)	4500		
Moment of inertia of rotor (x10 <sup>-4</sup> kg·m <sup>2</sup> )	Without brake	17.4	
	With brake	18.6	
Recommended moment of inertia ratio of the load and the rotor Note3	15 times or less		
Rotary encoder specifications Note5	20-bit Incremental	17-bit Absolute	
	Resolution per single turn	1,048,576	131,072

• **Brake specifications** (For details, refer to P.183)  
 (This brake will be released when it is energized.)  
 (Do not use this for braking the motor in motion.)

Static friction torque (N·m)	16.2 or more
Engaging time (ms)	110 or less
Releasing time (ms) Note4	50 or less
Exciting current (DC) (A)	0.90±10 %
Releasing voltage (DC) (V)	2 or more
Exciting voltage (DC) (V)	24±2.4

• **Permissible load** (For details, refer to P.183)

During assembly	Radial load P-direction (N)	980
	Thrust load A-direction (N)	588
	Thrust load B-direction (N)	686
During operation	Radial load P-direction (N)	784
	Thrust load A, B-direction (N)	343

• For details of Note 1 to Note 5, refer to P.182, 183.  
 • Dimensions of Driver, refer to P.45.

- \*1 Motor specifications: □
- \*2 The product that the end of driver model designation has "E" is "Position control type". Detail of model designation, refer to P.16.
- \*3 ◇ in number of applicable driver represents the series. For more information about the part number, please refer to P.16.

Torque characteristics (at AC400 V of power voltage <Dotted line represents the torque at 10 % less supply voltage.>)

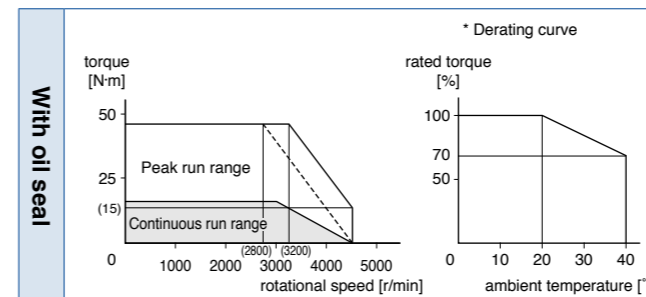

Dimensions

(For IP67 motor, refer to P.138.)

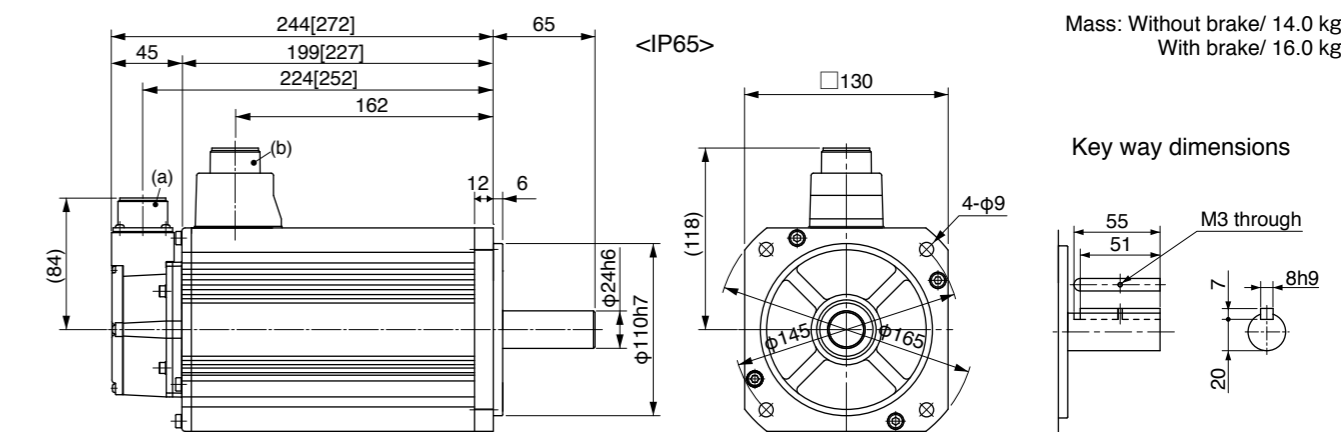

(a) Encoder connector  
 (b) Motor/Brake connector

\* Figures in [ ] represent the dimensions with brake.

[Unit: mm]

<Cautions> Reduce the moment of inertia ratio if high speed response operation is required. Dimensions are subject to change without notice. Contact us or a dealer for the latest information. Read the Instruction Manual carefully and understand all precautions and remarks before using the products.



Specifications

		AC400 V	
Motor model *1	IP65	MDME044GC□	MDME044SC□
	IP67	MDME044G1□	MDME044S1□
Applicable driver *2	Model No. A5II, A5 series	MDD◇T2407	
	A5IE, A5E series	MDD◇T2407E	-
Frame symbol		D-frame	
Power supply capacity (kVA)		0.9	
Rated output (W)		400	
Rated torque (N·m)		1.91	
Momentary Max. peak torque (N·m)		5.73	
Rated current (A(rms))		1.2	
Max. current (A(o-p))		4.9	
Regenerative brake frequency (times/min) Note1	Without option	No limit Note2	
	DV0PM20048	No limit Note2	
Rated rotational speed (r/min)		2000	
Max. rotational speed (r/min)		3000	
Moment of inertia of rotor (×10 <sup>-4</sup> kg·m <sup>2</sup> )	Without brake	1.61	
	With brake	1.9	
Recommended moment of inertia ratio of the load and the rotor Note3		10 times or less	
Rotary encoder specifications Note5	20-bit Incremental		17-bit Absolute
	Resolution per single turn	1,048,576	131,072

• **Brake specifications** (For details, refer to P.183)  
 (This brake will be released when it is energized.)  
 (Do not use this for braking the motor in motion.)

Static friction torque (N·m)	2.5 or more
Engaging time (ms)	50 or less
Releasing time (ms) Note4	15 or less
Exciting current (DC) (A)	0.70±10 %
Releasing voltage (DC) (V)	2 or more
Exciting voltage (DC) (V)	24±2.4

• **Permissible load** (For details, refer to P.183)

During assembly	Radial load P-direction (N)	980
	Thrust load A-direction (N)	588
	Thrust load B-direction (N)	686
During operation	Radial load P-direction (N)	490
	Thrust load A, B-direction (N)	196

• For details of Note 1 to Note 5, refer to P.182, 183.

• Dimensions of Driver, refer to P.44.

\*1 Motor specifications: □

\*2 The product that the end of driver model designation has "E" is "Position control type". Detail of model designation, refer to P.16.

\*3 ◇ in number of applicable driver represents the series. For more information about the part number, please refer to P.16.

Torque characteristics (at AC400 V of power voltage <Dotted line represents the torque at 10 % less supply voltage.>)

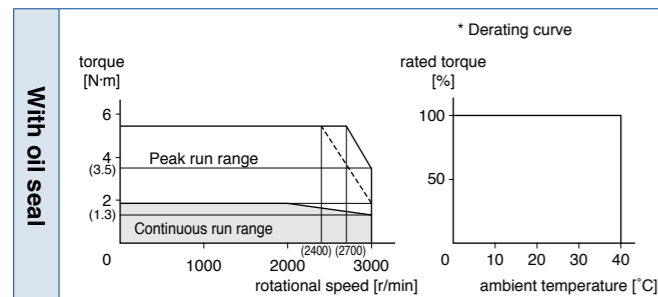

Dimensions

(For IP67 motor, refer to P.138.)

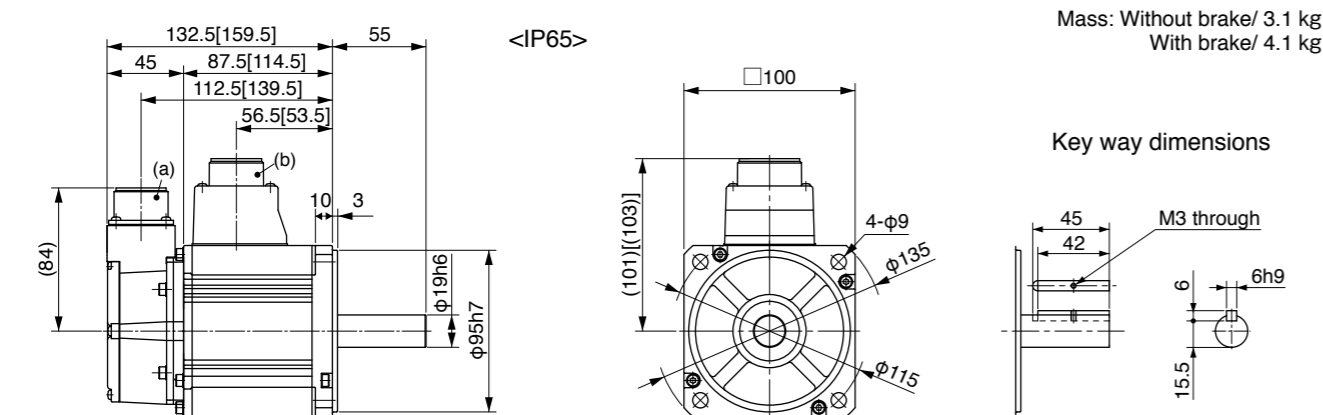

(a) Encoder connector  
 (b) Motor/Brake connector

\* Figures in [ ] represent the dimensions with brake.

[Unit: mm]

<Cautions> Reduce the moment of inertia ratio if high speed response operation is required. Dimensions are subject to change without notice. Contact us or a dealer for the latest information. Read the Instruction Manual carefully and understand all precautions and remarks before using the products.

Specifications

		AC400 V	
Motor model *1	IP65	MDME064GC□	MDME064SC□
	IP67	MDME064G1□	MDME064S1□
Applicable driver *2	Model No. A5II, A5 series	MDD◇T2407	
	A5IE, A5E series	MDD◇T2407E	-
Frame symbol		D-frame	
Power supply capacity (kVA)		1.2	
Rated output (W)		600	
Rated torque (N·m)		2.86	
Momentary Max. peak torque (N·m)		8.59	
Rated current (A(rms))		1.5	
Max. current (A(o-p))		6.5	
Regenerative brake frequency (times/min) Note1	Without option	No limit Note2	
	DV0PM20048	No limit Note2	
Rated rotational speed (r/min)		2000	
Max. rotational speed (r/min)		3000	
Moment of inertia of rotor (×10 <sup>-4</sup> kg·m <sup>2</sup> )	Without brake	2.03	
	With brake	2.35	
Recommended moment of inertia ratio of the load and the rotor Note3		10 times or less	
Rotary encoder specifications Note5	20-bit Incremental		17-bit Absolute
	Resolution per single turn	1,048,576	131,072

• **Brake specifications** (For details, refer to P.183)  
 (This brake will be released when it is energized.)  
 (Do not use this for braking the motor in motion.)

Static friction torque (N·m)	2.5 or more
Engaging time (ms)	50 or less
Releasing time (ms) Note4	15 or less
Exciting current (DC) (A)	0.70±10 %
Releasing voltage (DC) (V)	2 or more
Exciting voltage (DC) (V)	24±2.4

• **Permissible load** (For details, refer to P.183)

During assembly	Radial load P-direction (N)	980
	Thrust load A-direction (N)	588
	Thrust load B-direction (N)	686
During operation	Radial load P-direction (N)	490
	Thrust load A, B-direction (N)	196

• For details of Note 1 to Note 5, refer to P.182, 183.

• Dimensions of Driver, refer to P.44.

\*1 Motor specifications: □

\*2 The product that the end of driver model designation has "E" is "Position control type". Detail of model designation, refer to P.16.

\*3 ◇ in number of applicable driver represents the series. For more information about the part number, please refer to P.16.

Torque characteristics (at AC400 V of power voltage <Dotted line represents the torque at 10 % less supply voltage.>)

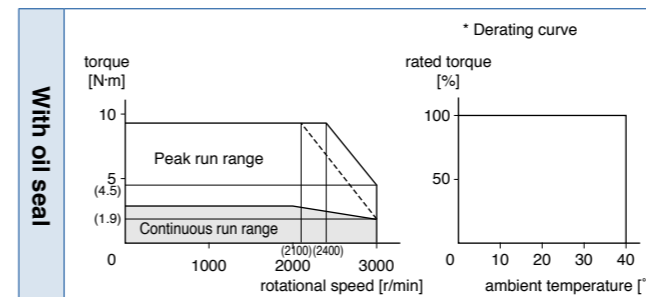

Dimensions

(For IP67 motor, refer to P.138.)

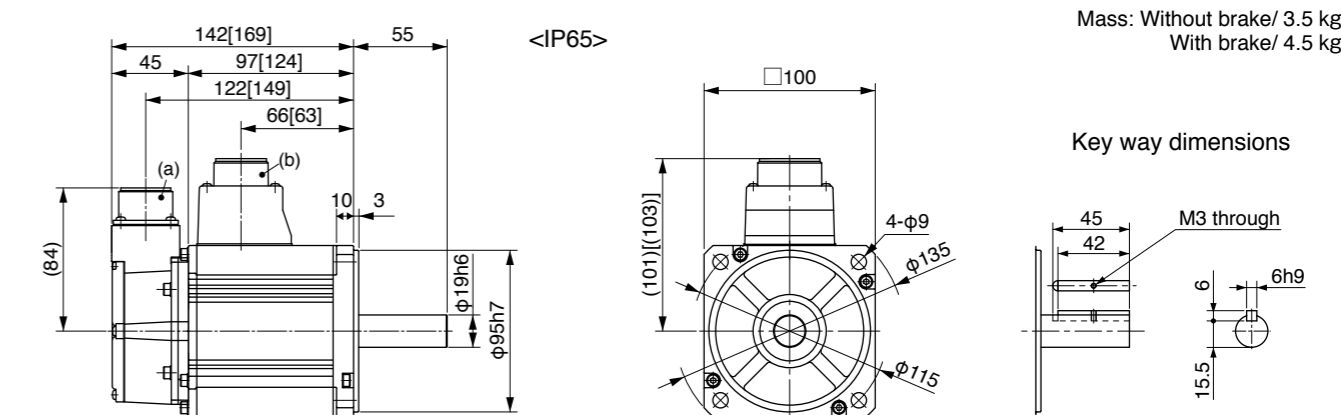

(a) Encoder connector  
 (b) Motor/Brake connector

\* Figures in [ ] represent the dimensions with brake.

[Unit: mm]

<Cautions> Reduce the moment of inertia ratio if high speed response operation is required. Dimensions are subject to change without notice. Contact us or a dealer for the latest information. Read the Instruction Manual carefully and understand all precautions and remarks before using the products.

Specifications

		AC400 V	
Motor model *1	IP65	MDME104GC□	MDME104SC□
	IP67	MDME104G1□	MDME104S1□
Applicable driver *2	Model No. A5II, A5 series	MDD◇T2412	
	A5IE, A5E series	MDD◇T2412E	-
Frame symbol		D-frame	
Power supply capacity (kVA)		1.8	
Rated output (W)		1000	
Rated torque (N·m)		4.77	
Momentary Max. peak torque (N·m)		14.3	
Rated current (A(rms))		2.8	
Max. current (A(o-p))		12	
Regenerative brake frequency (times/min) Note1	Without option	No limit Note2	
	DV0PM20048	No limit Note2	
Rated rotational speed (r/min)		2000	
Max. rotational speed (r/min)		3000	
Moment of inertia of rotor (×10 <sup>-4</sup> kg·m <sup>2</sup> )	Without brake	4.60	
	With brake	5.90	
Recommended moment of inertia ratio of the load and the rotor Note3		10 times or less	
Rotary encoder specifications Note5	20-bit Incremental		17-bit Absolute
	Resolution per single turn	1,048,576	131,072

• **Brake specifications** (For details, refer to P.183)  
 (This brake will be released when it is energized.)  
 (Do not use this for braking the motor in motion.)

Static friction torque (N·m)	4.9 or more
Engaging time (ms)	80 or less
Releasing time (ms) Note4	70 or less
Exciting current (DC) (A)	0.59±10 %
Releasing voltage (DC) (V)	2 or more
Exciting voltage (DC) (V)	24±2.4

• **Permissible load** (For details, refer to P.183)

During assembly	Radial load P-direction (N)	980
	Thrust load A-direction (N)	588
	Thrust load B-direction (N)	686
During operation	Radial load P-direction (N)	490
	Thrust load A, B-direction (N)	196

• For details of Note 1 to Note 5, refer to P.182, 183.  
 • Dimensions of Driver, refer to P.44.

- \*1 Motor specifications: □
- \*2 The product that the end of driver model designation has "E" is "Position control type". Detail of model designation, refer to P.16.
- \*3 ◇ in number of applicable driver represents the series. For more information about the part number, please refer to P.16.

Torque characteristics (at AC400 V of power voltage <Dotted line represents the torque at 10 % less supply voltage.>)

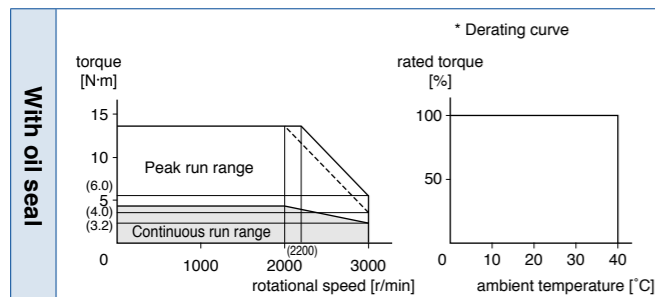

Dimensions

(For IP67 motor, refer to P.138.)

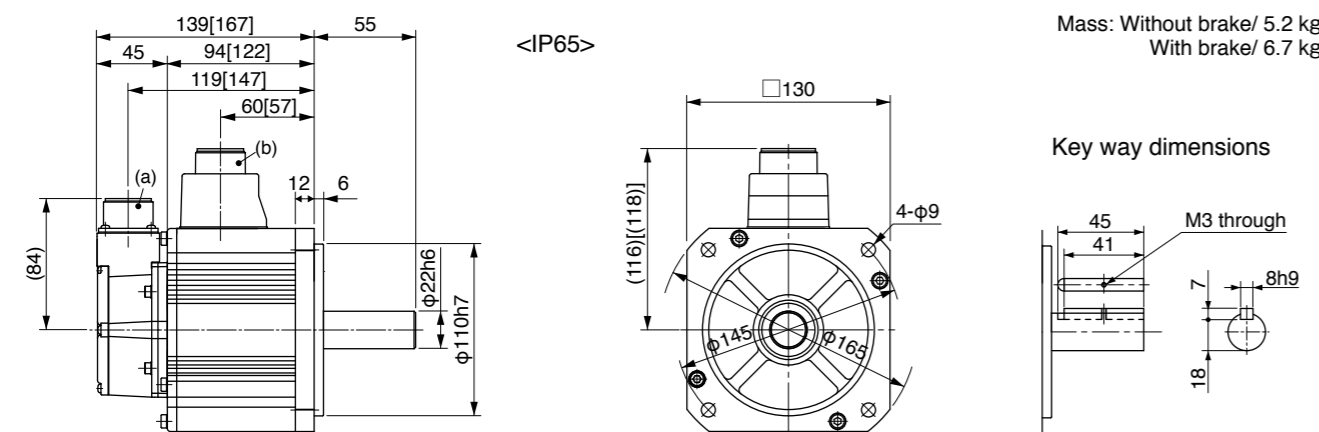

(a) Encoder connector  
 (b) Motor/Brake connector

\* Figures in [ ] represent the dimensions with brake.

[Unit: mm]

<Cautions> Reduce the moment of inertia ratio if high speed response operation is required. Dimensions are subject to change without notice. Contact us or a dealer for the latest information. Read the Instruction Manual carefully and understand all precautions and remarks before using the products.

Specifications

		AC400 V	
Motor model *1	IP65	MDME154GC□	MDME154SC□
	IP67	MDME154G1□	MDME154S1□
Applicable driver *2	Model No. A5II, A5 series	MDD◇T3420	
	A5IE, A5E series	MDD◇T3420E	-
Frame symbol		D-frame	
Power supply capacity (kVA)		2.3	
Rated output (W)		1500	
Rated torque (N·m)		7.16	
Momentary Max. peak torque (N·m)		21.5	
Rated current (A(rms))		4.7	
Max. current (A(o-p))		20	
Regenerative brake frequency (times/min) Note1	Without option	No limit Note2	
	DV0PM20048	No limit Note2	
Rated rotational speed (r/min)		2000	
Max. rotational speed (r/min)		3000	
Moment of inertia of rotor (×10 <sup>-4</sup> kg·m <sup>2</sup> )	Without brake	6.70	
	With brake	7.99	
Recommended moment of inertia ratio of the load and the rotor Note3		10 times or less	
Rotary encoder specifications Note5	20-bit Incremental		17-bit Absolute
	Resolution per single turn	1,048,576	131,072

• **Brake specifications** (For details, refer to P.183)  
 (This brake will be released when it is energized.)  
 (Do not use this for braking the motor in motion.)

Static friction torque (N·m)	13.7 or more
Engaging time (ms)	100 or less
Releasing time (ms) Note4	50 or less
Exciting current (DC) (A)	0.79±10 %
Releasing voltage (DC) (V)	2 or more
Exciting voltage (DC) (V)	24±2.4

• **Permissible load** (For details, refer to P.183)

During assembly	Radial load P-direction (N)	980
	Thrust load A-direction (N)	588
	Thrust load B-direction (N)	686
During operation	Radial load P-direction (N)	490
	Thrust load A, B-direction (N)	196

• For details of Note 1 to Note 5, refer to P.182, 183.  
 • Dimensions of Driver, refer to P.44.

- \*1 Motor specifications: □
- \*2 The product that the end of driver model designation has "E" is "Position control type". Detail of model designation, refer to P.16.
- \*3 ◇ in number of applicable driver represents the series. For more information about the part number, please refer to P.16.

Torque characteristics (at AC400 V of power voltage <Dotted line represents the torque at 10 % less supply voltage.>)

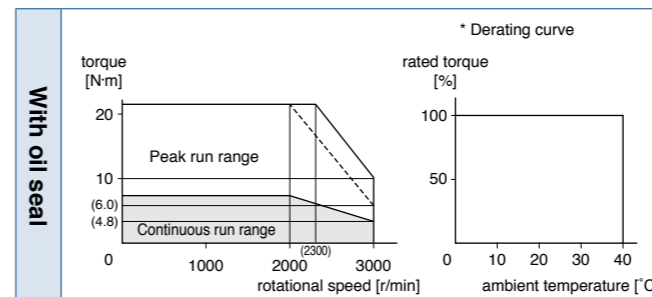

Dimensions

(For IP67 motor, refer to P.138.)

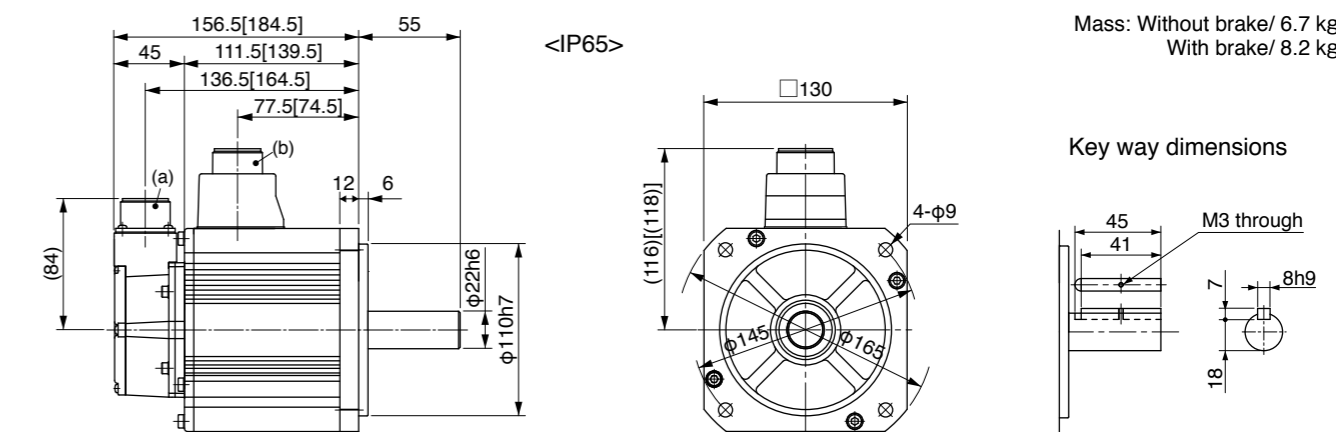

(a) Encoder connector  
 (b) Motor/Brake connector

\* Figures in [ ] represent the dimensions with brake.

[Unit: mm]

<Cautions> Reduce the moment of inertia ratio if high speed response operation is required. Dimensions are subject to change without notice. Contact us or a dealer for the latest information. Read the Instruction Manual carefully and understand all precautions and remarks before using the products.

Specifications

		AC400 V	
Motor model *1	IP65	MDME204GC□	MDME204SC□
	IP67	MDME204G1□	MDME204S1□
Applicable driver *2	Model No. A5II, A5 series	MED◇T4430	
	A5IE, A5E series	MED◇T4430E	-
Frame symbol		E-frame	
Power supply capacity (kVA)		3.3	
Rated output (W)		2000	
Rated torque (N·m)		9.55	
Momentary Max. peak torque (N·m)		28.6	
Rated current (A(rms))		5.9	
Max. current (A(o-p))		25	
Regenerative brake frequency (times/min) Note1	Without option	No limit Note2	
	DV0PM20049	No limit Note2	
Rated rotational speed (r/min)		2000	
Max. rotational speed (r/min)		3000	
Moment of inertia of rotor (×10 <sup>-4</sup> kg·m <sup>2</sup> )	Without brake	8.72	
	With brake	10.0	
Recommended moment of inertia ratio of the load and the rotor Note3		10 times or less	
Rotary encoder specifications Note5	20-bit Incremental		17-bit Absolute
	Resolution per single turn	1,048,576	131,072

• **Brake specifications** (For details, refer to P.183)  
 (This brake will be released when it is energized.)  
 (Do not use this for braking the motor in motion.)

Static friction torque (N·m)	13.7 or more
Engaging time (ms)	100 or less
Releasing time (ms) Note4	50 or less
Exciting current (DC) (A)	0.79±10 %
Releasing voltage (DC) (V)	2 or more
Exciting voltage (DC) (V)	24±2.4

• **Permissible load** (For details, refer to P.183)

During assembly	Radial load P-direction (N)	980
	Thrust load A-direction (N)	588
	Thrust load B-direction (N)	686
During operation	Radial load P-direction (N)	490
	Thrust load A, B-direction (N)	196

• For details of Note 1 to Note 5, refer to P.182, 183.

• Dimensions of Driver, refer to P.45.

\*1 Motor specifications: □

\*2 The product that the end of driver model designation has "E" is "Position control type". Detail of model designation, refer to P.16.

\*3 ◇ in number of applicable driver represents the series. For more information about the part number, please refer to P.16.

Torque characteristics (at AC400 V of power voltage <Dotted line represents the torque at 10 % less supply voltage.>)

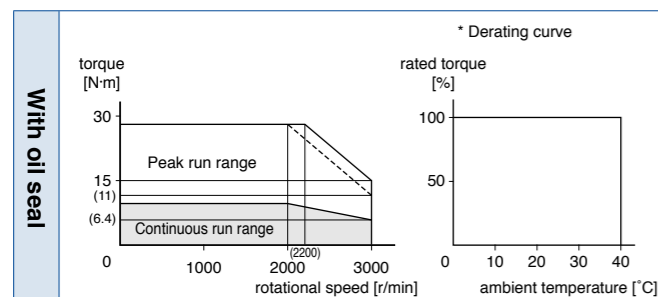

Dimensions

(For IP67 motor, refer to P.138.)

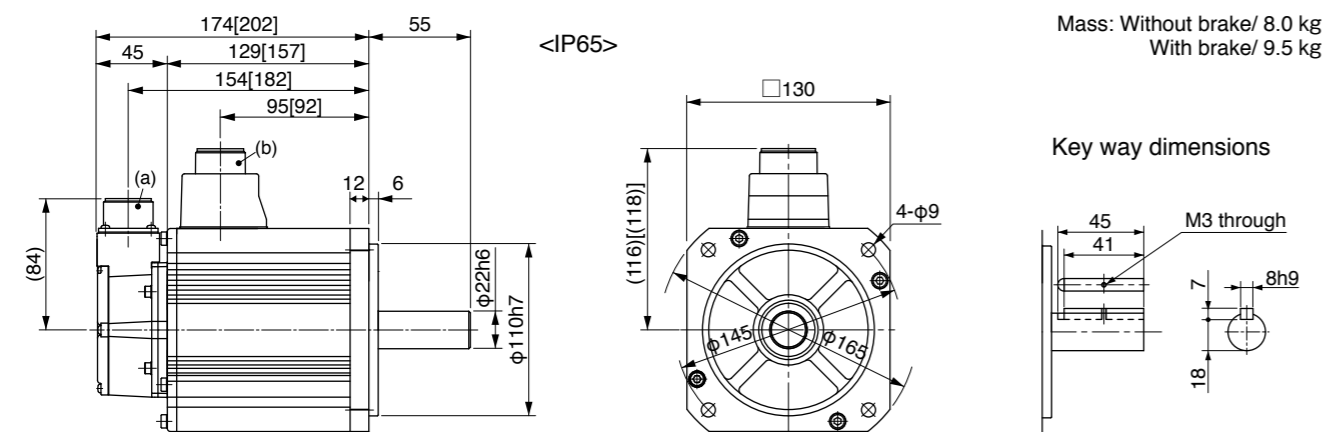

(a) Encoder connector  
 (b) Motor/Brake connector

\* Figures in [ ] represent the dimensions with brake.

[Unit: mm]

<Cautions> Reduce the moment of inertia ratio if high speed response operation is required. Dimensions are subject to change without notice. Contact us or a dealer for the latest information. Read the Instruction Manual carefully and understand all precautions and remarks before using the products.

Specifications

		AC400 V	
Motor model *1	IP65	MDME304GC□	MDME304SC□
	IP67	MDME304G1□	MDME304S1□
Applicable driver *2	Model No. A5II, A5 series	MFD◇T5440	
	A5IE, A5E series	MFD◇T5440E	-
Frame symbol		F-frame	
Power supply capacity (kVA)		4.5	
Rated output (W)		3000	
Rated torque (N·m)		14.3	
Momentary Max. peak torque (N·m)		43.0	
Rated current (A(rms))		8.7	
Max. current (A(o-p))		37	
Regenerative brake frequency (times/min) Note1	Without option	No limit Note2	
	DV0PM20049x2	No limit Note2	
Rated rotational speed (r/min)		2000	
Max. rotational speed (r/min)		3000	
Moment of inertia of rotor (×10 <sup>-4</sup> kg·m <sup>2</sup> )	Without brake	12.9	
	With brake	14.2	
Recommended moment of inertia ratio of the load and the rotor Note3		10 times or less	
Rotary encoder specifications Note5	20-bit Incremental		17-bit Absolute
	Resolution per single turn	1,048,576	131,072

• **Brake specifications** (For details, refer to P.183)  
 (This brake will be released when it is energized.)  
 (Do not use this for braking the motor in motion.)

Static friction torque (N·m)	16.2 or more
Engaging time (ms)	110 or less
Releasing time (ms) Note4	50 or less
Exciting current (DC) (A)	0.90±10 %
Releasing voltage (DC) (V)	2 or more
Exciting voltage (DC) (V)	24±2.4

• **Permissible load** (For details, refer to P.183)

During assembly	Radial load P-direction (N)	980
	Thrust load A-direction (N)	588
	Thrust load B-direction (N)	686
During operation	Radial load P-direction (N)	784
	Thrust load A, B-direction (N)	343

• For details of Note 1 to Note 5, refer to P.182, 183.

• Dimensions of Driver, refer to P.45.

\*1 Motor specifications: □

\*2 The product that the end of driver model designation has "E" is "Position control type". Detail of model designation, refer to P.16.

\*3 ◇ in number of applicable driver represents the series. For more information about the part number, please refer to P.16.

Torque characteristics (at AC400 V of power voltage <Dotted line represents the torque at 10 % less supply voltage.>)

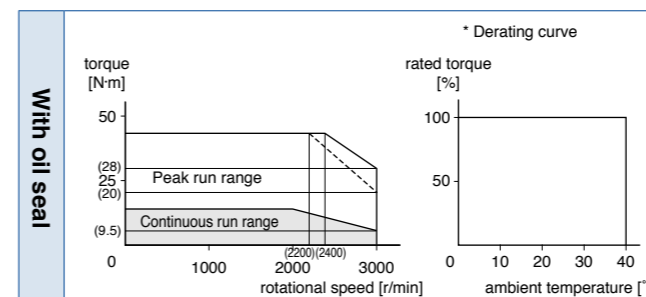

Dimensions

(For IP67 motor, refer to P.139.)

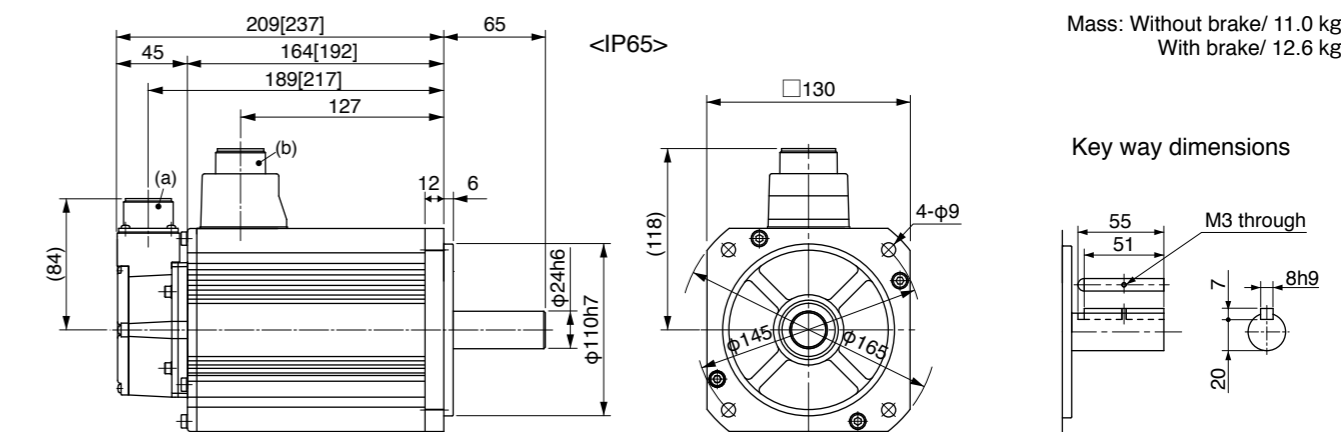

(a) Encoder connector  
 (b) Motor/Brake connector

\* Figures in [ ] represent the dimensions with brake.

[Unit: mm]

<Cautions> Reduce the moment of inertia ratio if high speed response operation is required. Dimensions are subject to change without notice. Contact us or a dealer for the latest information. Read the Instruction Manual carefully and understand all precautions and remarks before using the products.

Specifications

		AC400 V	
Motor model *1	IP65	MDME404GC□	MDME404SC□
	IP67	MDME404G1□	MDME404S1□
Applicable driver *2	Model No.	A5II, A5 series	MFD◇TA464
		A5IE, A5E series	MFD◇TA464E
	Frame symbol	F-frame	
Power supply capacity (kVA)	6.8		
Rated output (W)	4000		
Rated torque (N·m)	19.1		
Momentary Max. peak torque (N·m)	57.3		
Rated current (A(rms))	10.6		
Max. current (A(o-p))	45		
Regenerative brake frequency (times/min) Note1	Without option	No limit Note2	
	DV0PM20049x2	No limit Note2	
Rated rotational speed (r/min)	2000		
Max. rotational speed (r/min)	3000		
Moment of inertia of rotor (x10 <sup>-4</sup> kg·m <sup>2</sup> )	Without brake	37.6	
	With brake	38.6	
Recommended moment of inertia ratio of the load and the rotor Note3	10 times or less		
Rotary encoder specifications Note5	20-bit Incremental	17-bit Absolute	
	Resolution per single turn	1,048,576	131,072

• **Brake specifications** (For details, refer to P.183)  
 (This brake will be released when it is energized.)  
 (Do not use this for braking the motor in motion.)

Static friction torque (N·m)	24.5 or more
Engaging time (ms)	80 or less
Releasing time (ms) Note4	25 or less
Exciting current (DC) (A)	1.3±10 %
Releasing voltage (DC) (V)	2 or more
Exciting voltage (DC) (V)	24±2.4

• **Permissible load** (For details, refer to P.183)

During assembly	Radial load P-direction (N)	1666
	Thrust load A-direction (N)	784
	Thrust load B-direction (N)	980
During operation	Radial load P-direction (N)	784
	Thrust load A, B-direction (N)	343

• For details of Note 1 to Note 5, refer to P.182, 183.

• Dimensions of Driver, refer to P.45.

\*1 Motor specifications: □

\*2 The product that the end of driver model designation has "E" is "Position control type". Detail of model designation, refer to P.16.

\*3 ◇ in number of applicable driver represents the series. For more information about the part number, please refer to P.16.

Torque characteristics (at AC400 V of power voltage <Dotted line represents the torque at 10 % less supply voltage.>)

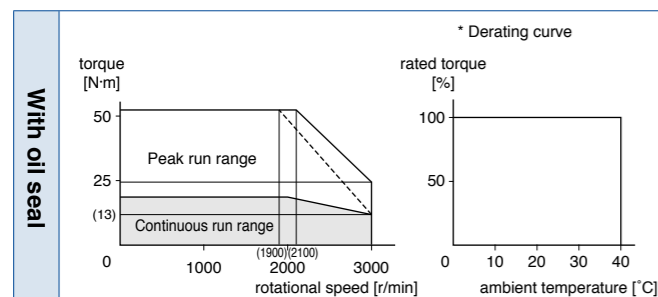

Dimensions

(For IP67 motor, refer to P.139.)

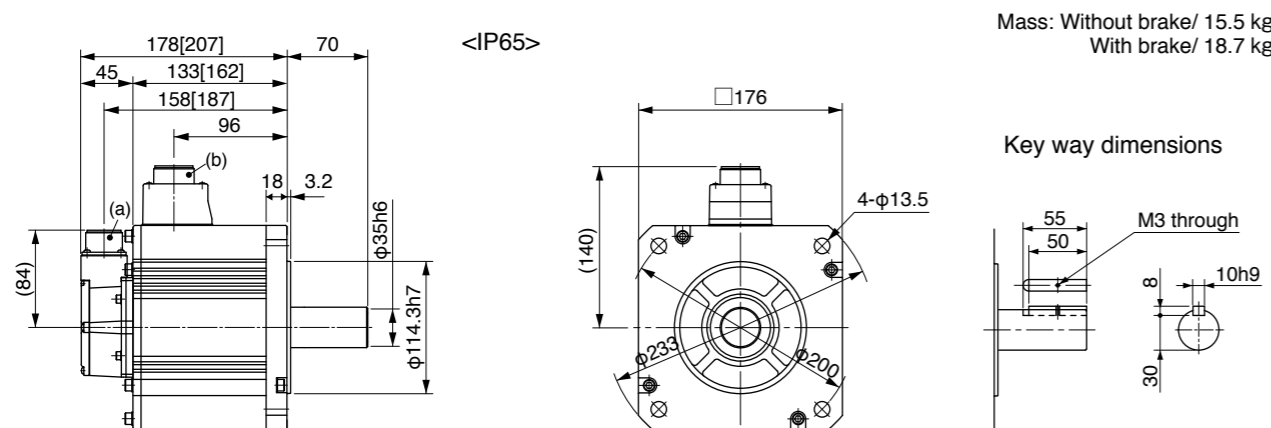

(a) Encoder connector  
 (b) Motor/Brake connector

\* Figures in [ ] represent the dimensions with brake.

[Unit: mm]

<Cautions> Reduce the moment of inertia ratio if high speed response operation is required. Dimensions are subject to change without notice. Contact us or a dealer for the latest information. Read the Instruction Manual carefully and understand all precautions and remarks before using the products.

Specifications

		AC400 V	
Motor model *1	IP65	MDME504GC□	MDME504SC□
	IP67	MDME504G1□	MDME504S1□
Applicable driver *2	Model No.	A5II, A5 series	MFD◇TA464
		A5IE, A5E series	MFD◇TA464E
	Frame symbol	F-frame	
Power supply capacity (kVA)	7.5		
Rated output (W)	5000		
Rated torque (N·m)	23.9		
Momentary Max. peak torque (N·m)	71.6		
Rated current (A(rms))	13.0		
Max. current (A(o-p))	55		
Regenerative brake frequency (times/min) Note1	Without option	120	
	DV0PM20049x2	No limit Note2	
Rated rotational speed (r/min)	2000		
Max. rotational speed (r/min)	3000		
Moment of inertia of rotor (x10 <sup>-4</sup> kg·m <sup>2</sup> )	Without brake	48.0	
	With brake	48.8	
Recommended moment of inertia ratio of the load and the rotor Note3	10 times or less		
Rotary encoder specifications Note5	20-bit Incremental	17-bit Absolute	
	Resolution per single turn	1,048,576	131,072

• **Brake specifications** (For details, refer to P.183)  
 (This brake will be released when it is energized.)  
 (Do not use this for braking the motor in motion.)

Static friction torque (N·m)	24.5 or more
Engaging time (ms)	80 or less
Releasing time (ms) Note4	25 or less
Exciting current (DC) (A)	1.3±10 %
Releasing voltage (DC) (V)	2 or more
Exciting voltage (DC) (V)	24±2.4

• **Permissible load** (For details, refer to P.183)

During assembly	Radial load P-direction (N)	1666
	Thrust load A-direction (N)	784
	Thrust load B-direction (N)	980
During operation	Radial load P-direction (N)	784
	Thrust load A, B-direction (N)	343

• For details of Note 1 to Note 5, refer to P.182, 183.

• Dimensions of Driver, refer to P.45.

\*1 Motor specifications: □

\*2 The product that the end of driver model designation has "E" is "Position control type". Detail of model designation, refer to P.16.

\*3 ◇ in number of applicable driver represents the series. For more information about the part number, please refer to P.16.

Torque characteristics (at AC400 V of power voltage <Dotted line represents the torque at 10 % less supply voltage.>)

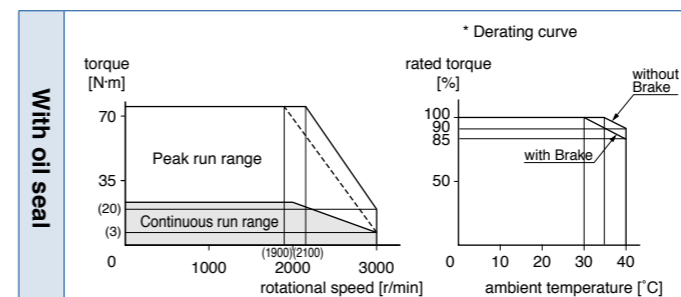

Dimensions

(For IP67 motor, refer to P.139.)

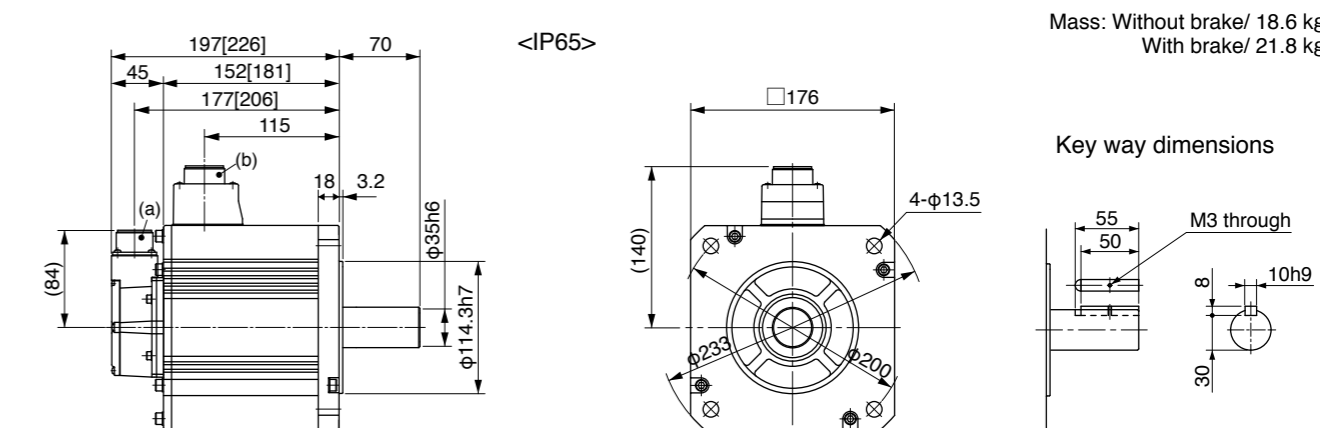

(a) Encoder connector  
 (b) Motor/Brake connector

\* Figures in [ ] represent the dimensions with brake.

[Unit: mm]

<Cautions> Reduce the moment of inertia ratio if high speed response operation is required. Dimensions are subject to change without notice. Contact us or a dealer for the latest information. Read the Instruction Manual carefully and understand all precautions and remarks before using the products.

Specifications

		AC400 V	
Motor model *1	IP65	-	-
	IP67	MDME754G1□	MDME754S1□
Applicable driver *2	Model No. A5II, A5 series	MGD◇TB4A2	
	A5IE, A5E series	-	-
Frame symbol		G-frame	
Power supply capacity (kVA)	11		
Rated output (W)	7500		
Rated torque (N·m)	47.8		
Momentary Max. peak torque (N·m)	119		
Rated current (A(rms))	22		
Max. current (A(o-p))	83		
Regenerative brake frequency (times/min) Note1	Without option	No limit Note2	
	DV0PM20049x3	No limit Note2	
Rated rotational speed (r/min)	1500		
Max. rotational speed (r/min)	3000		
Moment of inertia of rotor (x10 <sup>-4</sup> kg·m <sup>2</sup> )	Without brake	101	
	With brake	107	
Recommended moment of inertia ratio of the load and the rotor Note3	10 times or less		
Rotary encoder specifications Note5	20-bit Incremental	17-bit Absolute	
	Resolution per single turn	1,048,576	131,072

• **Brake specifications** (For details, refer to P.183)  
 (This brake will be released when it is energized.)  
 (Do not use this for braking the motor in motion.)

Static friction torque (N·m)	58.8 or more
Engaging time (ms)	150 or less
Releasing time (ms) Note4	50 or less
Exciting current (DC) (A)	1.4±10 %
Releasing voltage (DC) (V)	2 or more
Exciting voltage (DC) (V)	24±2.4

• **Permissible load** (For details, refer to P.183)

During assembly	Radial load P-direction (N)	2058
	Thrust load A-direction (N)	980
	Thrust load B-direction (N)	1176
During operation	Radial load P-direction (N)	1176
	Thrust load A, B-direction (N)	490

• For details of Note 1 to Note 5, refer to P.182, 183.

• Dimensions of Driver, refer to P.46.

\*1 Motor specifications: □

\*2 The product that the end of driver model designation has "E" is "Position control type". Detail of model designation, refer to P.16.

\*3 ◇ in number of applicable driver represents the series. For more information about the part number, please refer to P.16.

Torque characteristics (at AC200 V of power voltage <Dotted line represents the torque at 10 % less supply voltage.>)

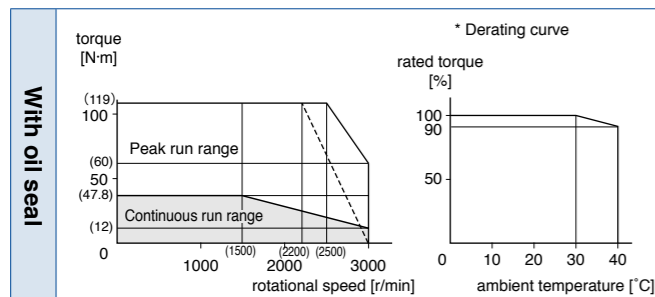

Dimensions

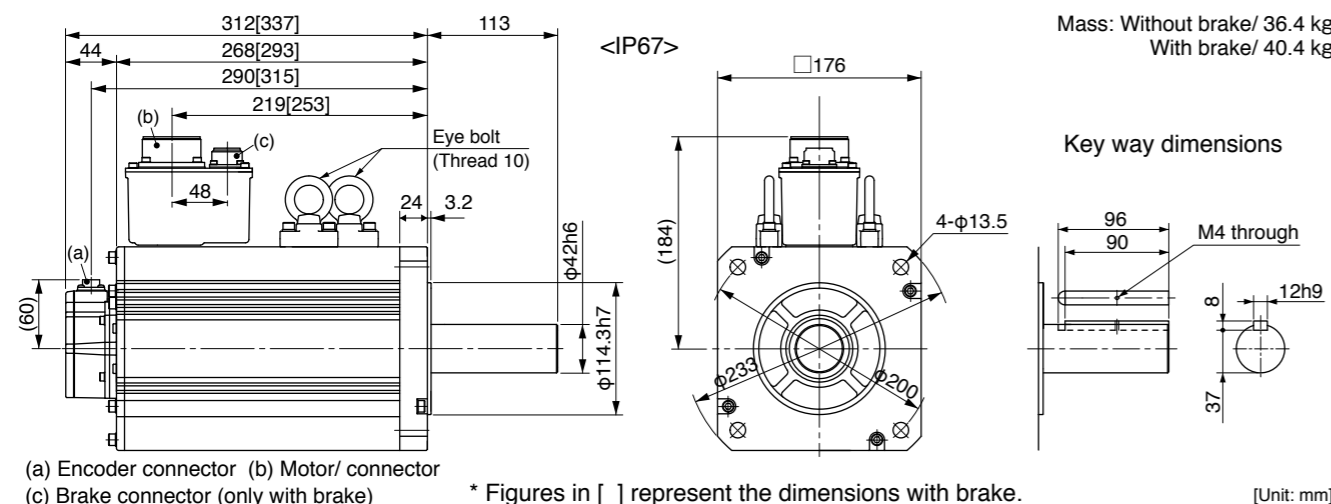

<Cautions> Reduce the moment of inertia ratio if high speed response operation is required. Dimensions are subject to change without notice. Contact us or a dealer for the latest information. Read the Instruction Manual carefully and understand all precautions and remarks before using the products.

Specifications

		AC400 V	
Motor model *1	IP65	-	-
	IP67	MDMEC14G1□	MDMEC14S1□
Applicable driver *2	Model No. A5II, A5 series	MHD◇TB4A2	
	A5IE, A5E series	-	-
Frame symbol		H-frame	
Power supply capacity (kVA)	17		
Rated output (W)	11000		
Rated torque (N·m)	70		
Momentary Max. peak torque (N·m)	175		
Rated current (A(rms))	27.1		
Max. current (A(o-p))	101		
Regenerative brake frequency (times/min) Note1	Without option	No limit Note2	
	DV0PM20059	No limit Note2	
Rated rotational speed (r/min)	1500		
Max. rotational speed (r/min)	2000		
Moment of inertia of rotor (x10 <sup>-4</sup> kg·m <sup>2</sup> )	Without brake	212	
	With brake	220	
Recommended moment of inertia ratio of the load and the rotor Note3	10 times or less		
Rotary encoder specifications Note5	20-bit Incremental	17-bit Absolute	
	Resolution per single turn	1,048,576	131,072

• **Brake specifications** (For details, refer to P.183)  
 (This brake will be released when it is energized.)  
 (Do not use this for braking the motor in motion.)

Static friction torque (N·m)	100 or more
Engaging time (ms)	300 or less
Releasing time (ms) Note4	140 or less
Exciting current (DC) (A)	1.08±10 %
Releasing voltage (DC) (V)	2 or more
Exciting voltage (DC) (V)	24±2.4

• **Permissible load** (For details, refer to P.183)

During assembly	Radial load P-direction (N)	4508
	Thrust load A-direction (N)	1470
	Thrust load B-direction (N)	1764
During operation	Radial load P-direction (N)	2254
	Thrust load A, B-direction (N)	686

• For details of Note 1 to Note 5, refer to P.182, 183.

• Dimensions of Driver, refer to P.46.

\*1 Motor specifications: □

\*2 The product that the end of driver model designation has "E" is "Position control type". Detail of model designation, refer to P.16.

\*3 ◇ in number of applicable driver represents the series. For more information about the part number, please refer to P.16.

Torque characteristics (at AC200 V of power voltage <Dotted line represents the torque at 10 % less supply voltage.>)

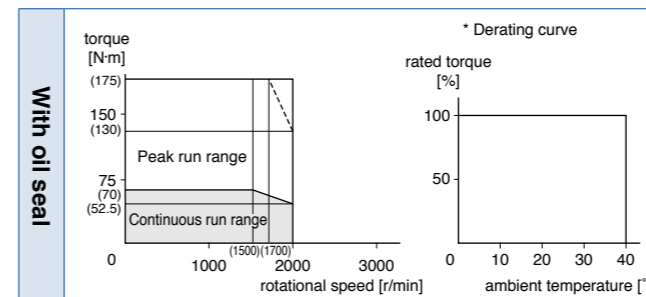

Dimensions

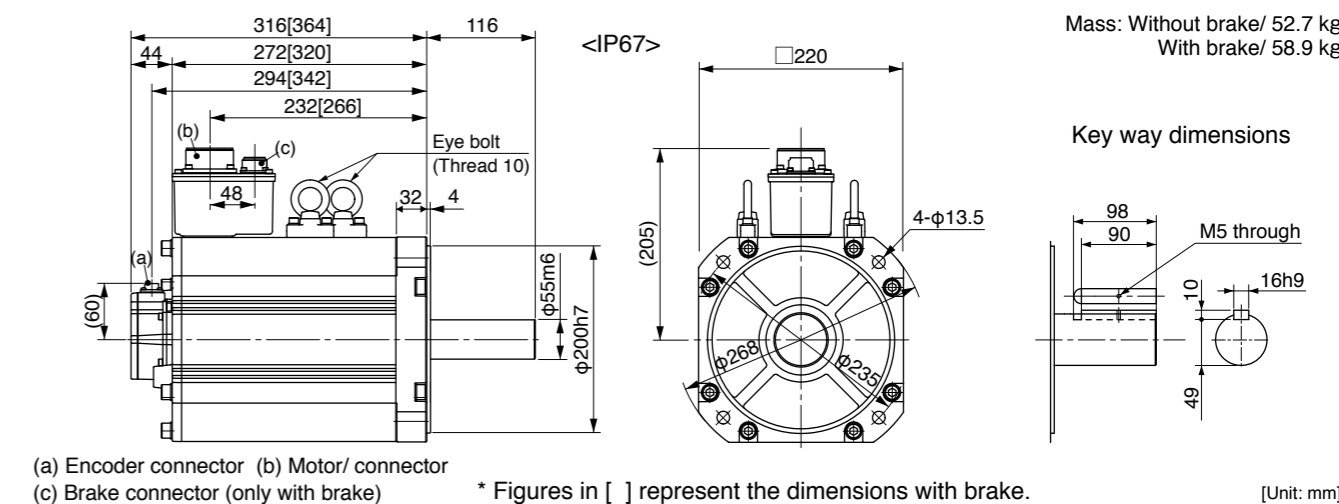

<Cautions> Reduce the moment of inertia ratio if high speed response operation is required. Dimensions are subject to change without notice. Contact us or a dealer for the latest information. Read the Instruction Manual carefully and understand all precautions and remarks before using the products.

Specifications

		AC400 V	
Motor model *1	IP65	-	-
	IP67	MDMEC54G1□	MDMEC54S1□
Applicable driver *2	Model No. A5II, A5 series	MHD◇TB4A2	
	A5IE, A5E series	-	-
Frame symbol		H-frame	
Power supply capacity (kVA)	22		
Rated output (W)	15000		
Rated torque (N·m)	95.5		
Momentary Max. peak torque (N·m)	224		
Rated current (A(rms))	33.1		
Max. current (A(o-p))	118		
Regenerative brake frequency (times/min) Note1	Without option	No limit Note2	
	DV0PM20059	No limit Note2	
Rated rotational speed (r/min)	1500		
Max. rotational speed (r/min)	2000		
Moment of inertia of rotor (x10 <sup>-4</sup> kg·m <sup>2</sup> )	Without brake	302	
	With brake	211	
Recommended moment of inertia ratio of the load and the rotor Note3	10 times or less		
Rotary encoder specifications Note5	20-bit Incremental	17-bit Absolute	
	Resolution per single turn	1,048,576	131,072

• **Brake specifications** (For details, refer to P.183)  
 (This brake will be released when it is energized.)  
 (Do not use this for braking the motor in motion.)

Static friction torque (N·m)	100 or more
Engaging time (ms)	300 or less
Releasing time (ms) Note4	140 or less
Exciting current (DC) (A)	1.08±10 %
Releasing voltage (DC) (V)	2 or more
Exciting voltage (DC) (V)	24±2.4

• **Permissible load** (For details, refer to P.183)

During assembly	Radial load P-direction (N)	4508
	Thrust load A-direction (N)	1470
	Thrust load B-direction (N)	1764
During operation	Radial load P-direction (N)	2254
	Thrust load A, B-direction (N)	686

• For details of Note 1 to Note 5, refer to P.182, 183.  
 • Dimensions of Driver, refer to P.47.

- \*1 Motor specifications: □
- \*2 The product that the end of driver model designation has "E" is "Position control type". Detail of model designation, refer to P.16.
- \*3 ◇ in number of applicable driver represents the series. For more information about the part number, please refer to P.16.

Torque characteristics (at AC200 V of power voltage <Dotted line represents the torque at 10 % less supply voltage.>)

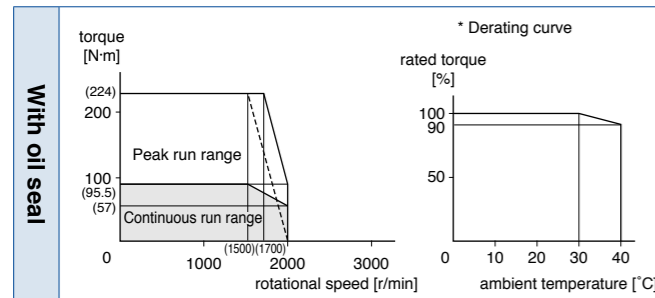

Dimensions

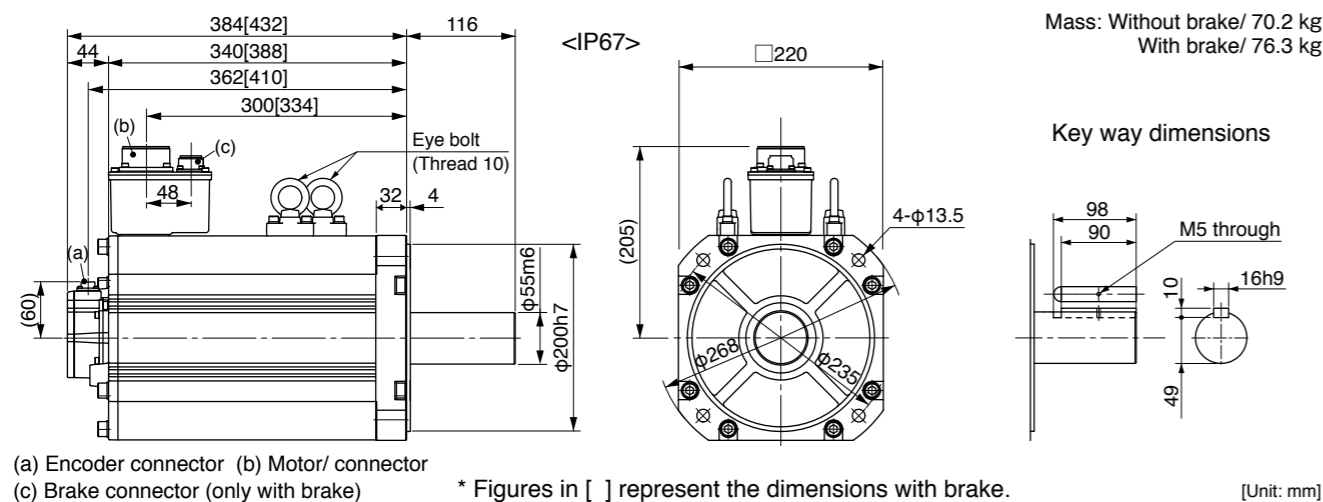

(a) Encoder connector (b) Motor/ connector (c) Brake connector (only with brake) \* Figures in [ ] represent the dimensions with brake.  
**<Cautions>** Reduce the moment of inertia ratio if high speed response operation is required. Dimensions are subject to change without notice. Contact us or a dealer for the latest information. Read the Instruction Manual carefully and understand all precautions and remarks before using the products.

Specifications

		AC400 V	
Motor model *1	IP65	-	-
	IP67	MFME154G1□	MFME154S1□
Applicable driver *2	Model No. A5II, A5 series	MDD◇T3420	
	A5IE, A5E series	MDD◇T3420E	-
Frame symbol		D-frame	
Power supply capacity (kVA)	2.4		
Rated output (W)	1500		
Rated torque (N·m)	7.16		
Momentary Max. peak torque (N·m)	21.5		
Rated current (A(rms))	3.8		
Max. current (A(o-p))	16		
Regenerative brake frequency (times/min) Note1	Without option	100	
	DV0PM20048	No limit Note2	
Rated rotational speed (r/min)	2000		
Max. rotational speed (r/min)	3000		
Moment of inertia of rotor (x10 <sup>-4</sup> kg·m <sup>2</sup> )	Without brake	18.2	
	With brake	23.5	
Recommended moment of inertia ratio of the load and the rotor Note3	10 times or less		
Rotary encoder specifications Note5	20-bit Incremental	17-bit Absolute	
	Resolution per single turn	1,048,576	131,072

• **Brake specifications** (For details, refer to P.183)  
 (This brake will be released when it is energized.)  
 (Do not use this for braking the motor in motion.)

Static friction torque (N·m)	7.8 or more
Engaging time (ms)	80 or less
Releasing time (ms) Note4	35 or less
Exciting current (DC) (A)	0.83±10 %
Releasing voltage (DC) (V)	2 or more
Exciting voltage (DC) (V)	24±2.4

• **Permissible load** (For details, refer to P.183)

During assembly	Radial load P-direction (N)	980
	Thrust load A-direction (N)	588
	Thrust load B-direction (N)	686
During operation	Radial load P-direction (N)	490
	Thrust load A, B-direction (N)	196

• For details of Note 1 to Note 5, refer to P.182, 183.  
 • Dimensions of Driver, refer to P.44.

- \*1 Motor specifications: □
- \*2 The product that the end of driver model designation has "E" is "Position control type". Detail of model designation, refer to P.16.
- \*3 ◇ in number of applicable driver represents the series. For more information about the part number, please refer to P.16.

Torque characteristics (at AC200 V of power voltage <Dotted line represents the torque at 10 % less supply voltage.>)

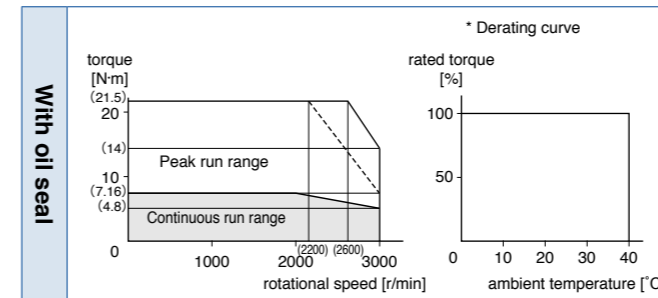

Dimensions

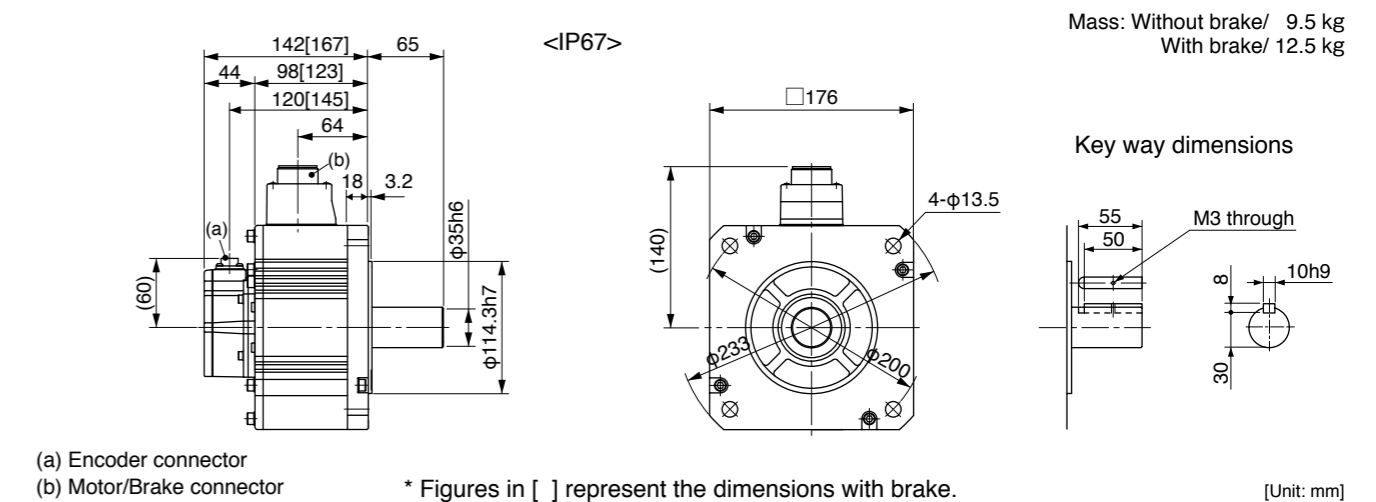

(a) Encoder connector (b) Motor/Brake connector \* Figures in [ ] represent the dimensions with brake.  
**<Cautions>** Reduce the moment of inertia ratio if high speed response operation is required. Dimensions are subject to change without notice. Contact us or a dealer for the latest information. Read the Instruction Manual carefully and understand all precautions and remarks before using the products.

Specifications

		AC400 V	
Motor model *1	IP65	-	-
	IP67	MFME254G1□	MFME254S1□
Applicable driver *2	Model No. A5II, A5 series	MED◇T4430	
	A5IE, A5E series	MED◇T4430E	-
Frame symbol		E-frame	
Power supply capacity (kVA)	3.9		
Rated output (W)	2500		
Rated torque (N·m)	11.9		
Momentary Max. peak torque (N·m)	30.4		
Rated current (A(rms))	6.7		
Max. current (A(o-p))	29		
Regenerative brake frequency (times/min) Note1	Without option	75	
	DV0PM20049	No limit Note2	
Rated rotational speed (r/min)	2000		
Max. rotational speed (r/min)	3000		
Moment of inertia of rotor (×10 <sup>-4</sup> kg·m <sup>2</sup> )	Without brake	35.8	
	With brake	45.2	
Recommended moment of inertia ratio of the load and the rotor Note3	10 times or less		
Rotary encoder specifications Note5	20-bit Incremental	17-bit Absolute	
	Resolution per single turn	1,048,576	131,072

• **Brake specifications** (For details, refer to P.183)  
 (This brake will be released when it is energized.)  
 (Do not use this for braking the motor in motion.)

Static friction torque (N·m)	21.6 or more
Engaging time (ms)	150 or less
Releasing time (ms) Note4	100 or less
Exciting current (DC) (A)	0.75±10 %
Releasing voltage (DC) (V)	2 or more
Exciting voltage (DC) (V)	24±2.4

• **Permissible load** (For details, refer to P.183)

During assembly	Radial load P-direction (N)	1862
	Thrust load A-direction (N)	686
	Thrust load B-direction (N)	686
During operation	Radial load P-direction (N)	784
	Thrust load A, B-direction (N)	294

• For details of Note 1 to Note 5, refer to P.182, 183.  
 • Dimensions of Driver, refer to P.45.

- \*1 Motor specifications: □
- \*2 The product that the end of driver model designation has "E" is "Position control type". Detail of model designation, refer to P.16.
- \*3 ◇ in number of applicable driver represents the series. For more information about the part number, please refer to P.16.

Torque characteristics (at AC200 V of power voltage <Dotted line represents the torque at 10 % less supply voltage.>)

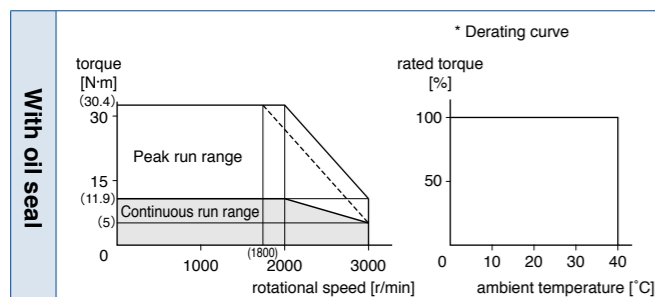

Dimensions

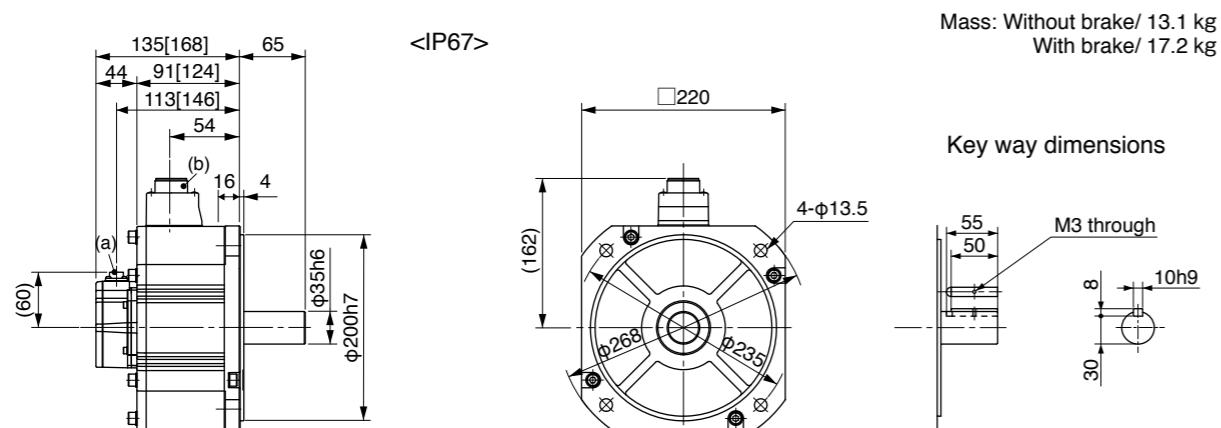

(a) Encoder connector (b) Motor/Brake connector \* Figures in [ ] represent the dimensions with brake. [Unit: mm]

<Cautions> Reduce the moment of inertia ratio if high speed response operation is required. Dimensions are subject to change without notice. Contact us or a dealer for the latest information. Read the Instruction Manual carefully and understand all precautions and remarks before using the products.

Specifications

		AC400 V	
Motor model *1	IP65	-	-
	IP67	MFME454G1□	MFME454S1□
Applicable driver *2	Model No. A5II, A5 series	MFD◇TA464	
	A5IE, A5E series	MFD◇TA464E	-
Frame symbol		F-frame	
Power supply capacity (kVA)	6.9		
Rated output (W)	4500		
Rated torque (N·m)	21.5		
Momentary Max. peak torque (N·m)	54.9		
Rated current (A(rms))	12.4		
Max. current (A(o-p))	53		
Regenerative brake frequency (times/min) Note1	Without option	67	
	DV0PM20049x2	375	
Rated rotational speed (r/min)	2000		
Max. rotational speed (r/min)	3000		
Moment of inertia of rotor (×10 <sup>-4</sup> kg·m <sup>2</sup> )	Without brake	63.1	
	With brake	70.9	
Recommended moment of inertia ratio of the load and the rotor Note3	10 times or less		
Rotary encoder specifications Note5	20-bit Incremental	17-bit Absolute	
	Resolution per single turn	1,048,576	131,072

• **Brake specifications** (For details, refer to P.183)  
 (This brake will be released when it is energized.)  
 (Do not use this for braking the motor in motion.)

Static friction torque (N·m)	31.4 or more
Engaging time (ms)	150 or less
Releasing time (ms) Note4	100 or less
Exciting current (DC) (A)	0.75±10 %
Releasing voltage (DC) (V)	2 or more
Exciting voltage (DC) (V)	24±2.4

• **Permissible load** (For details, refer to P.183)

During assembly	Radial load P-direction (N)	1862
	Thrust load A-direction (N)	686
	Thrust load B-direction (N)	686
During operation	Radial load P-direction (N)	784
	Thrust load A, B-direction (N)	294

• For details of Note 1 to Note 5, refer to P.182, 183.  
 • Dimensions of Driver, refer to P.45.

- \*1 Motor specifications: □
- \*2 The product that the end of driver model designation has "E" is "Position control type". Detail of model designation, refer to P.16.
- \*3 ◇ in number of applicable driver represents the series. For more information about the part number, please refer to P.16.

Torque characteristics (at AC200 V of power voltage <Dotted line represents the torque at 10 % less supply voltage.>)

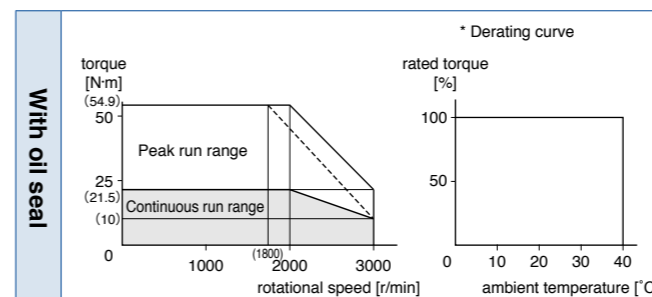

Dimensions

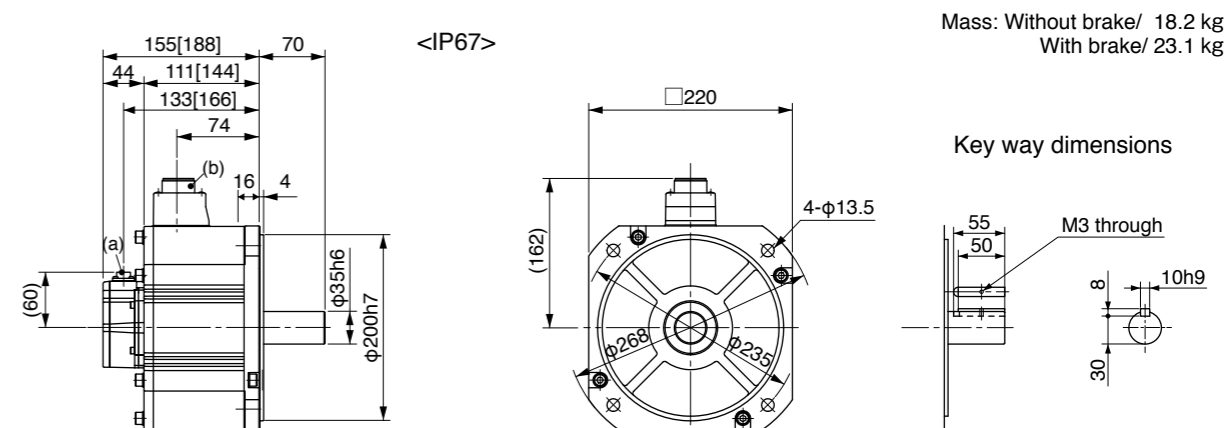

(a) Encoder connector (b) Motor/Brake connector \* Figures in [ ] represent the dimensions with brake. [Unit: mm]

<Cautions> Reduce the moment of inertia ratio if high speed response operation is required. Dimensions are subject to change without notice. Contact us or a dealer for the latest information. Read the Instruction Manual carefully and understand all precautions and remarks before using the products.

Specifications

		AC400 V	
Motor model *1	IP65	MGME094GC□	MGME094SC□
	IP67	MGME094G1□	MGME094S1□
Applicable driver *2	Model No. A5II, A5 series	MDD◇T3420	
	A5IE, A5E series	MDD◇T3420E	-
Frame symbol		D-frame	
Power supply capacity (kVA)	1.8		
Rated output (W)	900		
Rated torque (N·m)	8.59		
Momentary Max. peak torque (N·m)	19.3		
Rated current (A(rms))	3.8		
Max. current (A(o-p))	12		
Regenerative brake frequency (times/min) Note1	Without option	No limit Note2	
	DV0PM20048	No limit Note2	
Rated rotational speed (r/min)	1000		
Max. rotational speed (r/min)	2000		
Moment of inertia of rotor (×10 <sup>-4</sup> kg·m <sup>2</sup> )	Without brake	6.70	
	With brake	7.99	
Recommended moment of inertia ratio of the load and the rotor Note3	10 times or less		
	Rotary encoder specifications Note5	20-bit Incremental	17-bit Absolute
Resolution per single turn		1,048,576	131,072

• Brake specifications (For details, refer to P.183)

(This brake will be released when it is energized.)  
(Do not use this for braking the motor in motion.)

Static friction torque (N·m)	13.7 or more
Engaging time (ms)	100 or less
Releasing time (ms) Note4	50 or less
Exciting current (DC) (A)	0.79±10 %
Releasing voltage (DC) (V)	2 or more
Exciting voltage (DC) (V)	24±2.4

• Permissible load (For details, refer to P.183)

During assembly	Radial load P-direction (N)	980
	Thrust load A-direction (N)	588
	Thrust load B-direction (N)	686
During operation	Radial load P-direction (N)	686
	Thrust load A, B-direction (N)	196

• For details of Note 1 to Note 5, refer to P.182, 183.

• Dimensions of Driver, refer to P.44.

\*1 Motor specifications: □

\*2 The product that the end of driver model designation has "E" is "Position control type". Detail of model designation, refer to P.16.

\*3 ◇ in number of applicable driver represents the series. For more information about the part number, please refer to P.16.

Torque characteristics (at AC400 V of power voltage <Dotted line represents the torque at 10 % less supply voltage.>)

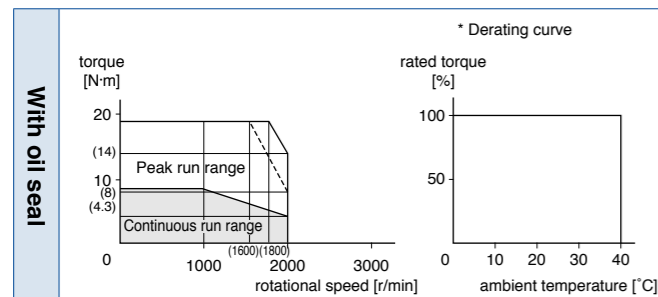

Dimensions

(For IP67 motor, refer to P.139.)

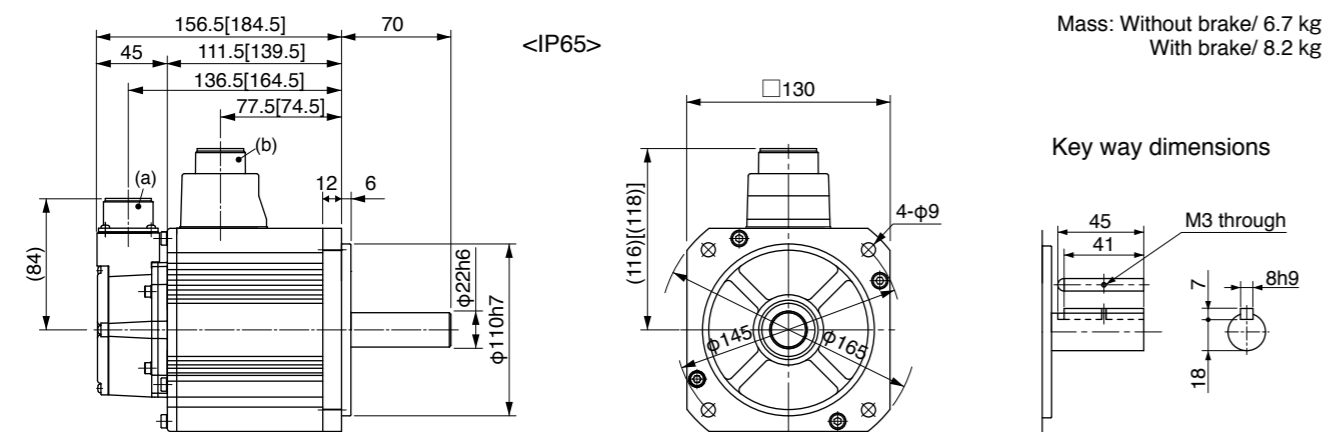

(a) Encoder connector  
(b) Motor/Brake connector

\* Figures in [ ] represent the dimensions with brake.

[Unit: mm]

<Cautions> Reduce the moment of inertia ratio if high speed response operation is required. Dimensions are subject to change without notice. Contact us or a dealer for the latest information. Read the Instruction Manual carefully and understand all precautions and remarks before using the products.

Specifications

		AC400 V	
Motor model *1	IP65	MGME204GC□	MGME204SC□
	IP67	MGME204G1□	MGME204S1□
Applicable driver *2	Model No. A5II, A5 series	MFD◇T5440	
	A5IE, A5E series	MFD◇T5440E	-
Frame symbol		F-frame	
Power supply capacity (kVA)	3.8		
Rated output (W)	2000		
Rated torque (N·m)	19.1		
Momentary Max. peak torque (N·m)	47.7		
Rated current (A(rms))	8.5		
Max. current (A(o-p))	30		
Regenerative brake frequency (times/min) Note1	Without option	No limit Note2	
	DV0PM20049x2	No limit Note2	
Rated rotational speed (r/min)	1000		
Max. rotational speed (r/min)	2000		
Moment of inertia of rotor (×10 <sup>-4</sup> kg·m <sup>2</sup> )	Without brake	30.3	
	With brake	31.4	
Recommended moment of inertia ratio of the load and the rotor Note3	10 times or less		
	Rotary encoder specifications Note5	20-bit Incremental	17-bit Absolute
Resolution per single turn		1,048,576	131,072

• Brake specifications (For details, refer to P.183)

(This brake will be released when it is energized.)  
(Do not use this for braking the motor in motion.)

Static friction torque (N·m)	24.5 or more
Engaging time (ms)	80 or less
Releasing time (ms) Note4	25 or less
Exciting current (DC) (A)	1.3±10 %
Releasing voltage (DC) (V)	2 or more
Exciting voltage (DC) (V)	24±2.4

• Permissible load (For details, refer to P.183)

During assembly	Radial load P-direction (N)	1666
	Thrust load A-direction (N)	784
	Thrust load B-direction (N)	980
During operation	Radial load P-direction (N)	1176
	Thrust load A, B-direction (N)	490

• For details of Note 1 to Note 5, refer to P.182, 183.

• Dimensions of Driver, refer to P.45.

\*1 Motor specifications: □

\*2 The product that the end of driver model designation has "E" is "Position control type". Detail of model designation, refer to P.16.

\*3 ◇ in number of applicable driver represents the series. For more information about the part number, please refer to P.16.

Torque characteristics (at AC400 V of power voltage <Dotted line represents the torque at 10 % less supply voltage.>)

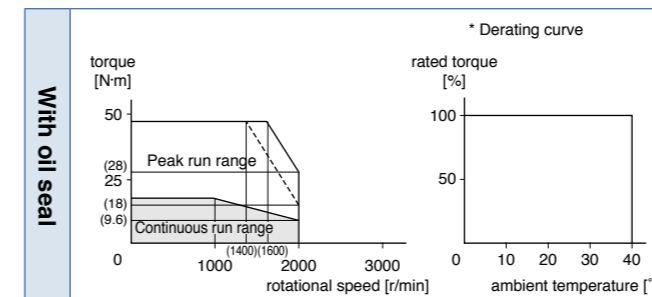

Dimensions

(For IP67 motor, refer to P.139.)

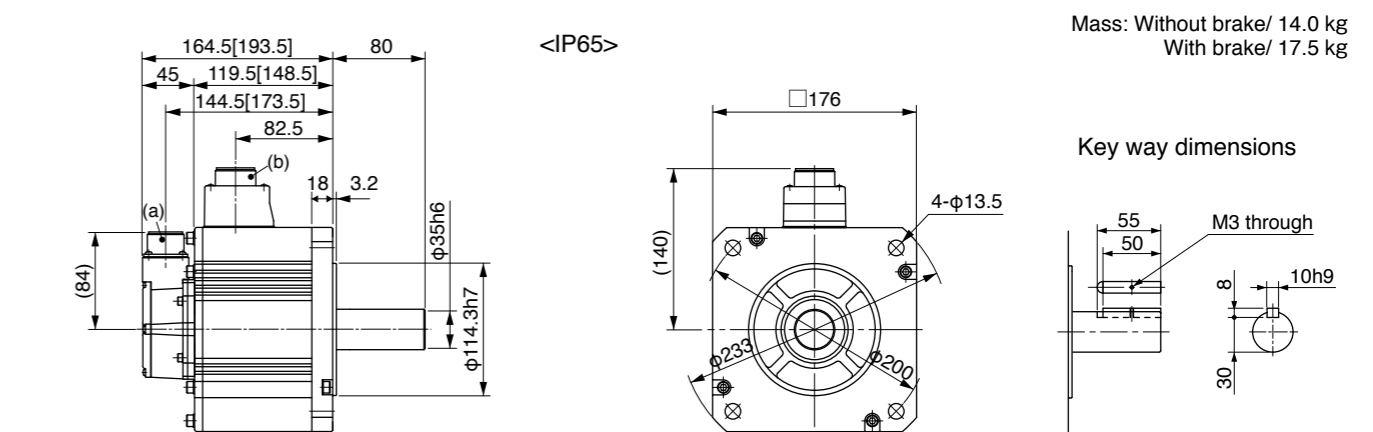

(a) Encoder connector  
(b) Motor/Brake connector

\* Figures in [ ] represent the dimensions with brake.

[Unit: mm]

<Cautions> Reduce the moment of inertia ratio if high speed response operation is required. Dimensions are subject to change without notice. Contact us or a dealer for the latest information. Read the Instruction Manual carefully and understand all precautions and remarks before using the products.



Specifications

		AC400 V	
Motor model *1	IP65	MGME304GC□	MGME304SC□
	IP67	MGME304G1□	MGME304S1□
Applicable driver *2	Model No.	A5II, A5 series	MFD◇TA464
		A5IE, A5E series	MFD◇TA464E
Frame symbol		F-frame	
Power supply capacity (kVA)	4.5		
Rated output (W)	3000		
Rated torque (N·m)	28.7		
Momentary Max. peak torque (N·m)	71.7		
Rated current (A(rms))	11.3		
Max. current (A(o-p))	40		
Regenerative brake frequency (times/min) Note1	Without option	No limit Note2	
	DV0PM20049x2	No limit Note2	
Rated rotational speed (r/min)	1000		
Max. rotational speed (r/min)	2000		
Moment of inertia of rotor (x10 <sup>-4</sup> kg·m <sup>2</sup> )	Without brake	48.4	
	With brake	49.2	
Recommended moment of inertia ratio of the load and the rotor Note3	10 times or less		
Rotary encoder specifications Note5	20-bit Incremental	17-bit Absolute	
	Resolution per single turn	1,048,576	131,072

• **Brake specifications** (For details, refer to P.183)  
 (This brake will be released when it is energized.)  
 (Do not use this for braking the motor in motion.)

Static friction torque (N·m)	58.8 or more
Engaging time (ms)	150 or less
Releasing time (ms) Note4	50 or less
Exciting current (DC) (A)	1.4±10 %
Releasing voltage (DC) (V)	2 or more
Exciting voltage (DC) (V)	24±2.4

• **Permissible load** (For details, refer to P.183)

During assembly	Radial load P-direction (N)	2058
	Thrust load A-direction (N)	980
	Thrust load B-direction (N)	1176
During operation	Radial load P-direction (N)	1470
	Thrust load A, B-direction (N)	490

• For details of Note 1 to Note 5, refer to P.182, 183.  
 • Dimensions of Driver, refer to P.45.

\*1 Motor specifications: □  
 \*2 The product that the end of driver model designation has "E" is "Position control type". Detail of model designation, refer to P.16.  
 \*3 ◇ in number of applicable driver represents the series. For more information about the part number, please refer to P.16.

Torque characteristics (at AC400 V of power voltage <Dotted line represents the torque at 10 % less supply voltage.>)

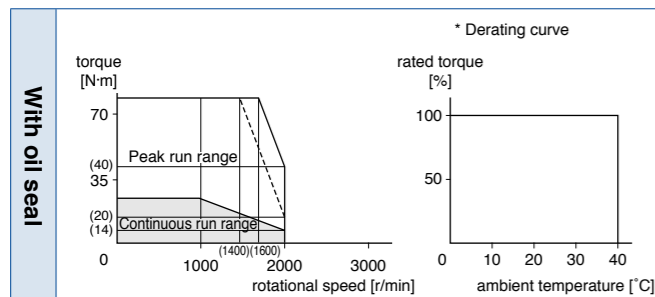

Dimensions

(For IP67 motor, refer to P.139.)

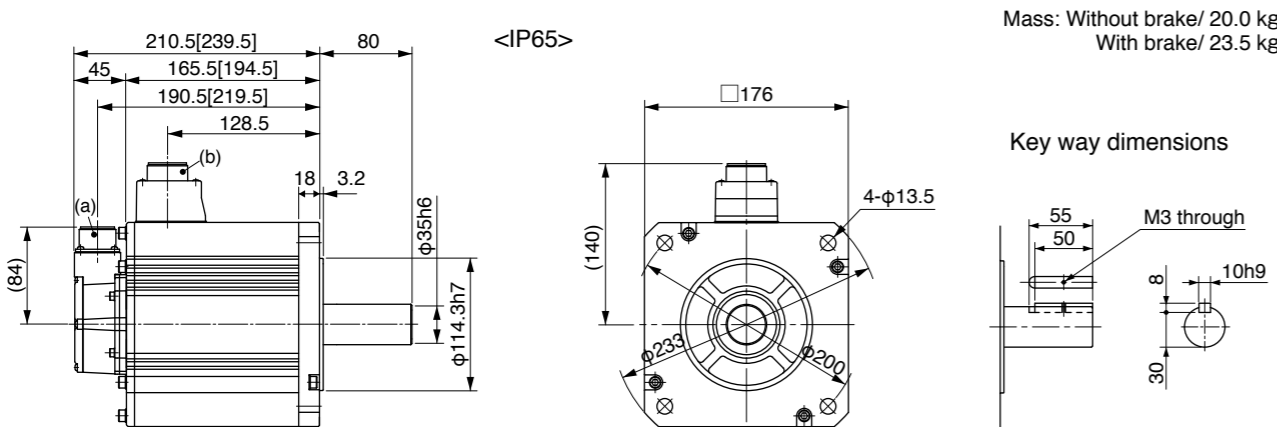

Mass: Without brake/ 20.0 kg  
 With brake/ 23.5 kg

Key way dimensions

(a) Encoder connector  
 (b) Motor/Brake connector

\* Figures in [ ] represent the dimensions with brake.

[Unit: mm]

<Cautions> Reduce the moment of inertia ratio if high speed response operation is required. Dimensions are subject to change without notice. Contact us or a dealer for the latest information. Read the Instruction Manual carefully and understand all precautions and remarks before using the products.

Specifications

		AC400 V	
Motor model *1	IP65	-	-
	IP67	MGME454G1□	MGME454S1□
Applicable driver *2	Model No.	A5II, A5 series	MFD◇TA464
		A5IE, A5E series	MFD◇TA464E
Frame symbol		F-frame	
Power supply capacity (kVA)	7.5		
Rated output (W)	4500		
Rated torque (N·m)	43.0		
Momentary Max. peak torque (N·m)	107		
Rated current (A(rms))	14.8		
Max. current (A(o-p))	55		
Regenerative brake frequency (times/min) Note1	Without option	No limit Note2	
	DV0PM20049x2	No limit Note2	
Rated rotational speed (r/min)	1000		
Max. rotational speed (r/min)	2000		
Moment of inertia of rotor (x10 <sup>-4</sup> kg·m <sup>2</sup> )	Without brake	79.1	
	With brake	84.4	
Recommended moment of inertia ratio of the load and the rotor Note3	10 times or less		
Rotary encoder specifications Note5	20-bit Incremental	17-bit Absolute	
	Resolution per single turn	1,048,576	131,072

• **Brake specifications** (For details, refer to P.183)  
 (This brake will be released when it is energized.)  
 (Do not use this for braking the motor in motion.)

Static friction torque (N·m)	58.8 or more
Engaging time (ms)	150 or less
Releasing time (ms) Note4	50 or less
Exciting current (DC) (A)	1.4±10 %
Releasing voltage (DC) (V)	2 or more
Exciting voltage (DC) (V)	24±2.4

• **Permissible load** (For details, refer to P.183)

During assembly	Radial load P-direction (N)	2058
	Thrust load A-direction (N)	980
	Thrust load B-direction (N)	1176
During operation	Radial load P-direction (N)	1470
	Thrust load A, B-direction (N)	490

• For details of Note 1 to Note 5, refer to P.182, 183.  
 • Dimensions of Driver, refer to P.45.

\*1 Motor specifications: □  
 \*2 The product that the end of driver model designation has "E" is "Position control type". Detail of model designation, refer to P.16.  
 \*3 ◇ in number of applicable driver represents the series. For more information about the part number, please refer to P.16.

Torque characteristics (at AC200 V of power voltage <Dotted line represents the torque at 10 % less supply voltage.>)

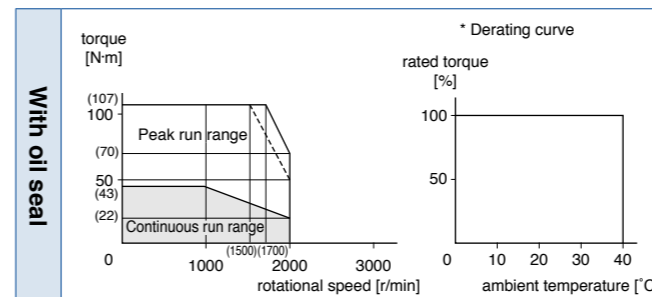

Dimensions

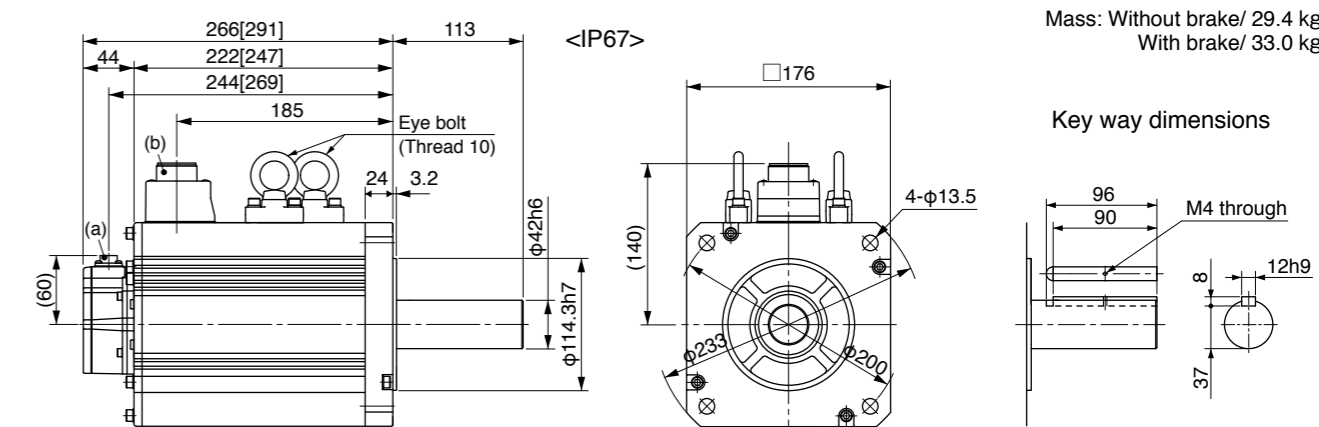

Mass: Without brake/ 29.4 kg  
 With brake/ 33.0 kg

Key way dimensions

(a) Encoder connector  
 (b) Motor/Brake connector

\* Figures in [ ] represent the dimensions with brake.

[Unit: mm]

<Cautions> Reduce the moment of inertia ratio if high speed response operation is required. Dimensions are subject to change without notice. Contact us or a dealer for the latest information. Read the Instruction Manual carefully and understand all precautions and remarks before using the products.

Specifications

		AC400 V	
Motor model *1	IP65	-	-
	IP67	MGME604G1□	MGME604S1□
Applicable driver *2	Model No.	A5II, A5 series	MGD◇TB4A2
	A5IE, A5E series	-	-
	Frame symbol	G-frame	
Power supply capacity (kVA)	9.0		
Rated output (W)	6000		
Rated torque (N·m)	57.3		
Momentary Max. peak torque (N·m)	143		
Rated current (A(rms))	19.4		
Max. current (A(o-p))	74		
Regenerative brake frequency (times/min) Note1	Without option	No limit Note2	
	DV0PM20049x3	No limit Note2	
Rated rotational speed (r/min)	1000		
Max. rotational speed (r/min)	2000		
Moment of inertia of rotor (x10 <sup>-4</sup> kg·m <sup>2</sup> )	Without brake	101	
	With brake	107	
Recommended moment of inertia ratio of the load and the rotor Note3	10 times or less		
Rotary encoder specifications Note5	20-bit Incremental	17-bit Absolute	
	Resolution per single turn	1,048,576	131,072

• Brake specifications (For details, refer to P.183)

(This brake will be released when it is energized.)  
(Do not use this for braking the motor in motion.)

Static friction torque (N·m)	58.8 or more
Engaging time (ms)	150 or less
Releasing time (ms) Note4	50 or less
Exciting current (DC) (A)	1.4±10 %
Releasing voltage (DC) (V)	2 or more
Exciting voltage (DC) (V)	24±2.4

• Permissible load (For details, refer to P.183)

During assembly	Radial load P-direction (N)	2058
	Thrust load A-direction (N)	980
	Thrust load B-direction (N)	1176
During operation	Radial load P-direction (N)	1764
	Thrust load A, B-direction (N)	588

• For details of Note 1 to Note 5, refer to P.182, 183.

• Dimensions of Driver, refer to P.46.

\*1 Motor specifications: □

\*2 The product that the end of driver model designation has "E" is "Position control type". Detail of model designation, refer to P.16.

\*3 ◇ in number of applicable driver represents the series. For more information about the part number, please refer to P.16.

Torque characteristics (at AC200 V of power voltage <Dotted line represents the torque at 10 % less supply voltage.>)

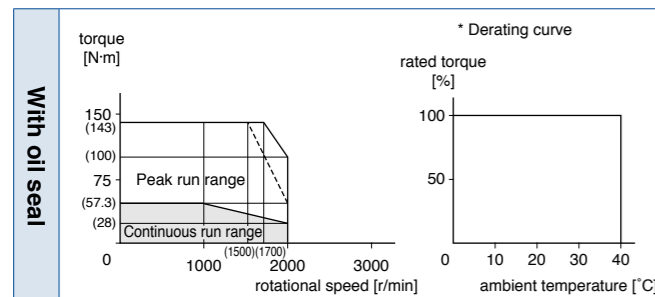

Dimensions

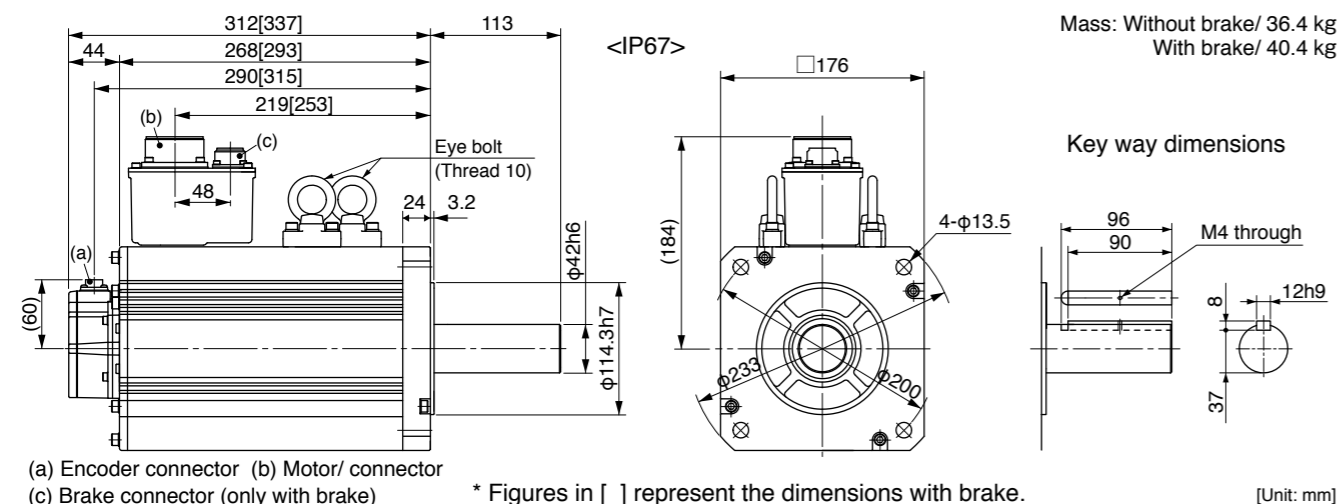

(a) Encoder connector (b) Motor/ connector (c) Brake connector (only with brake) \* Figures in [ ] represent the dimensions with brake. <Cautions> Reduce the moment of inertia ratio if high speed response operation is required. Dimensions are subject to change without notice. Contact us or a dealer for the latest information. Read the Instruction Manual carefully and understand all precautions and remarks before using the products.

Specifications

		AC400 V	
Motor model *1	IP65	MHME104GC□	MHME104SC□
	IP67	MHME104G1□	MHME104S1□
Applicable driver *2	Model No.	A5II, A5 series	MDD◇T2412
	A5IE, A5E series	MDD◇T2412E	-
	Frame symbol	D-frame	
Power supply capacity (kVA)	1.8		
Rated output (W)	1000		
Rated torque (N·m)	4.77		
Momentary Max. peak torque (N·m)	14.3		
Rated current (A(rms))	2.9		
Max. current (A(o-p))	12		
Regenerative brake frequency (times/min) Note1	Without option	83	
	DV0PM20048	No limit Note2	
Rated rotational speed (r/min)	2000		
Max. rotational speed (r/min)	3000		
Moment of inertia of rotor (x10 <sup>-4</sup> kg·m <sup>2</sup> )	Without brake	24.7	
	With brake	26.0	
Recommended moment of inertia ratio of the load and the rotor Note3	5 times or less		
Rotary encoder specifications Note5	20-bit Incremental	17-bit Absolute	
	Resolution per single turn	1,048,576	131,072

• Brake specifications (For details, refer to P.183)

(This brake will be released when it is energized.)  
(Do not use this for braking the motor in motion.)

Static friction torque (N·m)	4.9 or more
Engaging time (ms)	80 or less
Releasing time (ms) Note4	70 or less
Exciting current (DC) (A)	0.59±10 %
Releasing voltage (DC) (V)	2 or more
Exciting voltage (DC) (V)	24±2.4

• Permissible load (For details, refer to P.183)

During assembly	Radial load P-direction (N)	980
	Thrust load A-direction (N)	588
	Thrust load B-direction (N)	686
During operation	Radial load P-direction (N)	490
	Thrust load A, B-direction (N)	196

• For details of Note 1 to Note 5, refer to P.182, 183.

• Dimensions of Driver, refer to P.44.

\*1 Motor specifications: □

\*2 The product that the end of driver model designation has "E" is "Position control type". Detail of model designation, refer to P.16.

\*3 ◇ in number of applicable driver represents the series. For more information about the part number, please refer to P.16.

Torque characteristics (at AC400 V of power voltage <Dotted line represents the torque at 10 % less supply voltage.>)

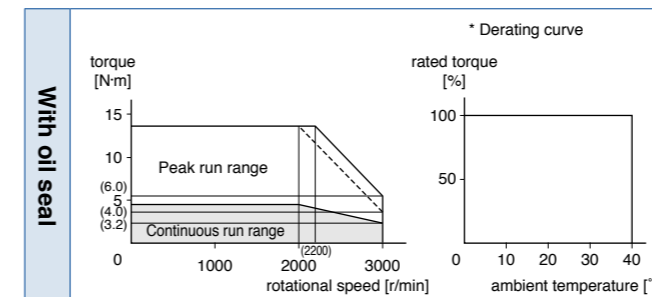

Dimensions

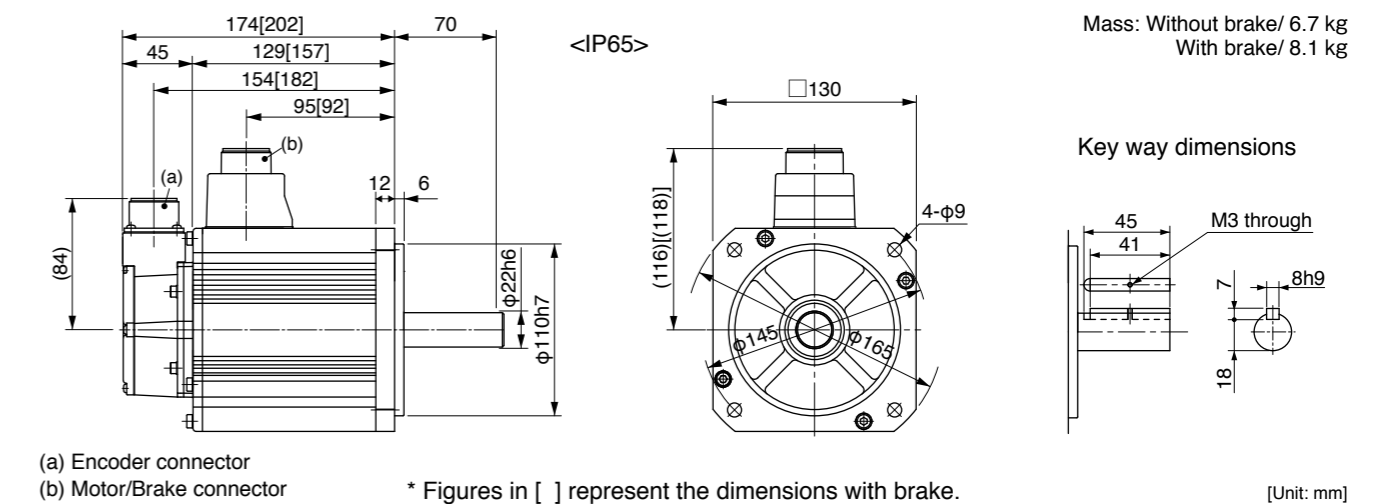

(a) Encoder connector (b) Motor/Brake connector \* Figures in [ ] represent the dimensions with brake. <Cautions> Reduce the moment of inertia ratio if high speed response operation is required. Dimensions are subject to change without notice. Contact us or a dealer for the latest information. Read the Instruction Manual carefully and understand all precautions and remarks before using the products.

Specifications

		AC400 V	
Motor model <sup>*1</sup>	IP65	MHME154GC□	MHME154SC□
	IP67	MHME154G1□	MHME154S1□
Applicable driver <sup>*2</sup>	Model No. A5II, A5 series	MDD◇T3420	
	A5IE, A5E series	MDD◇T3420E	—
Frame symbol		D-frame	
Power supply capacity (kVA)		2.3	
Rated output (W)		1500	
Rated torque (N·m)		7.16	
Momentary Max. peak torque (N·m)		21.5	
Rated current (A(rms))		4.7	
Max. current (A(o-p))		20	
Regenerative brake frequency (times/min) <sup>Note1</sup>	Without option	22	
	DV0PM20048	130	
Rated rotational speed (r/min)		2000	
Max. rotational speed (r/min)		3000	
Moment of inertia of rotor (×10 <sup>-4</sup> kg·m <sup>2</sup> )	Without brake	37.1	
	With brake	38.4	
Recommended moment of inertia ratio of the load and the rotor <sup>Note3</sup>		5 times or less	
Rotary encoder specifications <sup>Note5</sup>	20-bit Incremental		17-bit Absolute
	Resolution per single turn	1,048,576	131,072

• **Brake specifications** (For details, refer to P.183)  
 (This brake will be released when it is energized.)  
 (Do not use this for braking the motor in motion.)

Static friction torque (N·m)	13.7 or more
Engaging time (ms)	100 or less
Releasing time (ms) <sup>Note4</sup>	50 or less
Exciting current (DC) (A)	0.79±10 %
Releasing voltage (DC) (V)	2 or more
Exciting voltage (DC) (V)	24±2.4

• **Permissible load** (For details, refer to P.183)

During assembly	Radial load P-direction (N)	980
	Thrust load A-direction (N)	588
	Thrust load B-direction (N)	686
During operation	Radial load P-direction (N)	490
	Thrust load A, B-direction (N)	196

• For details of Note 1 to Note 5, refer to P.182, 183.  
 • Dimensions of Driver, refer to P.44.

- \*1 Motor specifications: □
- \*2 The product that the end of driver model designation has "E" is "Position control type". Detail of model designation, refer to P.16.
- \*3 ◇ in number of applicable driver represents the series. For more information about the part number, please refer to P.16.

Torque characteristics (at AC400 V of power voltage <Dotted line represents the torque at 10 % less supply voltage.>)

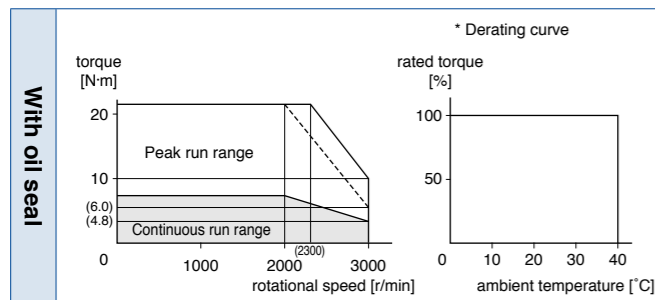

Dimensions

(For IP67 motor, refer to P.140.)

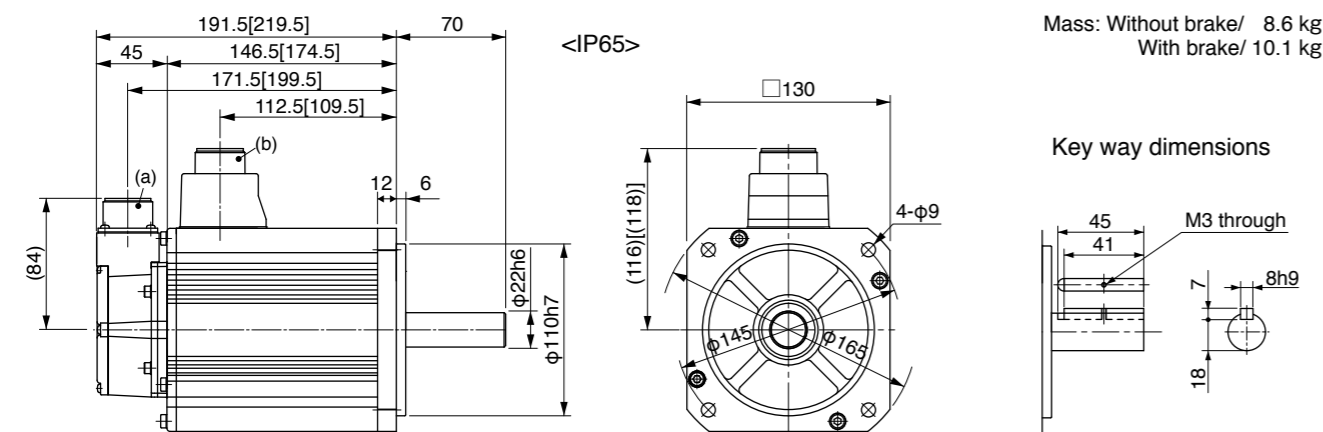

(a) Encoder connector (b) Motor/Brake connector \* Figures in [ ] represent the dimensions with brake. [Unit: mm]

<Cautions> Reduce the moment of inertia ratio if high speed response operation is required. Dimensions are subject to change without notice. Contact us or a dealer for the latest information. Read the Instruction Manual carefully and understand all precautions and remarks before using the products.

Specifications

		AC400 V	
Motor model <sup>*1</sup>	IP65	MHME204GC□	MHME204SC□
	IP67	MHME204G1□	MHME204S1□
Applicable driver <sup>*2</sup>	Model No. A5II, A5 series	MED◇T4430	
	A5IE, A5E series	MED◇T4430E	—
Frame symbol		E-frame	
Power supply capacity (kVA)		3.3	
Rated output (W)		2000	
Rated torque (N·m)		9.55	
Momentary Max. peak torque (N·m)		28.6	
Rated current (A(rms))		5.5	
Max. current (A(o-p))		24	
Regenerative brake frequency (times/min) <sup>Note1</sup>	Without option	45	
	DV0PM20048	142	
Rated rotational speed (r/min)		2000	
Max. rotational speed (r/min)		3000	
Moment of inertia of rotor (×10 <sup>-4</sup> kg·m <sup>2</sup> )	Without brake	57.8	
	With brake	59.6	
Recommended moment of inertia ratio of the load and the rotor <sup>Note3</sup>		5 times or less	
Rotary encoder specifications <sup>Note5</sup>	20-bit Incremental		17-bit Absolute
	Resolution per single turn	1,048,576	131,072

• **Brake specifications** (For details, refer to P.183)  
 (This brake will be released when it is energized.)  
 (Do not use this for braking the motor in motion.)

Static friction torque (N·m)	24.5 or more
Engaging time (ms)	80 or less
Releasing time (ms) <sup>Note4</sup>	25 or less
Exciting current (DC) (A)	1.3±10 %
Releasing voltage (DC) (V)	2 or more
Exciting voltage (DC) (V)	24±2.4

• **Permissible load** (For details, refer to P.183)

During assembly	Radial load P-direction (N)	1666
	Thrust load A-direction (N)	784
	Thrust load B-direction (N)	980
During operation	Radial load P-direction (N)	784
	Thrust load A, B-direction (N)	343

• For details of Note 1 to Note 5, refer to P.182, 183.  
 • Dimensions of Driver, refer to P.45.

- \*1 Motor specifications: □
- \*2 The product that the end of driver model designation has "E" is "Position control type". Detail of model designation, refer to P.16.
- \*3 ◇ in number of applicable driver represents the series. For more information about the part number, please refer to P.16.

Torque characteristics (at AC400 V of power voltage <Dotted line represents the torque at 10 % less supply voltage.>)

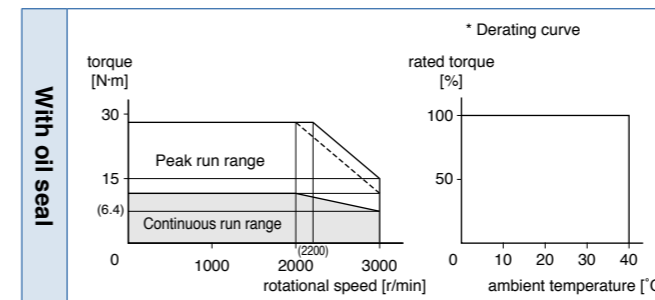

Dimensions

(For IP67 motor, refer to P.140.)

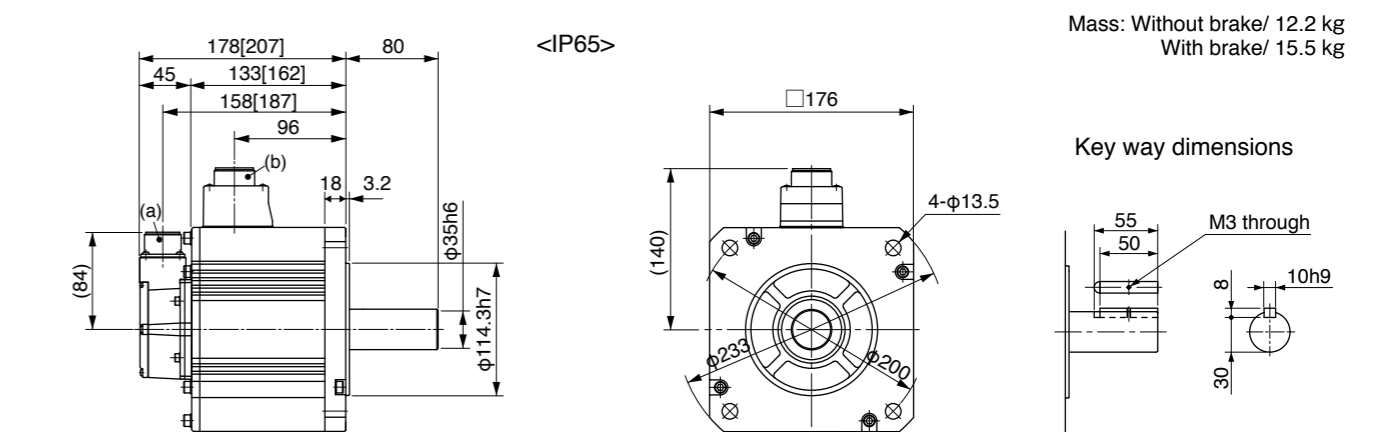

(a) Encoder connector (b) Motor/Brake connector \* Figures in [ ] represent the dimensions with brake. [Unit: mm]

<Cautions> Reduce the moment of inertia ratio if high speed response operation is required. Dimensions are subject to change without notice. Contact us or a dealer for the latest information. Read the Instruction Manual carefully and understand all precautions and remarks before using the products.

Specifications

		AC400 V	
Motor model <sup>*1</sup>	IP65	MHME304GC□	MHME304SC□
	IP67	MHME304G1□	MHME304S1□
Applicable driver <sup>*2</sup>	Model No.	A5II, A5 series	MFD◇T5440
	A5IE, A5E series	MFD◇T5440E	-
Frame symbol		F-frame	
Power supply capacity (kVA)	4.5		
Rated output (W)	3000		
Rated torque (N·m)	14.3		
Momentary Max. peak torque (N·m)	43.0		
Rated current (A(rms))	8.0		
Max. current (A(o-p))	34		
Regenerative brake frequency (times/min) <sup>Note1</sup>	Without option	19	
	DV0PM20049x2	142	
Rated rotational speed (r/min)	2000		
Max. rotational speed (r/min)	3000		
Moment of inertia of rotor ( $\times 10^{-4}$ kg·m <sup>2</sup> )	Without brake	90.5	
	With brake	92.1	
Recommended moment of inertia ratio of the load and the rotor <sup>Note3</sup>	5 times or less		
Rotary encoder specifications <sup>Note5</sup>	20-bit Incremental	17-bit Absolute	
	Resolution per single turn	1,048,576	131,072

• **Brake specifications** (For details, refer to P.183)  
 (This brake will be released when it is energized.)  
 (Do not use this for braking the motor in motion.)

Static friction torque (N·m)	24.5 or more
Engaging time (ms)	80 or less
Releasing time (ms) <sup>Note4</sup>	25 or less
Exciting current (DC) (A)	1.3±10 %
Releasing voltage (DC) (V)	2 or more
Exciting voltage (DC) (V)	24±2.4

• **Permissible load** (For details, refer to P.183)

During assembly	Radial load P-direction (N)	1666
	Thrust load A-direction (N)	784
	Thrust load B-direction (N)	980
During operation	Radial load P-direction (N)	784
	Thrust load A, B-direction (N)	343

• For details of Note 1 to Note 5, refer to P.182, 183.  
 • Dimensions of Driver, refer to P.45.

- \*1 Motor specifications: □
- \*2 The product that the end of driver model designation has "E" is "Position control type". Detail of model designation, refer to P.16.
- \*3 ◇ in number of applicable driver represents the series. For more information about the part number, please refer to P.16.

Torque characteristics (at AC400 V of power voltage <Dotted line represents the torque at 10 % less supply voltage.>)

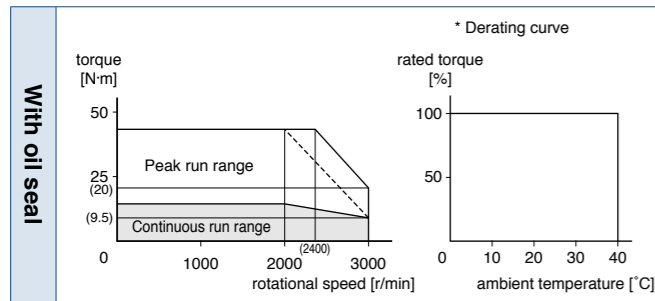

Dimensions

(For IP67 motor, refer to P.140.)

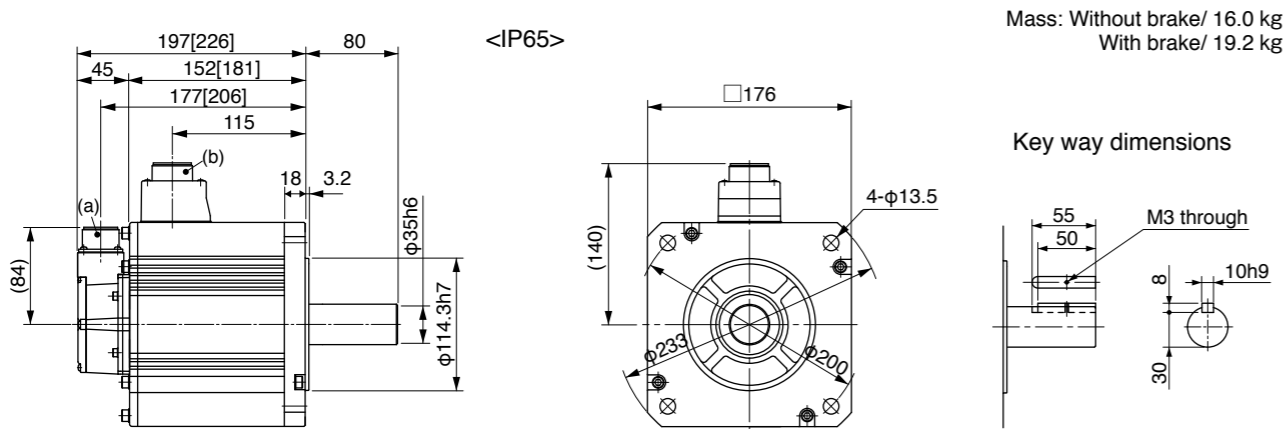

(a) Encoder connector (b) Motor/Brake connector \* Figures in [ ] represent the dimensions with brake. [Unit: mm]

<Cautions> Reduce the moment of inertia ratio if high speed response operation is required. Dimensions are subject to change without notice. Contact us or a dealer for the latest information. Read the Instruction Manual carefully and understand all precautions and remarks before using the products.

Specifications

		AC400 V	
Motor model <sup>*1</sup>	IP65	MHME404GC□	MHME404SC□
	IP67	MHME404G1□	MHME404S1□
Applicable driver <sup>*2</sup>	Model No.	A5II, A5 series	MFD◇TA464
	A5IE, A5E series	MFD◇TA464E	-
Frame symbol		F-frame	
Power supply capacity (kVA)	6.8		
Rated output (W)	4000		
Rated torque (N·m)	19.1		
Momentary Max. peak torque (N·m)	57.3		
Rated current (A(rms))	10.5		
Max. current (A(o-p))	45		
Regenerative brake frequency (times/min) <sup>Note1</sup>	Without option	17	
	DV0PM20049x2	125	
Rated rotational speed (r/min)	2000		
Max. rotational speed (r/min)	3000		
Moment of inertia of rotor ( $\times 10^{-4}$ kg·m <sup>2</sup> )	Without brake	112	
	With brake	114	
Recommended moment of inertia ratio of the load and the rotor <sup>Note3</sup>	5 times or less		
Rotary encoder specifications <sup>Note5</sup>	20-bit Incremental	17-bit Absolute	
	Resolution per single turn	1,048,576	131,072

• **Brake specifications** (For details, refer to P.183)  
 (This brake will be released when it is energized.)  
 (Do not use this for braking the motor in motion.)

Static friction torque (N·m)	24.5 or more
Engaging time (ms)	80 or less
Releasing time (ms) <sup>Note4</sup>	25 or less
Exciting current (DC) (A)	1.3±10 %
Releasing voltage (DC) (V)	2 or more
Exciting voltage (DC) (V)	24±2.4

• **Permissible load** (For details, refer to P.183)

During assembly	Radial load P-direction (N)	1666
	Thrust load A-direction (N)	784
	Thrust load B-direction (N)	980
During operation	Radial load P-direction (N)	784
	Thrust load A, B-direction (N)	343

• For details of Note 1 to Note 5, refer to P.182, 183.  
 • Dimensions of Driver, refer to P.45.

- \*1 Motor specifications: □
- \*2 The product that the end of driver model designation has "E" is "Position control type". Detail of model designation, refer to P.16.
- \*3 ◇ in number of applicable driver represents the series. For more information about the part number, please refer to P.16.

Torque characteristics (at AC400 V of power voltage <Dotted line represents the torque at 10 % less supply voltage.>)

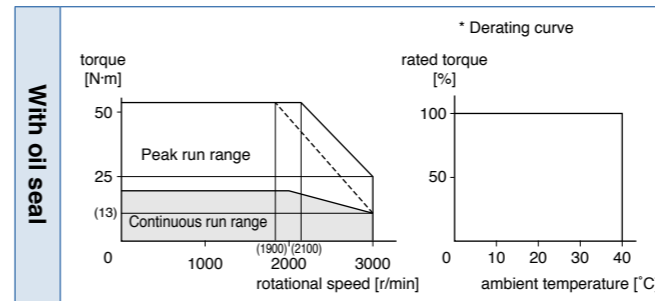

Dimensions

(For IP67 motor, refer to P.140.)

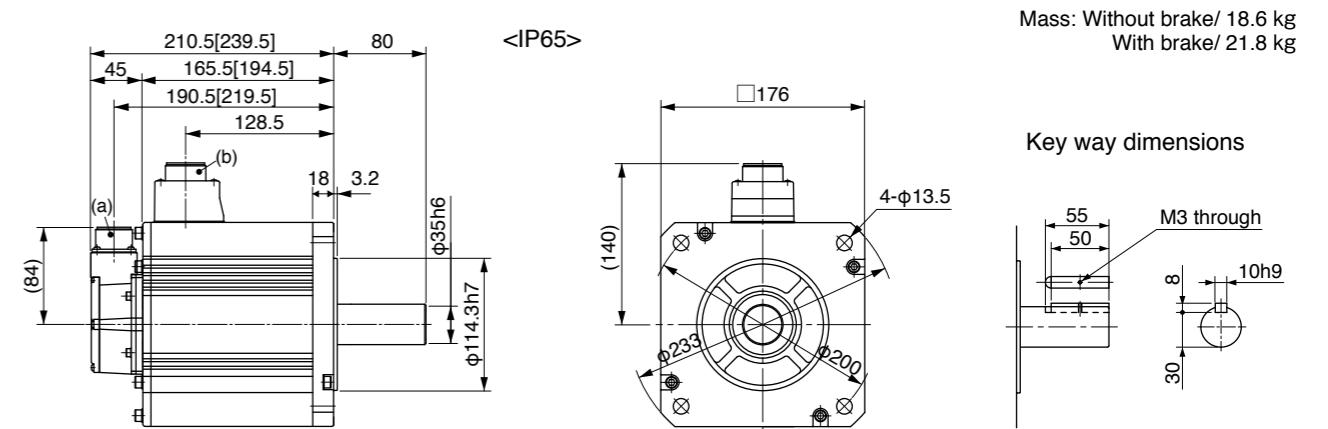

(a) Encoder connector (b) Motor/Brake connector \* Figures in [ ] represent the dimensions with brake. [Unit: mm]

<Cautions> Reduce the moment of inertia ratio if high speed response operation is required. Dimensions are subject to change without notice. Contact us or a dealer for the latest information. Read the Instruction Manual carefully and understand all precautions and remarks before using the products.

Specifications

		AC400 V	
Motor model *1	IP65	MHME504GC □	MHME504SC □
	IP67	MHME504G1 □	MHME504S1 □
Applicable driver *2	Model No. A5II, A5 series	MFD ◇ TA464	
	A5IE, A5E series	MFD ◇ TA464E	-
Frame symbol		F-frame	
Power supply capacity (kVA)		7.5	
Rated output (W)		5000	
Rated torque (N·m)		23.9	
Momentary Max. peak torque (N·m)		71.6	
Rated current (A(rms))		13.0	
Max. current (A(o-p))		55	
Regenerative brake frequency (times/min) Note1	Without option	10	
	DV0PM20049x2	76	
Rated rotational speed (r/min)		2000	
Max. rotational speed (r/min)		3000	
Moment of inertia of rotor ( $\times 10^{-4}$ kg·m <sup>2</sup> )	Without brake	162	
	With brake	164	
Recommended moment of inertia ratio of the load and the rotor Note3		5 times or less	
Rotary encoder specifications Note5	20-bit Incremental		17-bit Absolute
	Resolution per single turn	1,048,576	131,072

• Brake specifications (For details, refer to P.183)

(This brake will be released when it is energized.)  
(Do not use this for braking the motor in motion.)

Static friction torque (N·m)	24.5 or more
Engaging time (ms)	80 or less
Releasing time (ms) Note4	25 or less
Exciting current (DC) (A)	1.3±10 %
Releasing voltage (DC) (V)	2 or more
Exciting voltage (DC) (V)	24±2.4

• Permissible load (For details, refer to P.183)

During assembly	Radial load P-direction (N)	1666
	Thrust load A-direction (N)	784
	Thrust load B-direction (N)	980
During operation	Radial load P-direction (N)	784
	Thrust load A, B-direction (N)	343

• For details of Note 1 to Note 5, refer to P.182, 183.

• Dimensions of Driver, refer to P.45.

\*1 Motor specifications: □

\*2 The product that the end of driver model designation has "E" is "Position control type". Detail of model designation, refer to P.16.

\*3 ◇ in number of applicable driver represents the series. For more information about the part number, please refer to P.16.

Torque characteristics (at AC400 V of power voltage <Dotted line represents the torque at 10 % less supply voltage.>)

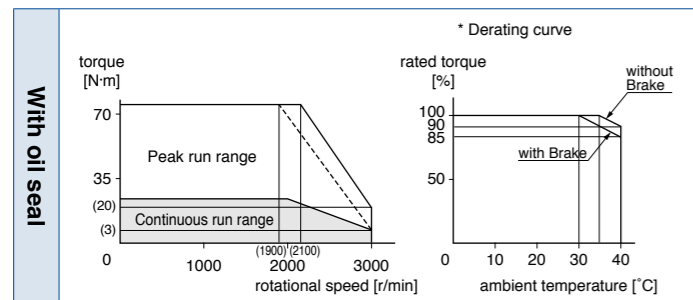

Dimensions

(For IP67 motor, refer to P.140.)

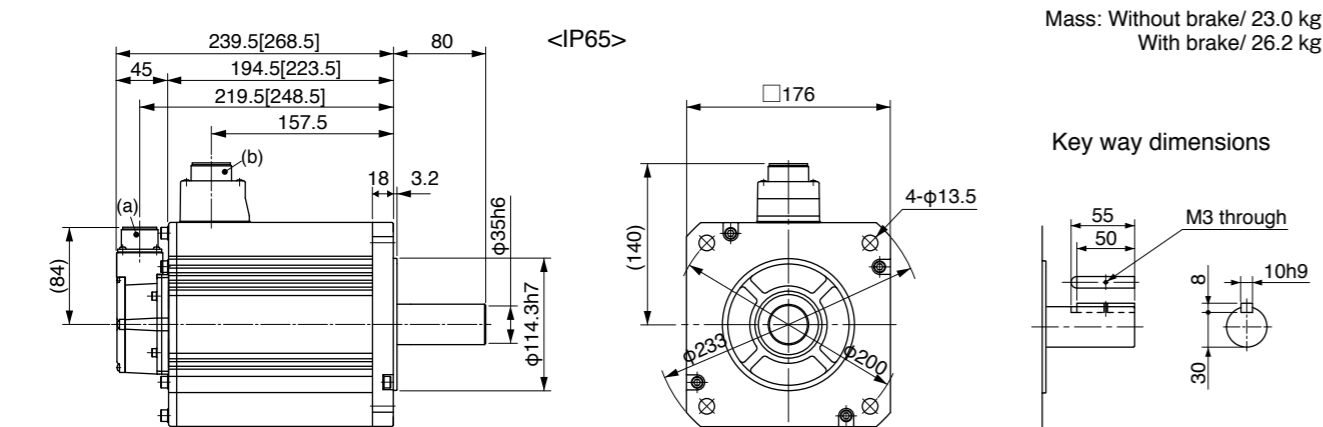

(a) Encoder connector  
(b) Motor/Brake connector

\* Figures in [ ] represent the dimensions with brake.

[Unit: mm]

<Cautions> Reduce the moment of inertia ratio if high speed response operation is required. Dimensions are subject to change without notice. Contact us or a dealer for the latest information. Read the Instruction Manual carefully and understand all precautions and remarks before using the products.

Specifications

		AC400 V	
Motor model *1	IP65	-	-
	IP67	MHME754G1 □	MHME754S1 □
Applicable driver *2	Model No. A5II, A5 series	MGD ◇ TB4A2	
	A5IE, A5E series	-	-
Frame symbol		G-frame	
Power supply capacity (kVA)		9.0	
Rated output (W)		7500	
Rated torque (N·m)		47.8	
Momentary Max. peak torque (N·m)		119	
Rated current (A(rms))		22.0	
Max. current (A(o-p))		83	
Regenerative brake frequency (times/min) Note1	Without option	No limit Note2	
	DV0PM20049x3	No limit Note2	
Rated rotational speed (r/min)		1500	
Max. rotational speed (r/min)		3000	
Moment of inertia of rotor ( $\times 10^{-4}$ kg·m <sup>2</sup> )	Without brake	273	
	With brake	279	
Recommended moment of inertia ratio of the load and the rotor Note3		5 times or less	
Rotary encoder specifications Note5	20-bit Incremental		17-bit Absolute
	Resolution per single turn	1,048,576	131,072

• Brake specifications (For details, refer to P.183)

(This brake will be released when it is energized.)  
(Do not use this for braking the motor in motion.)

Static friction torque (N·m)	58.8 or more
Engaging time (ms)	150 or less
Releasing time (ms) Note4	50 or less
Exciting current (DC) (A)	1.4±10 %
Releasing voltage (DC) (V)	2 or more
Exciting voltage (DC) (V)	24±2.4

• Permissible load (For details, refer to P.183)

During assembly	Radial load P-direction (N)	2058
	Thrust load A-direction (N)	980
	Thrust load B-direction (N)	1176
During operation	Radial load P-direction (N)	1176
	Thrust load A, B-direction (N)	490

• For details of Note 1 to Note 5, refer to P.182, 183.

• Dimensions of Driver, refer to P.46.

\*1 Motor specifications: □

\*2 The product that the end of driver model designation has "E" is "Position control type". Detail of model designation, refer to P.16.

\*3 ◇ in number of applicable driver represents the series. For more information about the part number, please refer to P.16.

Torque characteristics (at AC400 V of power voltage <Dotted line represents the torque at 10 % less supply voltage.>)

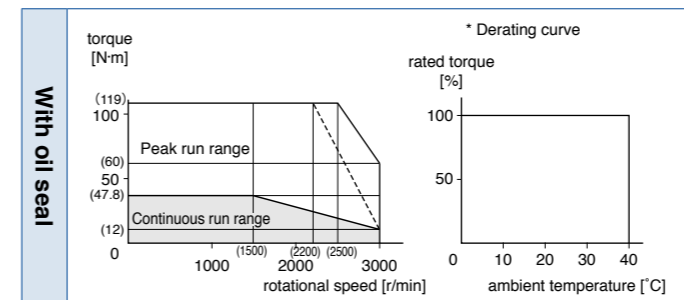

Dimensions

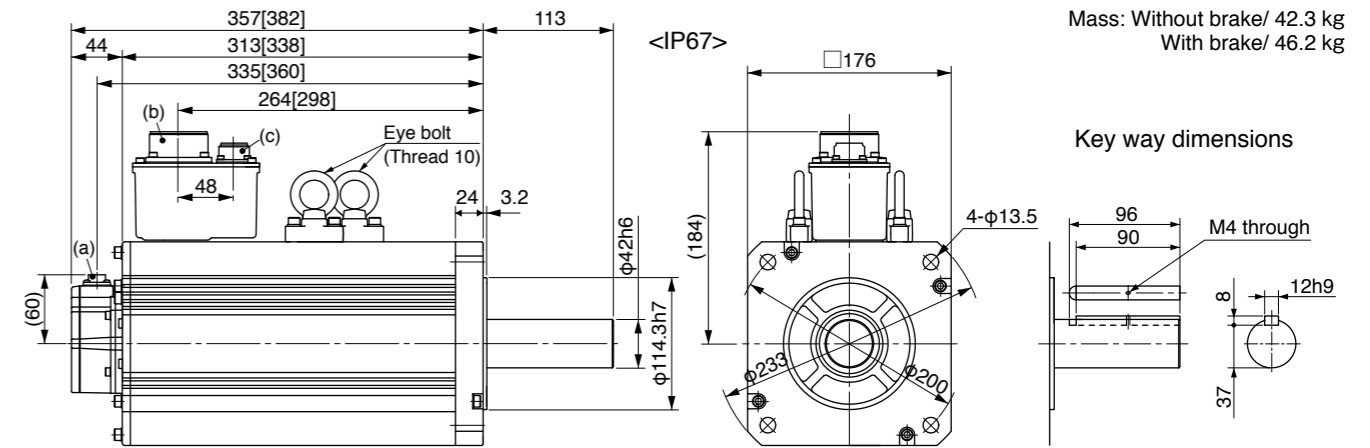

(a) Encoder connector (b) Motor/ connector  
(c) Brake connector (only with brake)

\* Figures in [ ] represent the dimensions with brake.

[Unit: mm]

<Cautions> Reduce the moment of inertia ratio if high speed response operation is required. Dimensions are subject to change without notice. Contact us or a dealer for the latest information. Read the Instruction Manual carefully and understand all precautions and remarks before using the products.

• MSME084□□1\*

[Unit: mm]

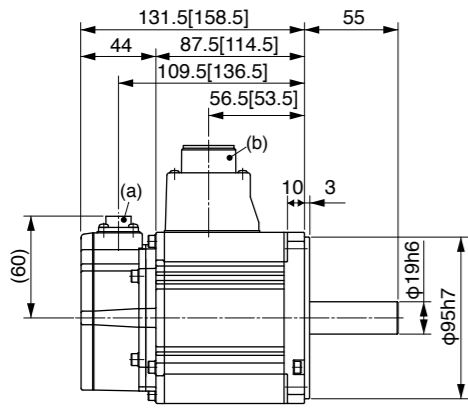

(a) Encoder connector  
(b) Motor/Brake connector

\* Figures in [ ] represent the dimensions with brake.

• MSME10□□1\*

[Unit: mm]

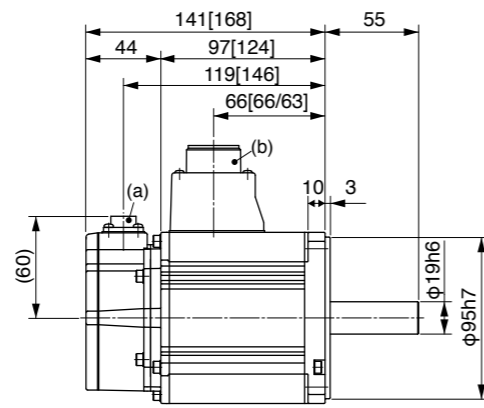

(a) Encoder connector (b) Motor/Brake connector

\* Figures in [ ] represent the dimensions with brake. If you find two figures in [ ], left figure is for 200 V and right figure is for 400 V.

• MSME15□□1\*

[Unit: mm]

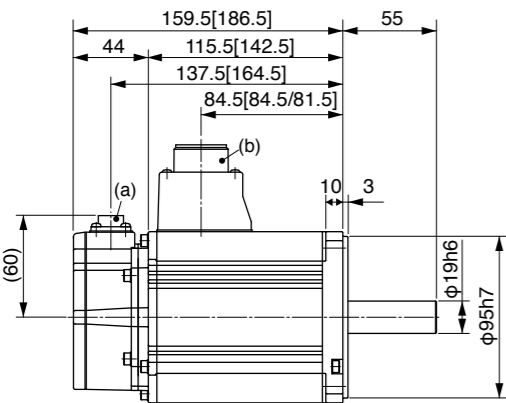

(a) Encoder connector (b) Motor/Brake connector

\* Figures in [ ] represent the dimensions with brake. If you find two figures in [ ], left figure is for 200 V and right figure is for 400 V.

• MSME20□□1\*

[Unit: mm]

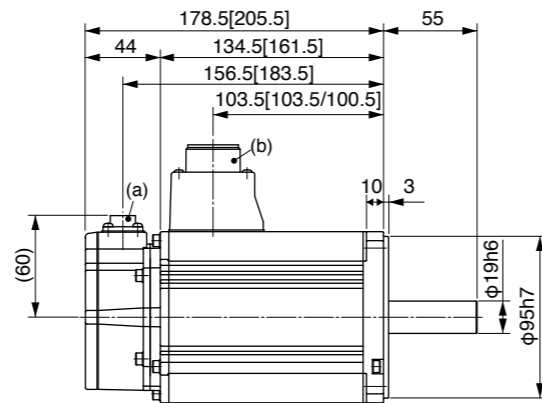

(a) Encoder connector (b) Motor/Brake connector

\* Figures in [ ] represent the dimensions with brake. If you find two figures in [ ], left figure is for 200 V and right figure is for 400 V.

• MSME30□□1\*

[Unit: mm]

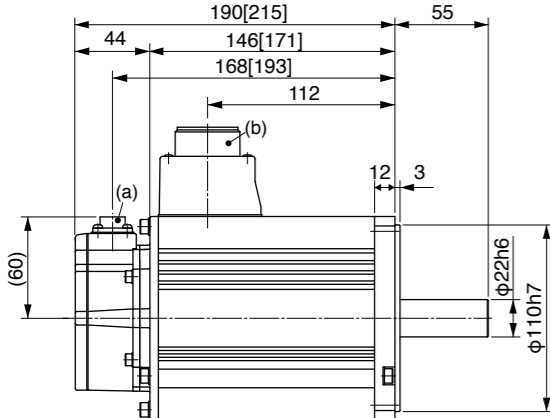

(a) Encoder connector  
(b) Motor/Brake connector

\* Figures in [ ] represent the dimensions with brake.

• MSME40□□1\*

[Unit: mm]

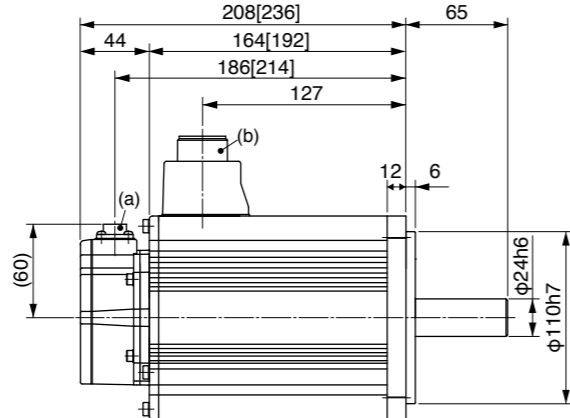

(a) Encoder connector  
(b) Motor/Brake connector

\* Figures in [ ] represent the dimensions with brake.

\* For motor specifications, refer to IP65 motor page.

• MSME50□□1\*

[Unit: mm]

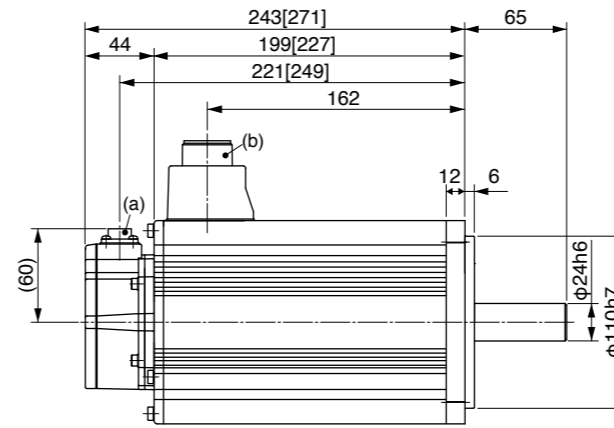

(a) Encoder connector  
(b) Motor/Brake connector

\* Figures in [ ] represent the dimensions with brake.

• MDME044□□1\*

[Unit: mm]

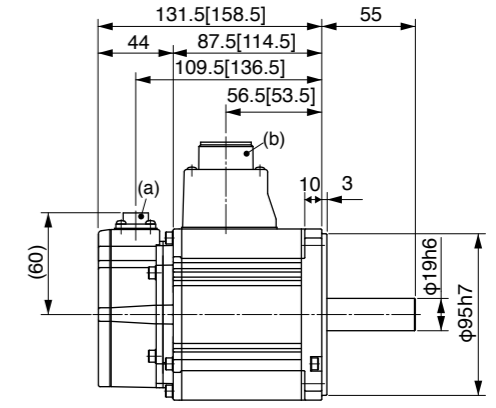

(a) Encoder connector  
(b) Motor/Brake connector

\* Figures in [ ] represent the dimensions with brake.

• MDME064□□1\*

[Unit: mm]

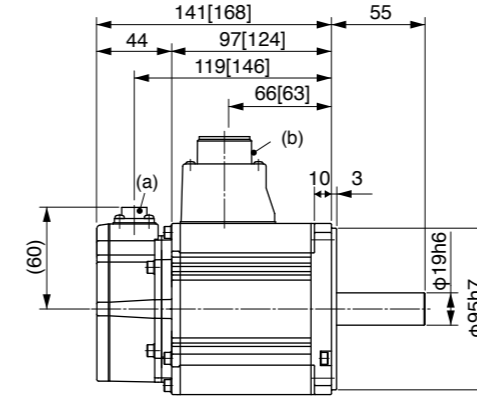

(a) Encoder connector  
(b) Motor/Brake connector

\* Figures in [ ] represent the dimensions with brake.

• MDME10□□1\*

[Unit: mm]

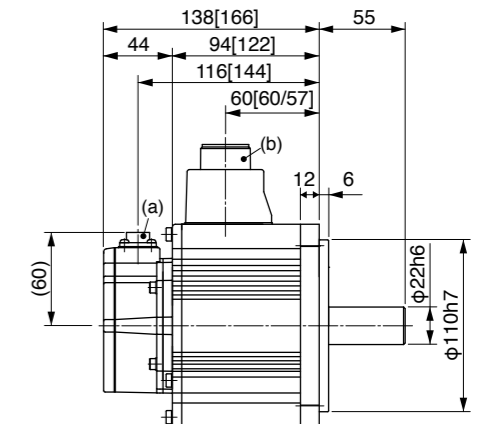

(a) Encoder connector (b) Motor/Brake connector

\* Figures in [ ] represent the dimensions with brake. If you find two figures in [ ], left figure is for 200 V and right figure is for 400 V.

• MDME15□□1\*

[Unit: mm]

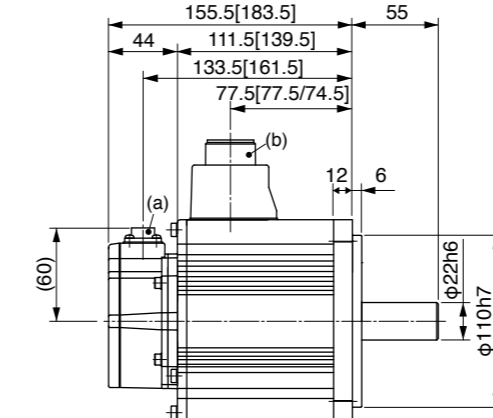

(a) Encoder connector (b) Motor/Brake connector

\* Figures in [ ] represent the dimensions with brake. If you find two figures in [ ], left figure is for 200 V and right figure is for 400 V.

• MDME20□□1\*

[Unit: mm]

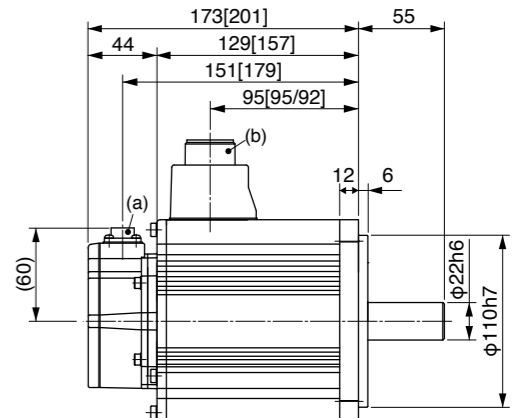

(a) Encoder connector (b) Motor/Brake connector

\* Figures in [ ] represent the dimensions with brake. If you find two figures in [ ], left figure is for 200 V and right figure is for 400 V.

\* For motor specifications, refer to IP65 motor page.

• MDME30□□1\*

[Unit: mm]

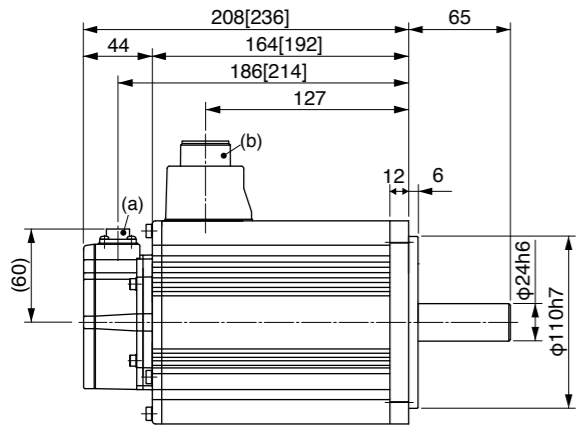

(a) Encoder connector  
(b) Motor/Brake connector

\* Figures in [ ] represent the dimensions with brake.

• MDME40□□1\*

[Unit: mm]

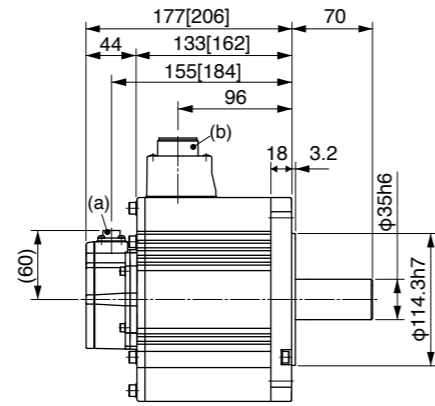

(a) Encoder connector  
(b) Motor/Brake connector

\* Figures in [ ] represent the dimensions with brake.

• MDME50□□1\*

[Unit: mm]

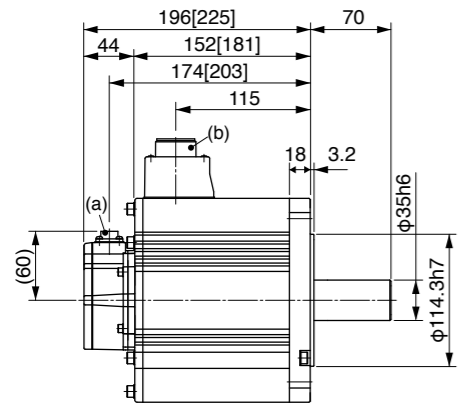

(a) Encoder connector  
(b) Motor/Brake connector

\* Figures in [ ] represent the dimensions with brake.

• MGME09□□1\*

[Unit: mm]

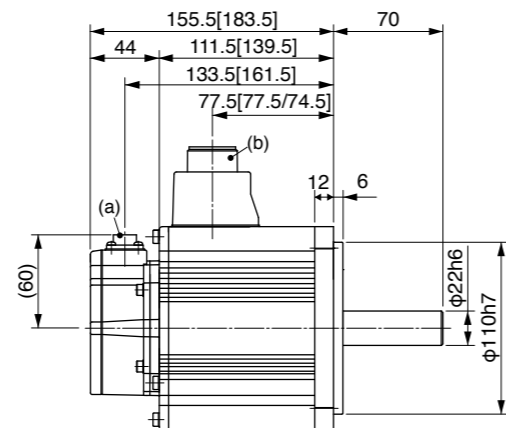

(a) Encoder connector (b) Motor/Brake connector

\* Figures in [ ] represent the dimensions with brake.  
If you find two figures in [ ], left figure is for 200 V and right figure is for 400 V.

• MGME20□□1\*

[Unit: mm]

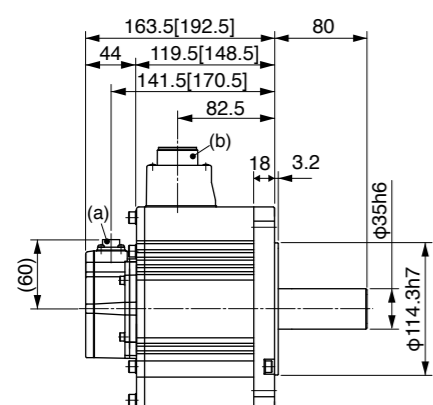

(a) Encoder connector  
(b) Motor/Brake connector

\* Figures in [ ] represent the dimensions with brake.

• MGME30□□1\*

[Unit: mm]

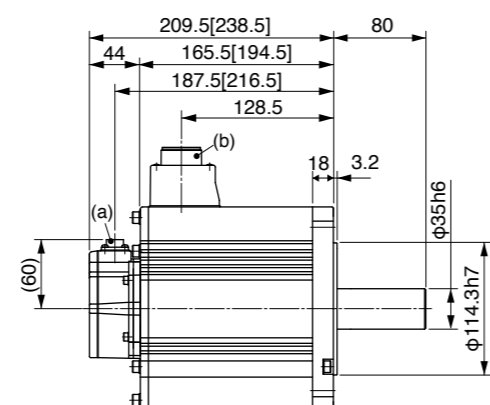

(a) Encoder connector  
(b) Motor/Brake connector

\* Figures in [ ] represent the dimensions with brake.

\* For motor specifications, refer to IP65 motor page.

• MHME10□□1\*

[Unit: mm]

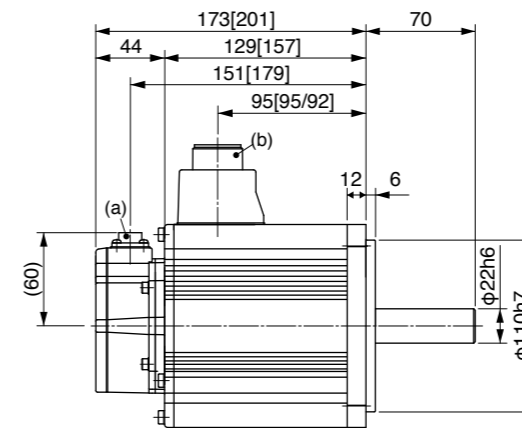

(a) Encoder connector (b) Motor/Brake connector

\* Figures in [ ] represent the dimensions with brake.  
If you find two figures in [ ], left figure is for 200 V and right figure is for 400 V.

• MHME15□□1\*

[Unit: mm]

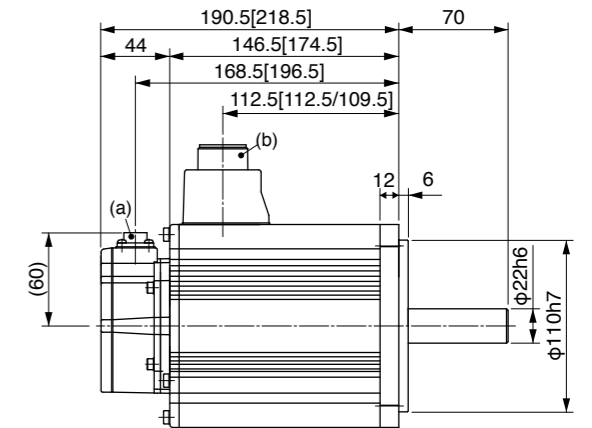

(a) Encoder connector (b) Motor/Brake connector

\* Figures in [ ] represent the dimensions with brake.  
If you find two figures in [ ], left figure is for 200 V and right figure is for 400 V.

• MHME20□□1\*

[Unit: mm]

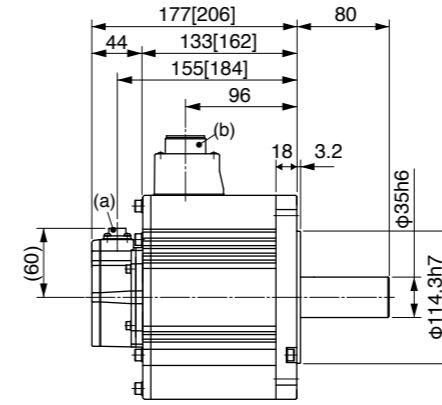

(a) Encoder connector  
(b) Motor/Brake connector

\* Figures in [ ] represent the dimensions with brake.

• MHME30□□1\*

[Unit: mm]

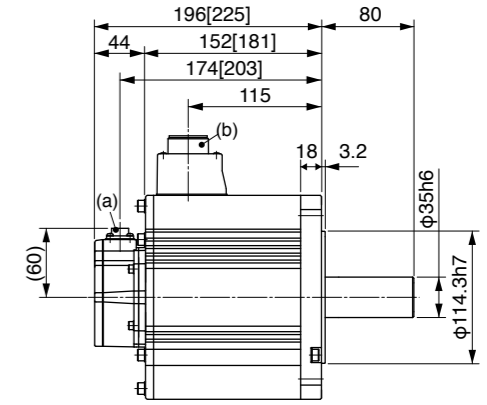

(a) Encoder connector  
(b) Motor/Brake connector

\* Figures in [ ] represent the dimensions with brake.

• MHME40□□1\*

[Unit: mm]

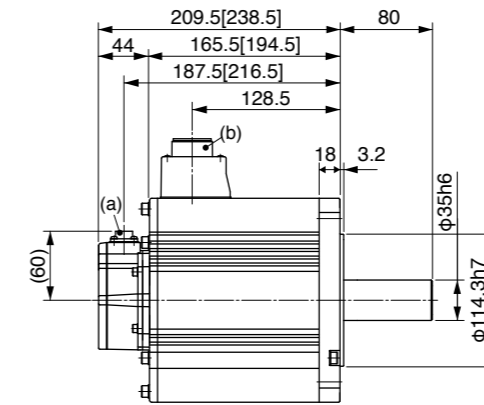

(a) Encoder connector  
(b) Motor/Brake connector

\* Figures in [ ] represent the dimensions with brake.

• MHME50□□1\*

[Unit: mm]

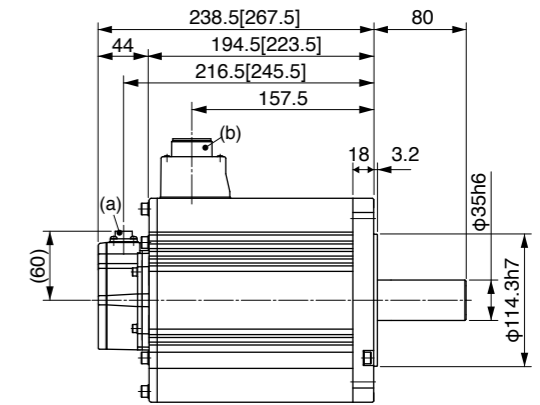

(a) Encoder connector  
(b) Motor/Brake connector

\* Figures in [ ] represent the dimensions with brake.

\* For motor specifications, refer to IP65 motor page.

Motor Types with Gear Reducer



Reduction ratio	Motor output (W)				Type of reducer
	100	200	400	750	
1/5	●	●	●	●	For high precision
1/9	●	●	●	●	
1/15	●	●	●	●	
1/25	●	●	●	●	

\* MHMD 100 W is not prepared.

Efficiency of the gear reducer show the following inclination in relation to output torque and rotational speed.

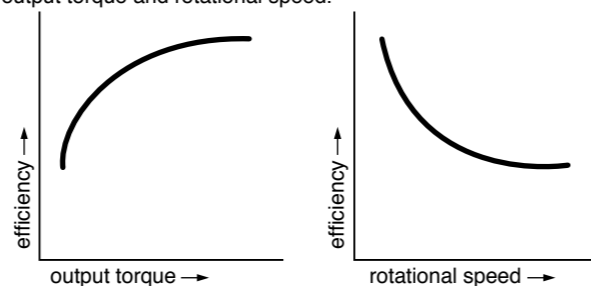

Specifications of Motor with Gear Reducer

Items	Specifications	
Gear reducer	Backlash	3 minutes or smaller (initial value) at output shaft of the reducer
	Composition of gear	Planetary gear
	Gear efficiency	65 % to 85 %
	Lubrication	Grease lubrication
	Rotational direction at output shaft	Same direction as the motor output shaft
	Mounting method	Flange mounting
	Permissible moment of inertia of the load (conversion to the motor shaft)	10 times or smaller than rotor moment of inertia of the motor
Environment	Protective structure	IP44 (at gear reducer)
	Ambient temperature	0 to 40 °C (free from condensation)
	Ambient humidity	85 %RH (free from condensation) or less
	Vibration resistance	49 m/s <sup>2</sup> or less (at motor frame)
	Impact resistance	98 m/s <sup>2</sup> or less

\* For combination of elements of model number, refer to Index.

Model Designation

M S M E 0 1 1 G 3 1 N

Symbol	Type
MSMD	Low inertia 100 W to 750 W
MSME	Low inertia 100 W to 750 W
MHMD	High inertia 200 W to 750 W

Motor rated output

Symbol	Specifications
01	100 W
02	200 W
04	400 W
08	750 W

Voltage specifications

Symbol	Rated output
1	100 V
2	200 V

Rotary encoder specifications

Symbol	Format	Pulse counts	Resolution	Wire
G	Incremental	20-bit	1,048,576	5
S	Absolute	17-bit	131,072	7

\* S: can be used in incremental.

Motor types with gear reducer

Symbol	Reduction ratio	Motor output (W)				Type of reducer
		100	200	400	750	
1N	1/5	●	●	●	●	For high precision
2N	1/9	●	●	●	●	
3N	1/15	●	●	●	●	
4N	1/25	●	●	●	●	

\* MHMD 100 W is not prepared.

Motor structure

Symbol	Shaft	Holding brake	
	Key way	without	with
3	●	●	
4	●		●

The Combination of the Driver and the Motor

Motor output	100 V		200 V	
	Part No. of motor with reducer	Single phase, 100 V	Part No. of motor with reducer	3-phase, 200 V
		Part No. of driver		Part No. of driver
100 W	MSME011□□□N MSMD011□□□N	MADHT1107 MADKT1107	MSME012□□□N MSMD012□□□N	MADHT1505 MADKT1505
		MADHT1107E MADKT1107E		MADHT1505E MADKT1505E
200 W	MSME021□□□N MSMD021□□□N MHMD021□□□N	MBDHT2110 MBDKT2110	MSME022□□□N MSMD022□□□N MHMD022□□□N	MADHT1507 MADKT1507
		MBDHT2110E MBDKT2110E		MADHT1507E MADKT1507E
400 W	MSME041□□□N MSMD041□□□N MHMD041□□□N	MCDHT3120 MCDKT3120	MSME042□□□N MSMD042□□□N MHMD042□□□N	MBDHT2510 MBDKT2510
		MCDHT3120E MCDKT3120E		MBDHT2510E MBDKT2510E
750 W	—	—	MSME082□□□N MSMD082□□□N MHMD082□□□N	MCDHT3520 MCDKT3520
				MCDHT3520E MCDKT3520E

\* Motor specifications enter to □□□ of the motor model number. Refer to "Model designation".

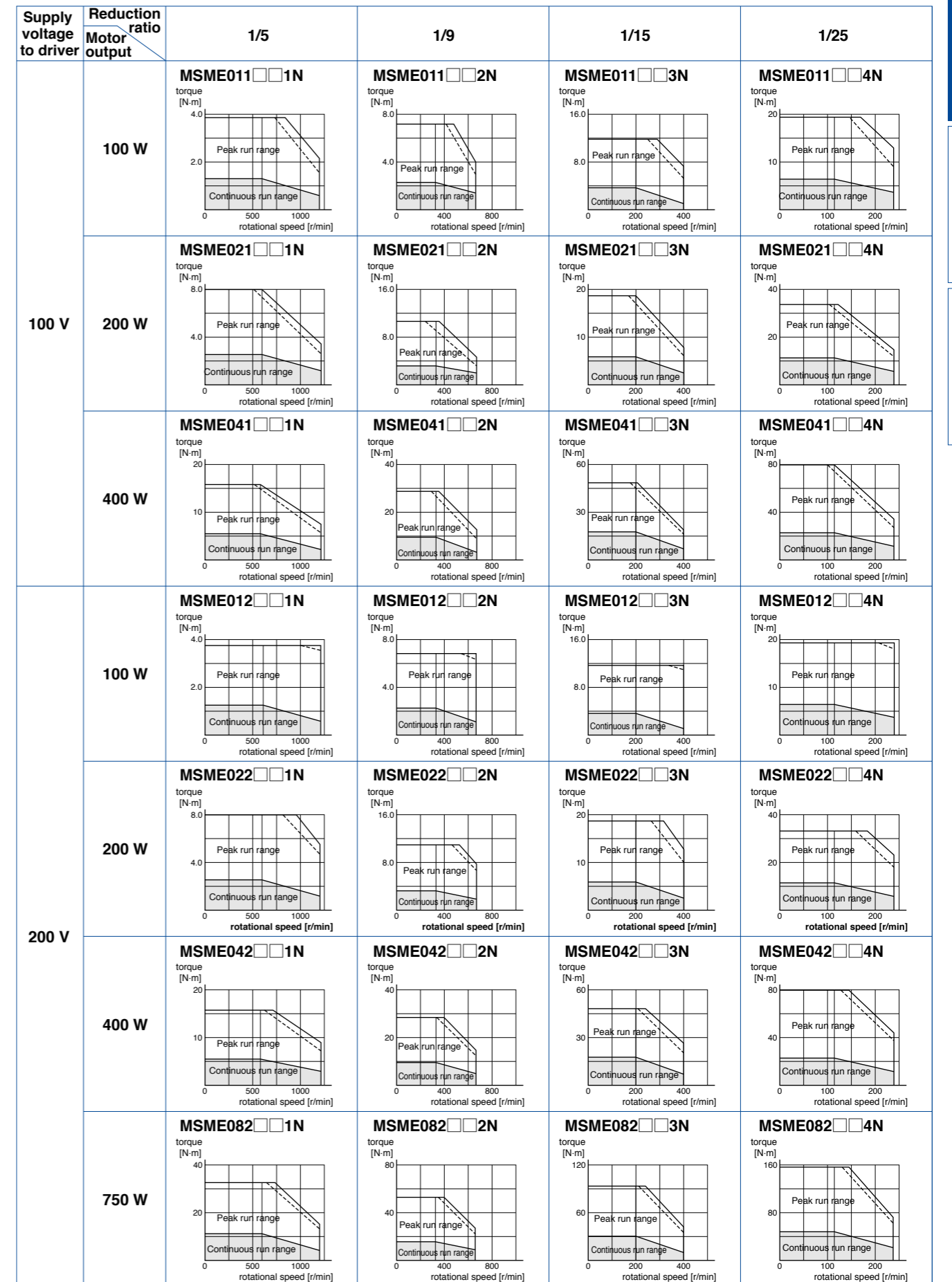

Table of Motor Specifications

Model	Motor Output (W)	Reduction ratio	Output (W)	Rated speed (r/min)	Max. speed (r/min)	Rated torque (N·m)	Peak max. torque (N·m)	Moment of inertia (motor + reducer/ converted to motor shaft)		Mass		Permissible radial load (N)	Permissible thrust load (N)
								w/o brake	w/ brake	w/o brake	w/ brake		
								J (×10 <sup>-4</sup> kg·m <sup>2</sup> )		(kg)			
<b>MSME01</b> □□□ 1N	100	1/5	75	600	1200	1.18	3.72	0.091	0.094	1.0	1.2	490	245
<b>MSME01</b> □□□ 2N		1/9	80	333	666	2.25	6.86	0.0853	0.0883	1.0	1.2	588	294
<b>MSME01</b> □□□ 3N		1/15	80	200	400	3.72	11.4	0.086	0.089	1.15	1.35	784	392
<b>MSME01</b> □□□ 4N		1/25	80	120	240	6.27	19.0	0.0885	0.0915	2.15	2.35	1670	833
<b>MSME02</b> □□□ 1N	200	1/5	170	600	1200	2.65	8.04	0.258	0.278	1.5	1.92	490	245
<b>MSME02</b> □□□ 2N		1/9	132	333	666	3.72	11.3	0.408	0.428	2.48	2.9	1180	588
<b>MSME02</b> □□□ 3N		1/15	132	200	400	6.27	18.8	0.44	0.46	2.88	3.3	1470	735
<b>MSME02</b> □□□ 4N		1/25	140	120	240	11.1	33.3	0.428	0.448	2.88	3.3	1670	833
<b>MSME04</b> □□□ 1N	400	1/5	340	600	1200	5.39	16.2	0.623	0.643	2.9	3.3	980	490
<b>MSME04</b> □□□ 2N		1/9	332	333	666	9.51	28.5	0.528	0.548	2.9	3.3	1180	588
<b>MSME04</b> □□□ 3N		1/15	332	200	400	15.8	47.5	0.56	0.58	3.3	3.7	1470	735
<b>MSME04</b> □□□ 4N		1/25	332	120	240	26.4	79.2	0.56	0.58	4.4	4.8	2060	1030
<b>MSME082</b> □□ 1N	750	1/5	672	600	1200	10.7	32.1	1.583	1.683	4.4	5.2	980	490
<b>MSME082</b> □□ 2N		1/9	635	333	666	18.2	54.7	1.52	1.62	5.7	6.5	1470	735
<b>MSME082</b> □□ 3N		1/15	635	200	400	30.4	91.2	1.57	1.67	6.1	6.9	1760	882
<b>MSME082</b> □□ 4N		1/25	635	120	240	50.7	152	1.52	1.62	6.1	6.9	2650	1320
<b>MSMD01</b> □□□ 1N	100	1/5	75	600	1000	1.18	3.72	0.091	0.094	1.02	1.23	490	245
<b>MSMD01</b> □□□ 2N		1/9	80	333	555	2.25	6.86	0.0853	0.0883	1.02	1.23	588	294
<b>MSMD01</b> □□□ 3N		1/15	80	200	333	3.72	11.4	0.086	0.089	1.17	1.38	784	392
<b>MSMD01</b> □□□ 4N		1/25	80	120	200	6.27	19.0	0.0885	0.0915	2.17	2.38	1670	833
<b>MSMD02</b> □□□ 1N	200	1/5	170	600	1000	2.65	8.04	0.258	0.278	1.54	2.02	490	245
<b>MSMD02</b> □□□ 2N		1/9	132	333	555	3.72	11.3	0.408	0.428	2.52	3	1180	588
<b>MSMD02</b> □□□ 3N		1/15	132	200	333	6.27	18.8	0.44	0.46	2.92	3.4	1470	735
<b>MSMD02</b> □□□ 4N		1/25	140	120	200	11.1	33.3	0.428	0.448	2.92	3.4	1670	833
<b>MSMD04</b> □□□ 1N	400	1/5	340	600	1000	5.39	16.2	0.623	0.643	2.9	3.4	980	490
<b>MSMD04</b> □□□ 2N		1/9	332	333	555	9.51	28.5	0.528	0.548	2.9	3.4	1180	588
<b>MSMD04</b> □□□ 3N		1/15	332	200	333	15.8	47.5	0.56	0.58	3.3	3.8	1470	735
<b>MSMD04</b> □□□ 4N		1/25	332	120	200	26.4	79.2	0.56	0.58	4.4	4.9	2060	1030
<b>MSMD082</b> □□ 1N	750	1/5	672	600	900	10.7	32.1	1.583	1.683	4.4	5.2	980	490
<b>MSMD082</b> □□ 2N		1/9	635	333	500	18.2	54.7	1.52	1.62	5.7	6.5	1470	735
<b>MSMD082</b> □□ 3N		1/15	635	200	300	30.4	91.2	1.57	1.67	6.1	6.9	1760	882
<b>MSMD082</b> □□ 4N		1/25	635	120	180	50.7	152	1.52	1.62	6.1	6.9	2650	1320
<b>MHMD02</b> □□□ 1N	200	1/5	170	600	1000	2.65	8.04	0.538	0.568	1.68	2.12	490	245
<b>MHMD02</b> □□□ 2N		1/9	132	333	555	3.72	11.3	0.688	0.718	2.66	3.1	1180	588
<b>MHMD02</b> □□□ 3N		1/15	132	200	333	6.27	18.8	0.72	0.75	3.06	3.5	1470	735
<b>MHMD02</b> □□□ 4N		1/25	140	120	200	11.1	33.3	0.708	0.738	3.06	3.5	1670	833
<b>MHMD04</b> □□□ 1N	400	1/5	340	600	1000	5.39	16.2	1.033	1.063	3.1	3.5	980	490
<b>MHMD04</b> □□□ 2N		1/9	332	333	555	9.51	28.5	0.938	0.968	3.1	3.5	1180	588
<b>MHMD04</b> □□□ 3N		1/15	332	200	333	15.8	47.5	0.97	1.0	3.5	3.9	1470	735
<b>MHMD04</b> □□□ 4N		1/25	332	120	200	26.4	79.2	0.97	1.0	4.6	5.0	2060	1030
<b>MHMD082</b> □□ 1N	750	1/5	672	600	900	10.7	32.1	2.223	2.323	4.6	5.4	980	490
<b>MHMD082</b> □□ 2N		1/9	635	333	500	18.2	54.7	2.16	2.26	5.9	6.7	1470	735
<b>MHMD082</b> □□ 3N		1/15	635	200	300	30.4	91.2	2.21	2.31	6.3	7.1	1760	882
<b>MHMD082</b> □□ 4N		1/25	635	120	180	50.7	152	2.16	2.26	6.3	7.1	2650	1320

\* Motor specifications enter to □□□ of the motor model number. Refer to "Model designation".

MSME series (100 W to 750 W)



Dotted line represents the torque at 10 % less supply voltage.

MSMD series (100 W to 750 W)

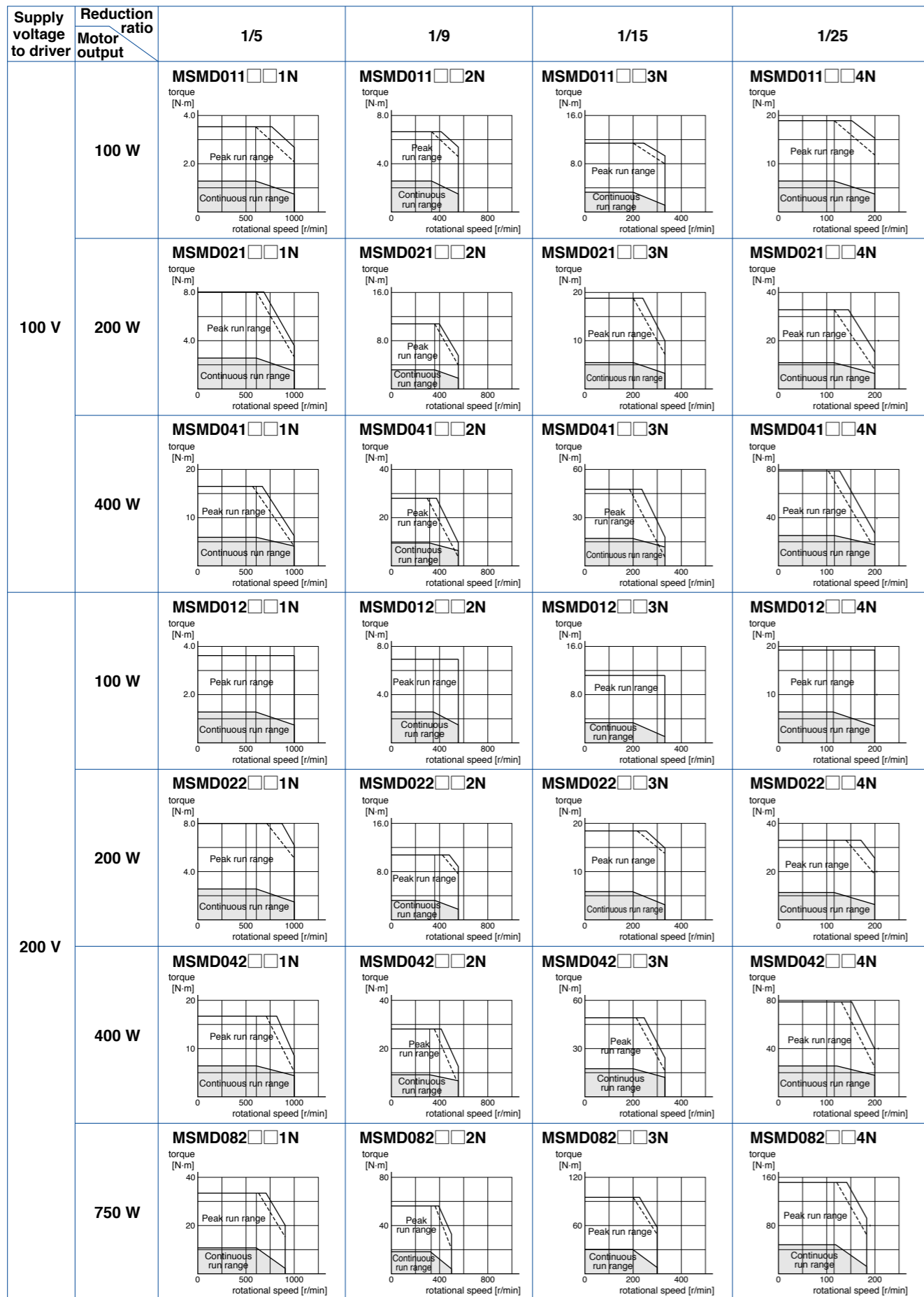

Dotted line represents the torque at 10 % less supply voltage.

MHMD series (200 W to 750 W)

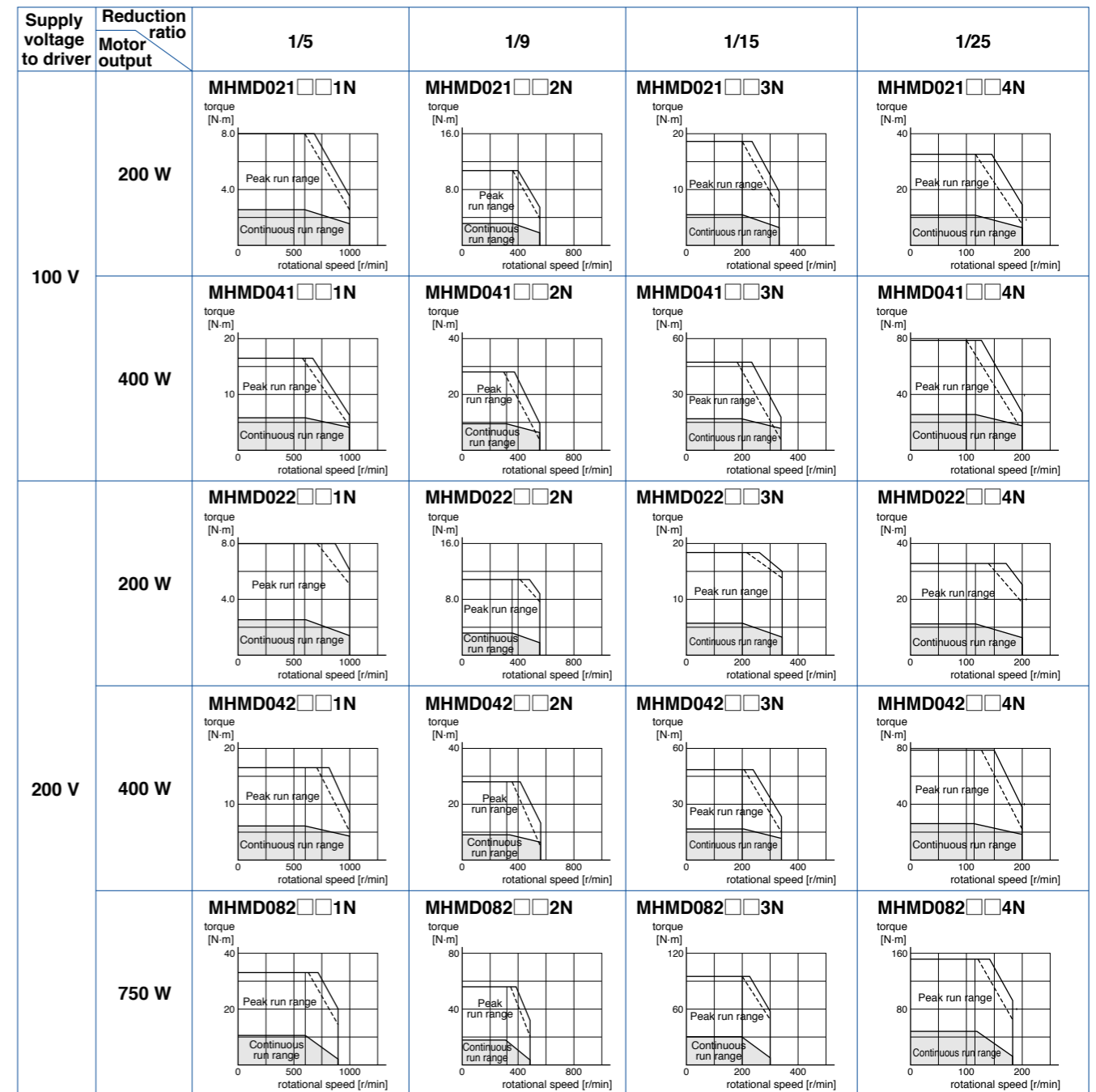

Dotted line represents the torque at 10 % less supply voltage.

MSME series

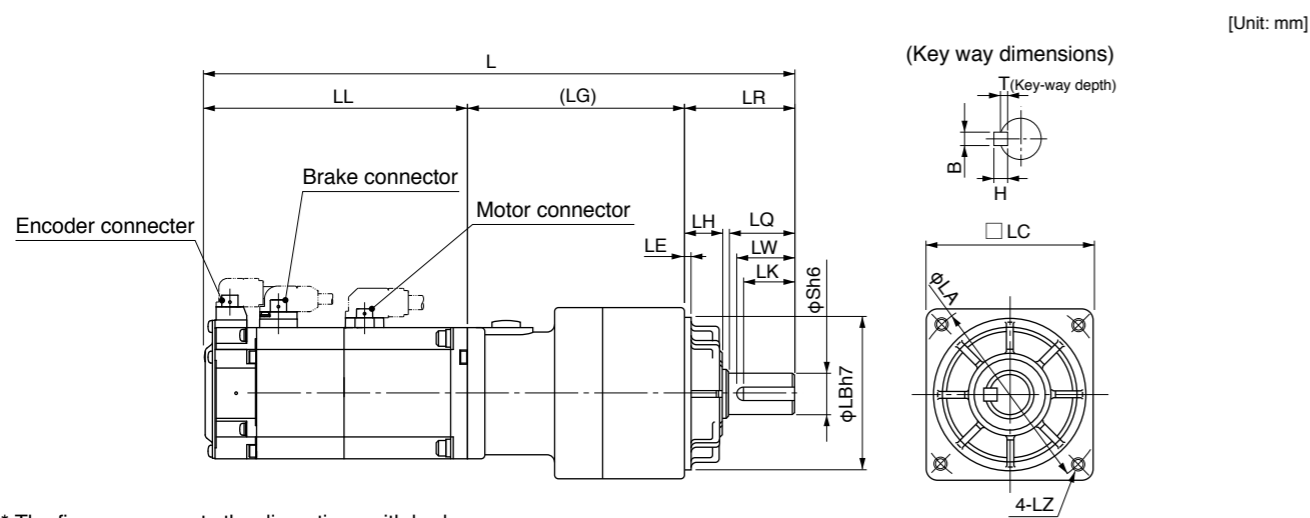

\* The figure represents the dimentions with brake.

Model	Motor output (W)	Reduction ratio	L	LL	LR	LQ	LC	LB	LA	S	LH	LZ	LW	(LG)	LE	Key way BxHxLK	T
MSME01□□□1N	100	1/5	191.5	92	32	20	52	50	60	12	10	M5 Depth 12	18	67.5	4x4x16	2.5	
			221.5	122													
MSME01□□□2N	100	1/9	191.5	92	32	20	52	50	60	12	10	M5 Depth 12	18	67.5	4x4x16	2.5	
			221.5	122													
MSME01□□□3N	100	1/15	202	92	32	20	52	50	60	12	10	M5 Depth 12	18	78	4x4x16	2.5	
			232	122													
MSME01□□□4N	100	1/25	234	92	50	30	78	70	90	19	17	M6 Depth 20	26	92	6x6x22	3.5	
			264	122													
MSME02□□□1N	200	1/5	184	79.5	32	20	52	50	60	12	10	M5 Depth 12	18	72.5	4x4x16	2.5	
			220.5	116													
MSME02□□□2N	200	1/9	219	79.5	32	20	52	50	60	12	10	M5 Depth 12	18	89.5	3	4x4x16	2.5
			255.5	116													
MSME02□□□3N	200	1/15	229.5	79.5	32	20	52	50	60	12	10	M5 Depth 12	18	100	3	4x4x16	2.5
			266	116													
MSME02□□□4N	200	1/25	229.5	79.5	50	30	78	70	90	19	17	M6 Depth 20	26	100	6x6x22	3.5	
			266	116													
MSME04□□□1N	400	1/5	238.5	99	50	30	78	70	90	19	17	M6 Depth 20	26	89.5	6x6x22	3.5	
			275	135.5													
MSME04□□□2N	400	1/9	238.5	99	50	30	78	70	90	19	17	M6 Depth 20	26	89.5	6x6x22	3.5	
			275	135.5													
MSME04□□□3N	400	1/15	249	99	50	30	78	70	90	19	17	M6 Depth 20	26	100	6x6x22	3.5	
			285.5	135.5													
MSME04□□□4N	400	1/25	264	99	61	40	98	90	115	24	18	M8 Depth 20	35	104	5	8x7x30	4
			300.5	135.5													
MSME082□□1N	750	1/5	255.7	112.2	50	30	78	70	90	19	17	M6 Depth 20	26	93.5	3	6x6x22	3.5
			291.7	148.2													
MSME082□□2N	750	1/9	270.7	112.2	50	30	78	70	90	19	17	M6 Depth 20	26	97.5	3	6x6x22	3.5
			306.7	148.2													
MSME082□□3N	750	1/15	283.2	112.2	61	40	98	90	115	24	18	M8 Depth 20	35	110	5	8x7x30	4
			319.2	148.2													
MSME082□□4N	750	1/25	283.2	112.2	61	40	98	90	115	24	18	M8 Depth 20	35	110	5	8x7x30	4
			319.2	148.2													

Upper column: without brake   
 Lower column: with brake

MSMD series

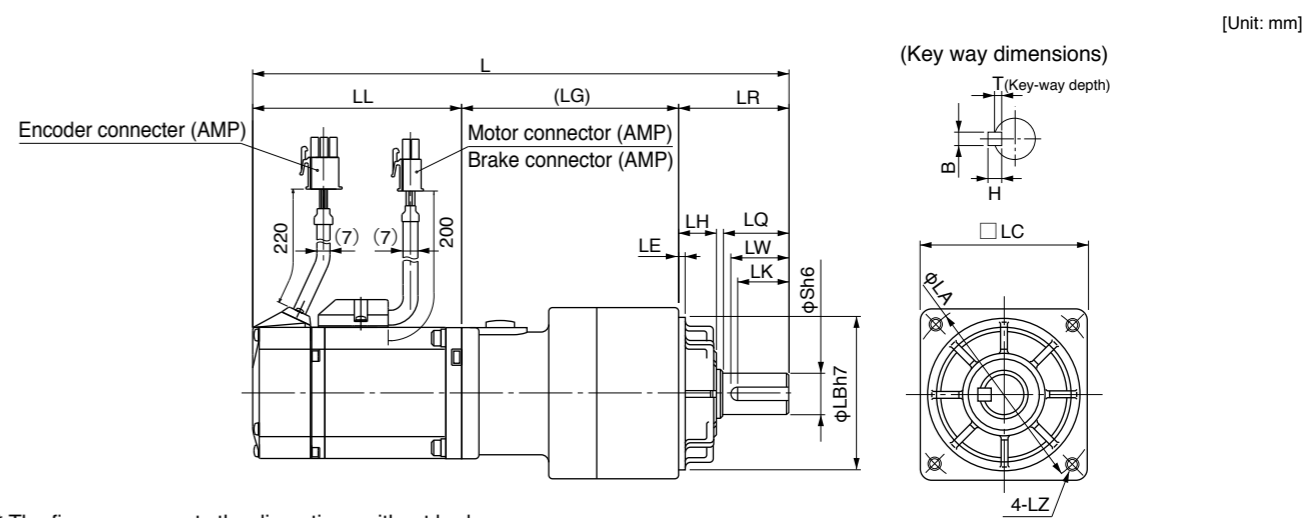

\* The figure represents the dimentions without brake.

Model	Motor output (W)	Reduction ratio	L	LL	LR	LQ	LC	LB	LA	S	LH	LZ	LW	(LG)	LE	Key way BxHxLK	T
MSMD01□□□1N	100	1/5	191.5	92	32	20	52	50	60	12	10	M5 Depth 12	18	67.5	4x4x16	2.5	
			221.5	122													
MSMD01□□□2N	100	1/9	191.5	92	32	20	52	50	60	12	10	M5 Depth 12	18	67.5	4x4x16	2.5	
			221.5	122													
MSMD01□□□3N	100	1/15	202	92	32	20	52	50	60	12	10	M5 Depth 12	18	78	4x4x16	2.5	
			232	122													
MSMD01□□□4N	100	1/25	234	92	50	30	78	70	90	19	17	M6 Depth 20	26	92	6x6x22	3.5	
			264	122													
MSMD02□□□1N	200	1/5	184	79.5	32	20	52	50	60	12	10	M5 Depth 12	18	72.5	4x4x16	2.5	
			220.5	116													
MSMD02□□□2N	200	1/9	219	79.5	32	20	52	50	60	12	10	M5 Depth 12	18	89.5	3	4x4x16	2.5
			255.5	116													
MSMD02□□□3N	200	1/15	229.5	79.5	32	20	52	50	60	12	10	M5 Depth 12	18	100	3	4x4x16	2.5
			266	116													
MSMD02□□□4N	200	1/25	229.5	79.5	50	30	78	70	90	19	17	M6 Depth 20	26	100	6x6x22	3.5	
			266	116													
MSMD04□□□1N	400	1/5	238.5	99	50	30	78	70	90	19	17	M6 Depth 20	26	89.5	6x6x22	3.5	
			275	135.5													
MSMD04□□□2N	400	1/9	238.5	99	50	30	78	70	90	19	17	M6 Depth 20	26	89.5	6x6x22	3.5	
			275	135.5													
MSMD04□□□3N	400	1/15	249	99	50	30	78	70	90	19	17	M6 Depth 20	26	100	6x6x22	3.5	
			285.5	135.5													
MSMD04□□□4N	400	1/25	264	99	61	40	98	90	115	24	18	M8 Depth 20	35	104	5	8x7x30	4
			300.5	135.5													
MSMD082□□1N	750	1/5	255.7	112.2	50	30	78	70	90	19	17	M6 Depth 20	26	93.5	3	6x6x22	3.5
			292.7	149.2													
MSMD082□□2N	750	1/9	270.7	112.2	50	30	78	70	90	19	17	M6 Depth 20	26	97.5	3	6x6x22	3.5
			307.7	149.2													
MSMD082□□3N	750	1/15	283.2	112.2	61	40	98	90	115	24	18	M8 Depth 20	35	110	5	8x7x30	4
			320.2	149.2													
MSMD082□□4N	750	1/25	283.2	112.2	61	40	98	90	115	24	18	M8 Depth 20	35	110	5	8x7x30	4
			320.2	149.2													

Upper column: without brake   
 Lower column: with brake









Features

- Line-up IP65 motor: 200 W to 5.0 kW
- Max speed: 5000 r/min (MSMJ, MHMJ)
- Low inertia (MSME) to High inertia (MHME).
- 20-bit incremental encoder (1,048,576 pulse)
- 17-bit absolute encoder (131,072 pulse).

[Please note]

Motors displayed at P.151 to P.181 are Special Order Product. Please contact us for more information.

Motor Lineup

Small capacity	 <p><b>MSMJ</b> Low inertia</p> <p>Max. speed : 5000 r/min : 4500 r/min (750 W) Rated speed: 3000 r/min Rated output: 200 W to 750 W Enclosure : IP65</p>	 <p><b>MHMJ</b> High inertia</p> <p>Max. speed : 5000 r/min : 4500 r/min (750 W) Rated speed: 3000 r/min Rated output: 200 W to 750 W Enclosure : IP65</p>
	 <p><b>MSME</b> Low inertia</p> <p>Max. speed : 5000 r/min : 4500 r/min (from 4.0 kW) Rated speed: 3000 r/min Rated output: 1.0 kW to 5.0 kW Enclosure : IP65</p>	 <p><b>MDME</b> Middle inertia</p> <p>Max. speed : 3000 r/min Rated speed : 2000 r/min Rated output: IP65 1.0 kW to 5.0 kW Enclosure : IP65</p>
Middle capacity	 <p><b>MGME</b> (Low speed/ High torque type) High inertia</p> <p>Max. speed : 2000 r/min Rated speed : 1000 r/min Rated output: IP65 0.9 kW to 3.0 kW Enclosure : IP65</p>	 <p><b>MHME</b> High inertia</p> <p>Max. speed : 3000 r/min Rated speed : 2000 r/min Rated output: IP65 1.0 kW to 5.0 kW Enclosure : IP65</p>

Special Order Product Motor Contents

**MSMJ (200 V)**  
200 W to 750 W ..... P.155

**MSME (200 V)**  
1.0 kW to 5.0 kW ..... P.158

**MDME (200V)**  
1.0 kW to 5.0 kW ..... P.164

**MGME (200 V)**  
0.9 kW to 5.0 kW ..... P.170

**MHMJ (200 V)**  
200 W to 750 W ..... P.173

**MHME (200V)**  
1.0 kW to 5.0 kW ..... P.176

<Cautions> Please avoid the motor, or equipment containing the motor to be distributed to Japan, or other regions through Japan.

Model Designation

\* For combination of elements of model number, refer to Index.

Servo Motor

M S M E 5 0 2 G C S M \*

Symbol	Type
MSMJ	Low inertia (200 W to 750 W)
MSME	Low inertia (1.0 kW to 5.0 kW)
MDME	Middle inertia (1.0 kW to 5.0 kW)
MGME	High inertia (0.9 kW to 5.0 kW)
MHMJ	High inertia (200 W to 750 W)
MHME	High inertia (1.0 kW to 5.0 kW)

Motor rated output

Symbol	Rated output
02	200 W
04	400 W
08	750 W
09	0.9 kW
10	1.0 kW
15	1.5 kW
20	2.0 kW
30	3.0 kW
40	4.0 kW
50	5.0 kW

Voltage specifications  
2: 200 V

Rotary encoder specifications

Symbol	Format	Pulse counts	Resolution	Wires
G	Incremental	20-bit	1,048,576	5
S	Absolute	17-bit	131,072	7

\* S: can be used in incremental.

<Cautions>

Please avoid the motor, or equipment containing the motor to be distributed to Japan, or other regions through Japan.

Special specifications

MSMJ, MHMJ  
Special specifications

MSME, MDME, MGME, MHME  
M: Special Order Product

Motor specifications  
MSMJ, MHMJ

Symbol	Shaft		Holding brake		Oil seal	
	Round	Key-way, center tap	without	with	without	with
A	●		●		●	
B	●			●	●	
C	●		●			●
D	●			●		●
S		●	●		●	
T		●		●	●	
U		●	●			●
V		●		●		●

MSME, MDME, MGME, MHME

Symbol	Shaft		Holding brake		Oil seal	
	Round	Key-way	without	with	without	with
C	●		●			●
D	●			●		●
G		●	●			●
H		●		●		●

Design order

Symbol	Specifications
C	IP65 motor (MSME, MDME, MGME, MHME)
1	IP65 motor (MSMJ, MHMJ)

Servo Driver

Speed, Position, Torque, Full-closed type

M A D K T 1 5 0 5 \* \* \* Special specifications

Position control type

M A D K T 1 5 0 5 E \* \* Special specifications

Frame symbol \*

Symbol	Frame
MAD	Frame A
MBD	Frame B
MCD	Frame C
MDD	Frame D
MED	Frame E
MFD	Frame F

Series

Symbol	Velocity, Position, Torque, Full-Closed type	Position control type
K	A5 II series	A5 II E series

Supply voltage specifications

Symbol	Specifications
3	3-phase, 200 V
5	Single/3-phase, 200 V

Power device Max. current rating

Symbol	Current rating
T1	10 A
T2	15 A
T3	30 A
T5	50 A
T7	75 A
TA	100 A
TB	150 A

Current detector current rating

Symbol	Specifications
07	7.5 A
10	10 A
20	20 A
30	30 A
40	40 A
64	64 A
90	90 A
A2	120 A

Motor series	Motor				Driver			Power capacity (at rated load) (kVA)	Optional parts																			
	Power supply	Output (W)	Part No. (Note) 1	Rating/Spec. (page)	A5II series Part No. (Speed, Position, Torque, Full-Closed type)	A5IIE series Part No. (Position control type) (Note) 2	Frame		Encoder Cable		Motor Cable		Brake Cable (Note) 3	External Regenerative Resistor	Reactor (Single phase / 3-phase)	Noise Filter (Single phase / 3-phase)												
									20-bit Incremental (Note) 3	17-bit Absolute (Note) 2,3	without Brake (Note) 3	with Brake (Note) 3																
Low inertia	MSMJ (Leadwire type) 3000 r/min	200	MSMJ022 □ 1 *	155	MADKT1507	MADKT1507E	A-frame	Approx. 0.5	MFECA 0**0EAM	MFECA 0**0EAE (Note) 4	MFMCA 0**0EED	-	MFMCB 0**0GET	DV0P4283	DV0P227	DV0P4170												
		400	MSMJ042 □ 1 *	156	MBDKT2510	MBDKT2510E	B-frame	Approx. 0.9							DV0P220		DV0PM20042											
		750	MSMJ082 □ 1 *	157	MCDKT3520	MCDKT3520E	C-frame	Approx. 1.3							DV0P228													
	1000	MSME102 □ C * M	158	MDDKT5540	MDDKT5540E	D-frame	Approx. 1.8	DV0P220																				
	1500	MSME152 □ C * M	159	MDDKT5540	MDDKT5540E		Approx. 2.3	DV0P222							DV0P4220													
	MSME 3000 r/min	3-phase 200 V	2000	MSME202 □ C * M	160	MEDKT7364	MEDKT7364E	E-frame							Approx. 3.3		MFMCB 0**0GET	MFMCB 0**0GET	-	-	-	-	DV0P228	DV0PM20042				
			3000	MSME302 □ C * M	161	MFDKTA390	MFDKTA390E	F-frame							Approx. 4.5								DV0P222					
			4000	MSME402 □ C * M	162	MFDKTB3A2	MFDKTB3A2E								Approx. 6								DV0P220					
		5000	MSME502 □ C * M	163	MFDKTB3A2	MFDKTB3A2E	F-frame	Approx. 7.5							DV0P222								DV0P4220					
		3-phase 200 V	2000	MSME202 □ C * M	160	MEDKT7364	MEDKT7364E	E-frame							Approx. 3.3								MFMCB 0**0GET		MFMCB 0**0GET	-	-	-
3000			MSME302 □ C * M	161	MFDKTA390	MFDKTA390E	F-frame	Approx. 4.5	DV0P222																			
4000			MSME402 □ C * M	162	MFDKTB3A2	MFDKTB3A2E		Approx. 6	DV0P220																			
5000	MSME502 □ C * M		163	MFDKTB3A2	MFDKTB3A2E	F-frame	Approx. 7.5	DV0P222	DV0P4220																			
Middle inertia	MDME 2000 r/min	Single phase/ 3-phase 200 V	1000	MDME102 □ C * M	164	MDDKT3530	MDDKT3530E	D-frame	MFECA 0**0ESD	MFECA 0**0ESE	MFMCB 0**0GET	-	-	-	-	-	DV0P228	DV0P4220										
			1500	MDME152 □ C * M	165	MDDKT5540	MDDKT5540E										Approx. 2.3		DV0P222									
		3-phase 200 V	2000	MDME202 □ C * M	166	MEDKT7364	MEDKT7364E	E-frame									Approx. 3.3		MFMCB 0**0GET	MFMCB 0**0GET	-	-	-	-	DV0P222	DV0P4220		
			3000	MDME302 □ C * M	167	MFDKTA390	MFDKTA390E	F-frame									Approx. 4.5								DV0P220			
			4000	MDME402 □ C * M	168	MFDKTB3A2	MFDKTB3A2E										Approx. 6								DV0P222			
	5000	MDME502 □ C * M	169	MFDKTB3A2	MFDKTB3A2E	F-frame	Approx. 7.5	DV0P222									DV0P4220											
	MGME (Low speed/ High torque type) 1000 r/min	Single phase/ 3-phase 200 V	900	MGME092 □ C * M	170	MDDKT5540	MDDKT5540E	D-frame									Approx. 1.8		MFECA 0**0ESD	MFECA 0**0ESE	MFMCB 0**0GET	-	-	-	-	-	DV0P228	DV0P4220
			2000	MGME202 □ C * M	171	MFDKTA390	MFDKTA390E	F-frame									Approx. 3.8										DV0P222	
		3-phase 200 V	3000	MGME302 □ C * M	172	MFDKTB3A2	MFDKTB3A2E										Approx. 4.5										DV0P220	
			3-phase 200 V	200	MHMJ022 □ 1 *	173	MADKT1507	MADKT1507E									A-frame										Approx. 0.5	
400				MHMJ042 □ 1 *	174	MBDKT2510	MBDKT2510E	B-frame	Approx. 0.9	DV0P220																		
High inertia	MHME 2000 r/min	Single phase/ 3-phase 200 V	750	MHMJ082 □ 1 *	175	MCDKT3520	MCDKT3520E	C-frame	Approx. 1.3	MFECA 0**0ESD	MFECA 0**0ESE	MFMCB 0**0GET	-	-	-	-	DV0P228	DV0P4220										
			1000	MHME102 □ C * M	176	MDDKT3530	MDDKT3530E	D-frame	Approx. 1.8								DV0P222											
		1500	MHME152 □ C * M	177	MDDKT5540	MDDKT5540E	Approx. 2.3		DV0P220																			
		3-phase 200 V	2000	MHME202 □ C * M	178	MEDKT7364	MEDKT7364E	E-frame	Approx. 3.3								MFECB 0**0GET		MFECB 0**0GET	-	-	-	-	DV0P222	DV0P4220			
			3000	MHME302 □ C * M	179	MFDKTA390	MFDKTA390E	F-frame	Approx. 4.5															DV0P220				
	4000		MHME402 □ C * M	180	MFDKTB3A2	MFDKTB3A2E	Approx. 6		DV0P222																			
	5000	MHME502 □ C * M	181	MFDKTB3A2	MFDKTB3A2E	F-frame	Approx. 7.5	DV0P222	DV0P4220																			

Note) 1 Rotary encoder specifications: □ Motor specification: \* (refer to P.152)  
 Note) 2 Because A5IIE series drivers (dedicated for position control) do not support the 17-bit absolute specification, only 20-bit incremental type can be used in combination.  
 Note) 3 Cable length: \*\* (03: 3 m, 05: 5 m, 10: 10 m, 20: 20 m), (Example. 3 m: MFECA0030EAM)  
 Note) 4 When you use a 17-bit absolute encoder as an incremental encoder, please use the encoder cable MFECA0\*\*0EAD.  
 Note) 5 Other combinations exist, and refer to P.210 for details.  
 Note) 6 Reactor should be prepared by the user.

<Cautions> Please avoid the motor, or equipment containing the motor to be distributed to Japan, or other regions through Japan.

Options			Page
Title	Part No.		
Interface Cable	DV0P4360		197
	DV0P4120		
Interface Conversion Cable	DV0P4121		
	DV0P4130		
	DV0P4131		
	DV0P4132		
Connector Kit for Power Supply Input Connection	A to D-frame Single row type	DV0PM20032	200
	D-frame Double row type	DV0PM20033	
Connector Kit for Motor Connection	E-frame	DV0PM20044	201
	A to D-frame	DV0PM20034	
Connector Kit for Regenerative Resistor	E-frame	DV0PM20046	201
	E-frame	DV0PM20045	
Connector Kit for Motor/Encoder Connection		DV0P4290	202
		DV0P4310	204
		DV0P4320	205
		DV0P4330	205
		DV0P4340	202
		DV0P4380	202
Connector Kit	RS485, RS232	DV0PM20024	198
	Safety	DV0PM20025	
	Interface	DV0P4350	
	External Scale	DV0PM20026	
	Encoder	DV0PM20010	
	Analog Monitor Signal	DV0PM20031	199
Battery For Absolute Encoder		DV0P2990	207
Battery Box		DV0P4430	207
Mounting Bracket	A-frame	DV0PM20027	208
	B-frame	DV0PM20028	
	C-frame	DV0PM20029	
	D-frame	DV0PM20030	
Encoder Cable	without Battery Box	MFECA0**0EAD	188
		MFECA0**0EAM	
	with Battery Box	MFECA0**0EAD	
		MFECA0**0EAE	188
		MFECA0**0ESE	190
Motor Cable	without Brake	MFMCB0**0EED	191
		MFMCB0**2ECD	192
	with Brake	MFMCB0**2ECD	193
		MFMCB0**3ECT	194
		MFMCB0**2FCD	195
Brake Cable		MFMCB0**0GET	196
External Regenerative Resistor	A-frame	DV0P4283	210
	B-frame		
	C-frame	DV0P4284	
	D-frame		
	E-frame		
	F-frame	DV0P4285	
Reactor	DV0P220, DV0P221, DV0P222, DV0P223, DV0P224, DV0P225, DV0P227, DV0P228, DV0PM20047		209
	DV0P4170, DV0PM20042, DV0P4220, DV0PM20043		250
Noise Filter	DV0P3410		251
	Single phase		DV0P4190
Surge Absorber	3-phase		DV0P1450
Noise Filter for Signal Lines			DV0P1460

<Cautions> Please avoid the motor, or equipment containing the motor to be distributed to Japan, or other regions through Japan.

\* Please contact us for more information.

Specifications

		AC200 V	
Motor model *1	IP65	MSMJ022G1□	MSMJ022S1□
	IP67	-	-
Applicable driver *2	Model No.	A5I series A5IE series	MADKT1507 MADKT1507E
	Frame symbol	A-frame	
Power supply capacity (kVA)	0.5		
Rated output (W)	200		
Rated torque (N·m)	0.64		
Momentary Max. peak torque (N·m)	1.91		
Rated current (A(rms))	1.6		
Max. current (A(o-p))	6.9		
Regenerative brake frequency (times/min) Note1	Without option	No limit	Note2
	DV0P4283	No limit	Note2
Rated rotational speed (r/min)	3000		
Max. rotational speed (r/min)	5000		
Moment of inertia of rotor (×10 <sup>-4</sup> kg·m <sup>2</sup> )	Without brake	0.14	
	With brake	0.16	
Recommended moment of inertia ratio of the load and the rotor Note3	30 times or less		
Rotary encoder specifications Note5	20-bit Incremental	17-bit Absolute	
	Resolution per single turn	1,048,576	131,072

• Brake specifications (For details, refer to P.183)

(This brake will be released when it is energized.)  
(Do not use this for braking the motor in motion.)

Static friction torque (N·m)	1.27 or more
Engaging time (ms)	50 or less
Releasing time (ms) Note4	15 or less
Exciting current (DC) (A)	0.36
Releasing voltage (DC) (V)	1 or more
Exciting voltage (DC) (V)	24±1.2

• Permissible load (For details, refer to P.183)

During assembly	Radial load P-direction (N)	392
	Thrust load A-direction (N)	147
	Thrust load B-direction (N)	196
During operation	Radial load P-direction (N)	245
	Thrust load A, B-direction (N)	98

• For details of Note 1 to Note 5, refer to P.182, 183.

• Dimensions of Driver, refer to P.42.

\*1 Motor specifications: □

\*2 The product that the end of driver model designation has "E" is "Position control type".  
Detail of model designation, refer to P.152.

Torque characteristics (at AC200 V of power voltage <Dotted line represents the torque at 10% less supply voltage.>)

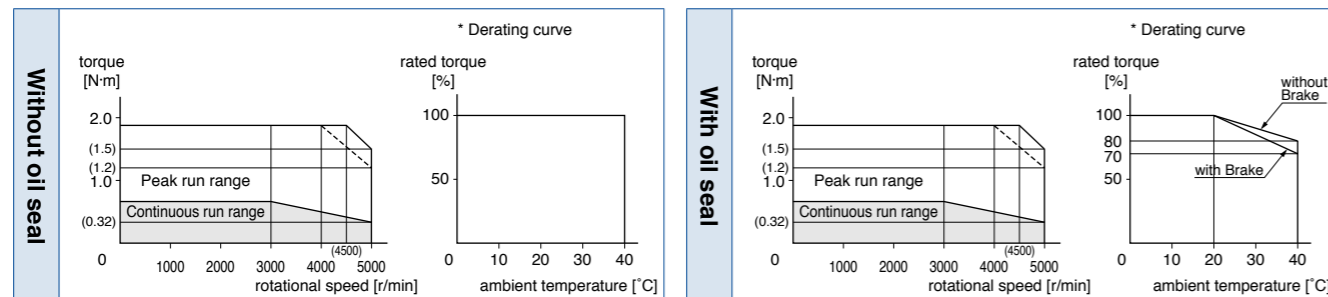

Dimensions

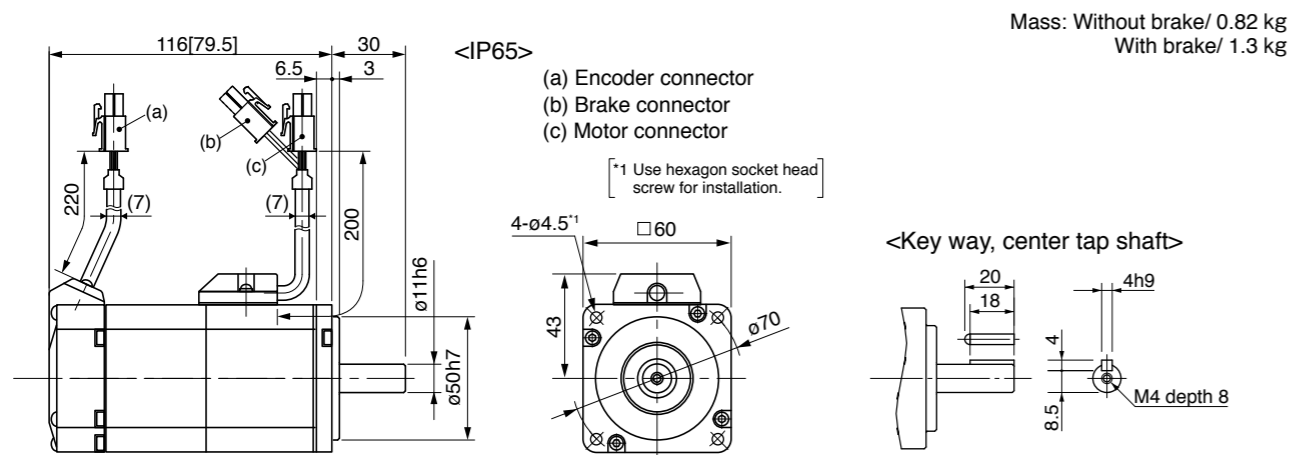

\* Figures in [ ] represent the dimensions without brake.

[Unit: mm]

<Cautions> Reduce the moment of inertia ratio if high speed response operation is required. Dimensions are subject to change without notice. Contact us or a dealer for the latest information. Read the Instruction Manual carefully and understand all precautions and remarks before using the products. Please avoid the motor, or equipment containing the motor to be distributed to Japan, or other regions through Japan.

\* Please contact us for more information.

Specifications

		AC200 V	
Motor model *1	IP65	MSMJ042G1□	MSMJ042S1□
	IP67	-	-
Applicable driver *2	Model No.	A5I series A5IE series	MBDKT2510 MBDKT2510E
	Frame symbol	B-frame	
Power supply capacity (kVA)	0.9		
Rated output (W)	400		
Rated torque (N·m)	1.3		
Momentary Max. peak torque (N·m)	3.8		
Rated current (A(rms))	2.6		
Max. current (A(o-p))	11.0		
Regenerative brake frequency (times/min) Note1	Without option	No limit	Note2
	DV0P4283	No limit	Note2
Rated rotational speed (r/min)	3000		
Max. rotational speed (r/min)	5000		
Moment of inertia of rotor (×10 <sup>-4</sup> kg·m <sup>2</sup> )	Without brake	0.26	
	With brake	0.28	
Recommended moment of inertia ratio of the load and the rotor Note3	30 times or less		
Rotary encoder specifications Note5	20-bit Incremental	17-bit Absolute	
	Resolution per single turn	1,048,576	131,072

• Brake specifications (For details, refer to P.183)

(This brake will be released when it is energized.)  
(Do not use this for braking the motor in motion.)

Static friction torque (N·m)	1.27 or more
Engaging time (ms)	50 or less
Releasing time (ms) Note4	15 or less
Exciting current (DC) (A)	0.36
Releasing voltage (DC) (V)	1 or more
Exciting voltage (DC) (V)	24±1.2

• Permissible load (For details, refer to P.183)

During assembly	Radial load P-direction (N)	392
	Thrust load A-direction (N)	147
	Thrust load B-direction (N)	196
During operation	Radial load P-direction (N)	245
	Thrust load A, B-direction (N)	98

• For details of Note 1 to Note 5, refer to P.182, 183.

• Dimensions of Driver, refer to P.42.

\*1 Motor specifications: □

\*2 The product that the end of driver model designation has "E" is "Position control type".  
Detail of model designation, refer to P.152.

Torque characteristics (at AC200 V of power voltage <Dotted line represents the torque at 10% less supply voltage.>)

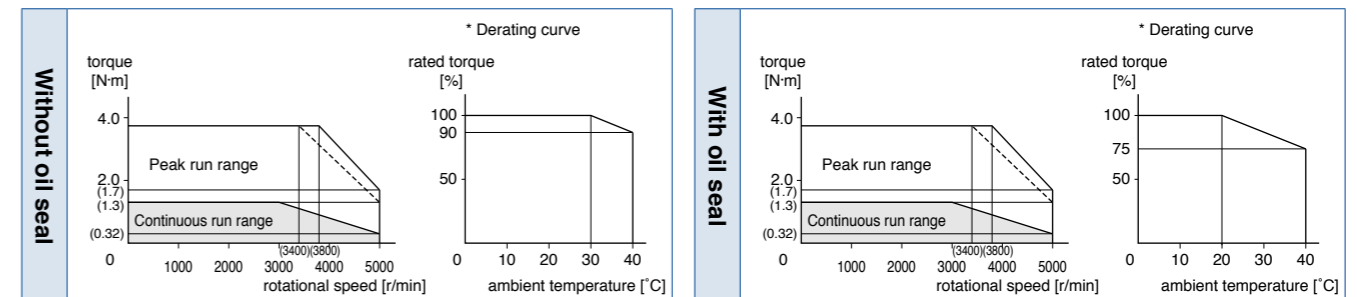

Dimensions

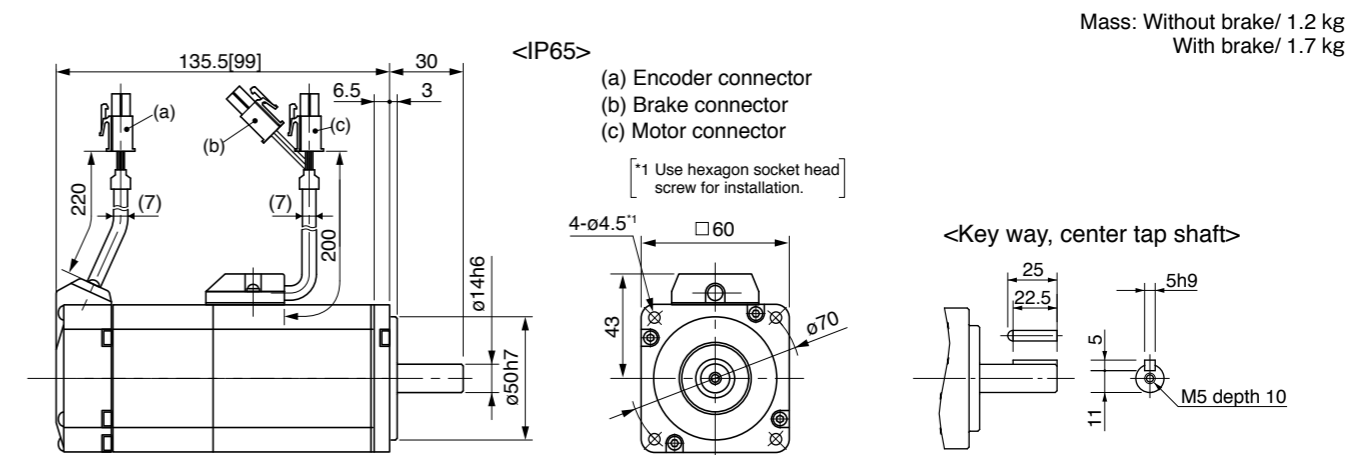

\* Figures in [ ] represent the dimensions without brake.

[Unit: mm]

<Cautions> Reduce the moment of inertia ratio if high speed response operation is required. Dimensions are subject to change without notice. Contact us or a dealer for the latest information. Read the Instruction Manual carefully and understand all precautions and remarks before using the products. Please avoid the motor, or equipment containing the motor to be distributed to Japan, or other regions through Japan.

\* Please contact us for more information.

Specifications

		AC200 V	
Motor model *1	IP65	MSMJ082G1□	MSMJ082S1□
	IP67	-	-
Applicable driver *2	Model No.	A5I series	MCDKT3520
	A5IE series	MCDKT3520E	-
Frame symbol		C-frame	
Power supply capacity (kVA)	1.3		
Rated output (W)	750		
Rated torque (N·m)	2.4		
Momentary Max. peak torque (N·m)	7.1		
Rated current (A(rms))	4.0		
Max. current (A(o-p))	17.0		
Regenerative brake frequency (times/min) Note1	Without option	No limit	Note2
	DV0P4283	No limit	Note2
Rated rotational speed (r/min)	3000		
Max. rotational speed (r/min)	4500		
Moment of inertia of rotor (×10 <sup>-4</sup> kg·m <sup>2</sup> )	Without brake	0.87	
	With brake	0.97	
Recommended moment of inertia ratio of the load and the rotor Note3	20 times or less		
Rotary encoder specifications Note5	20-bit Incremental	17-bit Absolute	
	Resolution per single turn	1,048,576	131,072

• **Brake specifications** (For details, refer to P.183)  
 (This brake will be released when it is energized.)  
 (Do not use this for braking the motor in motion.)

Static friction torque (N·m)	2.45 or more
Engaging time (ms)	70 or less
Releasing time (ms) Note4	20 or less
Exciting current (DC) (A)	0.42
Releasing voltage (DC) (V)	1 or more
Exciting voltage (DC) (V)	24±1.2

• **Permissible load** (For details, refer to P.183)

During assembly	Radial load P-direction (N)	686
	Thrust load A-direction (N)	294
	Thrust load B-direction (N)	392
During operation	Radial load P-direction (N)	392
	Thrust load A, B-direction (N)	147

• For details of Note 1 to Note 5, refer to P.182, 183.  
 • Dimensions of Driver, refer to P.43.

\*1 Motor specifications: □

\*2 The product that the end of driver model designation has "E" is "Position control type".  
 Detail of model designation, refer to P.152.

Torque characteristics (at AC200 V of power voltage <Dotted line represents the torque at 10 % less supply voltage.>)

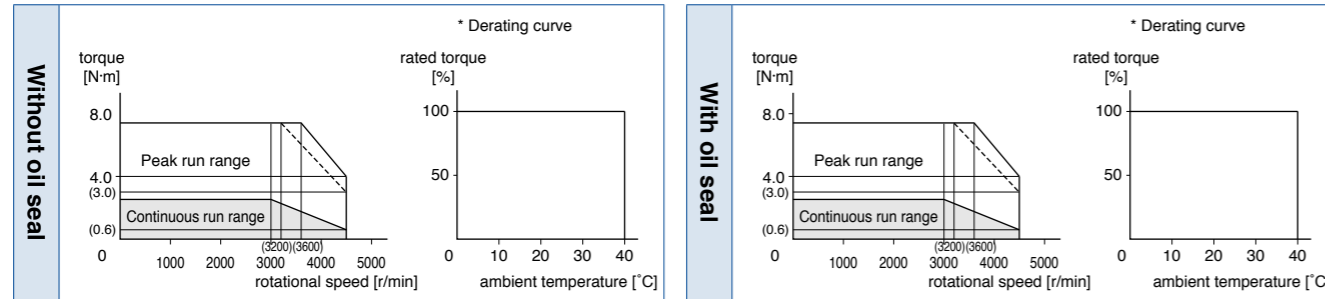

Dimensions

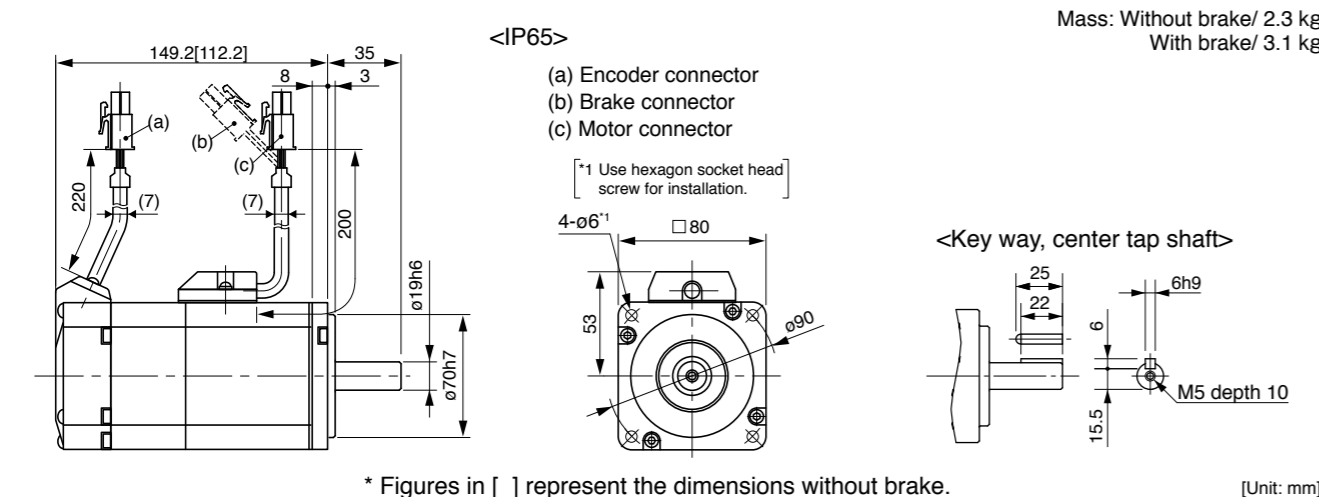

\* Figures in [ ] represent the dimensions without brake.

[Unit: mm]

<Cautions> Reduce the moment of inertia ratio if high speed response operation is required. Dimensions are subject to change without notice. Contact us or a dealer for the latest information. Read the Instruction Manual carefully and understand all precautions and remarks before using the products. Please avoid the motor, or equipment containing the motor to be distributed to Japan, or other regions through Japan.

\* Please contact us for more information.

Specifications

		AC200 V	
Motor model *1	IP65	MSME102GC□M	MSME102SC□M
	IP67	-	-
Applicable driver *2	Model No.	A5I series	MDDKT5540
	A5IE series	MDDKT5540E	-
Frame symbol		D-frame	
Power supply capacity (kVA)	1.8		
Rated output (W)	1000		
Rated torque (N·m)	3.18		
Momentary Max. peak torque (N·m)	9.55		
Rated current (A(rms))	6.6		
Max. current (A(o-p))	28		
Regenerative brake frequency (times/min) Note1	Without option	No limit	Note2
	DV0P4284	No limit	Note2
Rated rotational speed (r/min)	3000		
Max. rotational speed (r/min)	5000		
Moment of inertia of rotor (×10 <sup>-4</sup> kg·m <sup>2</sup> )	Without brake	2.03	
	With brake	2.35	
Recommended moment of inertia ratio of the load and the rotor Note3	15 times or less		
Rotary encoder specifications Note5	20-bit Incremental	17-bit Absolute	
	Resolution per single turn	1,048,576	131,072

• **Brake specifications** (For details, refer to P.183)  
 (This brake will be released when it is energized.)  
 (Do not use this for braking the motor in motion.)

Static friction torque (N·m)	7.8 or more
Engaging time (ms)	50 or less
Releasing time (ms) Note4	15 or less
Exciting current (DC) (A)	0.81±10 %
Releasing voltage (DC) (V)	2 or more
Exciting voltage (DC) (V)	24±2.4

• **Permissible load** (For details, refer to P.183)

During assembly	Radial load P-direction (N)	980
	Thrust load A-direction (N)	588
	Thrust load B-direction (N)	686
During operation	Radial load P-direction (N)	490
	Thrust load A, B-direction (N)	196

• For details of Note 1 to Note 5, refer to P.182, 183.  
 • Dimensions of Driver, refer to P.43.

\*1 Motor specifications: □

\*2 The product that the end of driver model designation has "E" is "Position control type".  
 Detail of model designation, refer to P.152.

Torque characteristics (at AC200 V of power voltage <Dotted line represents the torque at 10 % less supply voltage.>)

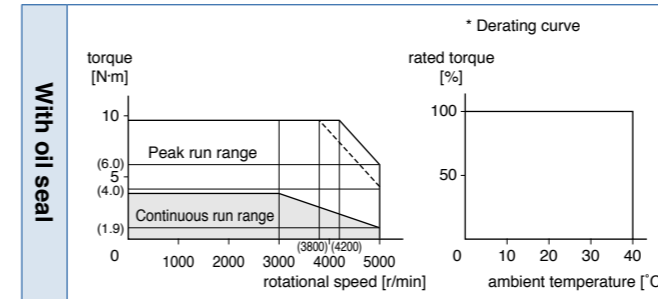

Dimensions

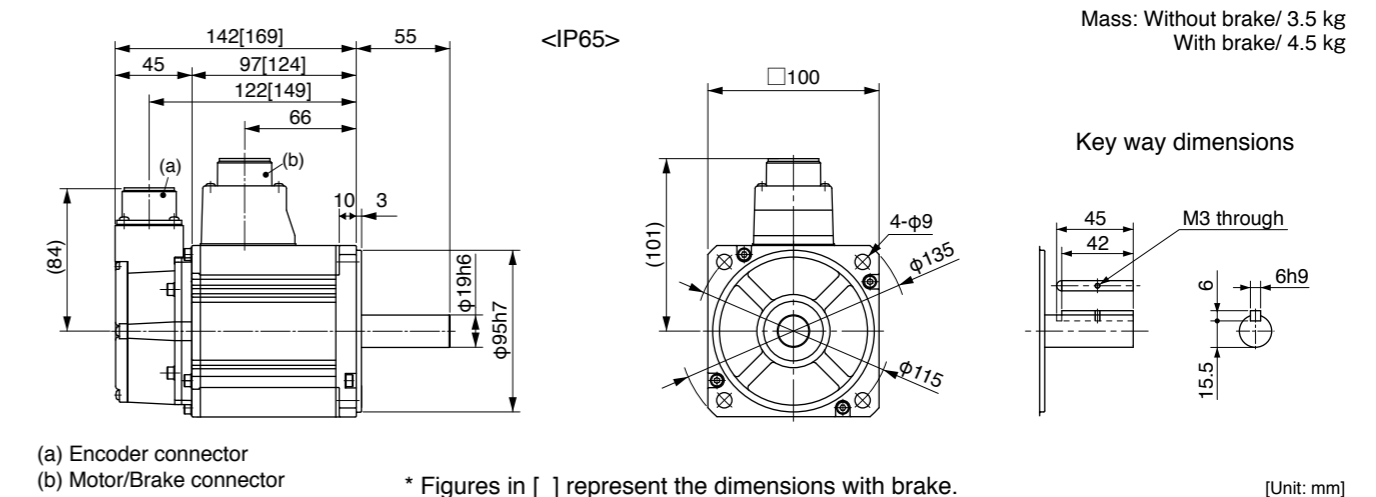

\* Figures in [ ] represent the dimensions with brake.

[Unit: mm]

<Cautions> Reduce the moment of inertia ratio if high speed response operation is required. Dimensions are subject to change without notice. Contact us or a dealer for the latest information. Read the Instruction Manual carefully and understand all precautions and remarks before using the products. Please avoid the motor, or equipment containing the motor to be distributed to Japan, or other regions through Japan.



\* Please contact us for more information.

Specifications

		AC200 V	
Motor model *1	IP65	MSME152GC□M	MSME152SC□M
	IP67	-	-
Applicable driver *2	Model No.	A5I series	MDDKT5540
	A5IE series	MDDKT5540E	-
Frame symbol		D-frame	
Power supply capacity (kVA)	2.3		
Rated output (W)	1500		
Rated torque (N·m)	4.77		
Momentary Max. peak torque (N·m)	14.3		
Rated current (A(rms))	8.2		
Max. current (A(o-p))	35		
Regenerative brake frequency (times/min) Note1	Without option	No limit Note2	
	DV0P4284	No limit Note2	
Rated rotational speed (r/min)	3000		
Max. rotational speed (r/min)	5000		
Moment of inertia of rotor (×10 <sup>-4</sup> kg·m <sup>2</sup> )	Without brake	2.84	
	With brake	3.17	
Recommended moment of inertia ratio of the load and the rotor Note3	15 times or less		
Rotary encoder specifications Note5	20-bit Incremental	17-bit Absolute	
	Resolution per single turn	1,048,576	131,072

• **Brake specifications** (For details, refer to P.183)  
 (This brake will be released when it is energized.)  
 (Do not use this for braking the motor in motion.)

Static friction torque (N·m)	7.8 or more
Engaging time (ms)	50 or less
Releasing time (ms) Note4	15 or less
Exciting current (DC) (A)	0.81±10 %
Releasing voltage (DC) (V)	2 or more
Exciting voltage (DC) (V)	24±2.4

• **Permissible load** (For details, refer to P.183)

During assembly	Radial load P-direction (N)	980
	Thrust load A-direction (N)	588
	Thrust load B-direction (N)	686
During operation	Radial load P-direction (N)	490
	Thrust load A, B-direction (N)	196

• For details of Note 1 to Note 5, refer to P.182, 183.

• Dimensions of Driver, refer to P.43.

\*1 Motor specifications: □

\*2 The product that the end of driver model designation has "E" is "Position control type".  
 Detail of model designation, refer to P.152.

Torque characteristics (at AC200 V of power voltage <Dotted line represents the torque at 10 % less supply voltage.>)

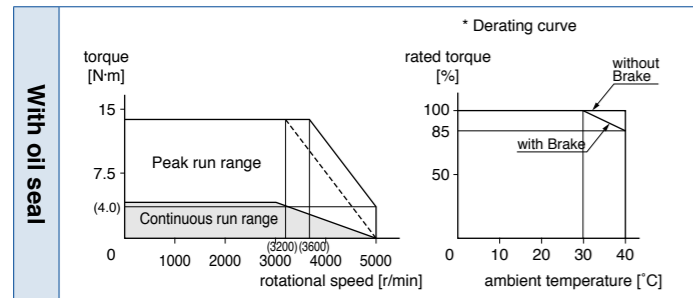

Dimensions

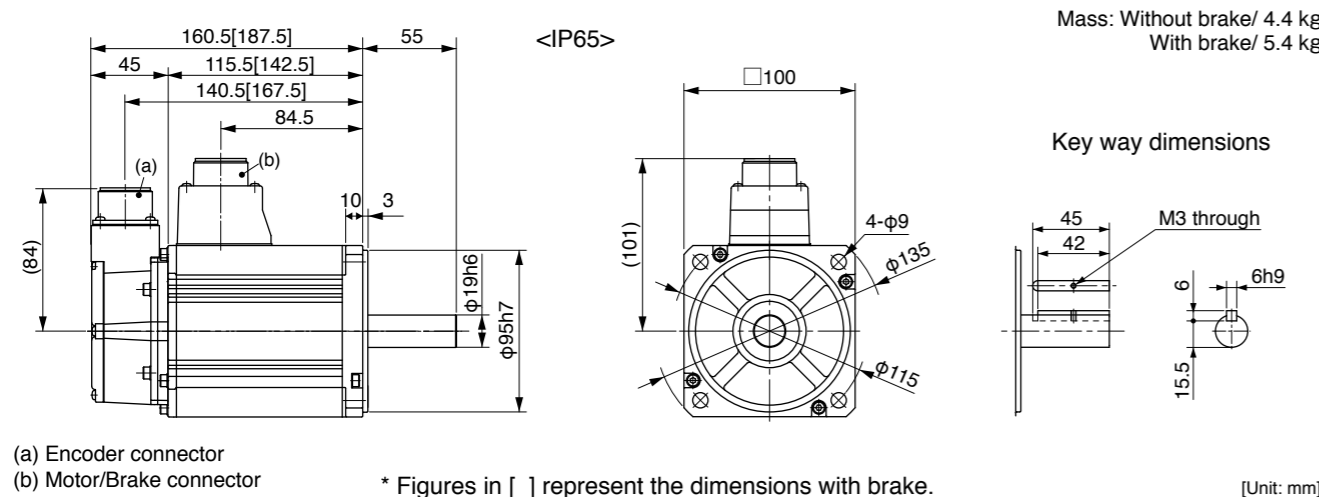

(a) Encoder connector  
 (b) Motor/Brake connector  
 \* Figures in [ ] represent the dimensions with brake.  
 [Unit: mm]  
**<Cautions>** Reduce the moment of inertia ratio if high speed response operation is required.  
 Dimensions are subject to change without notice. Contact us or a dealer for the latest information.  
 Read the Instruction Manual carefully and understand all precautions and remarks before using the products.  
 Please avoid the motor, or equipment containing the motor to be distributed to Japan, or other regions through Japan.

\* Please contact us for more information.

Specifications

		AC200 V	
Motor model *1	IP65	MSME202GC□M	MSME202SC□M
	IP67	-	-
Applicable driver *2	Model No.	A5I series	MEDKT7364
	A5IE series	MEDKT7364E	-
Frame symbol		E-frame	
Power supply capacity (kVA)	3.3		
Rated output (W)	2000		
Rated torque (N·m)	6.37		
Momentary Max. peak torque (N·m)	19.1		
Rated current (A(rms))	11.3		
Max. current (A(o-p))	48		
Regenerative brake frequency (times/min) Note1	Without option	No limit Note2	
	DV0P4285	No limit Note2	
Rated rotational speed (r/min)	3000		
Max. rotational speed (r/min)	5000		
Moment of inertia of rotor (×10 <sup>-4</sup> kg·m <sup>2</sup> )	Without brake	3.68	
	With brake	4.01	
Recommended moment of inertia ratio of the load and the rotor Note3	15 times or less		
Rotary encoder specifications Note5	20-bit Incremental	17-bit Absolute	
	Resolution per single turn	1,048,576	131,072

• **Brake specifications** (For details, refer to P.183)  
 (This brake will be released when it is energized.)  
 (Do not use this for braking the motor in motion.)

Static friction torque (N·m)	7.8 or more
Engaging time (ms)	50 or less
Releasing time (ms) Note4	15 or less
Exciting current (DC) (A)	0.81±10 %
Releasing voltage (DC) (V)	2 or more
Exciting voltage (DC) (V)	24±2.4

• **Permissible load** (For details, refer to P.183)

During assembly	Radial load P-direction (N)	980
	Thrust load A-direction (N)	588
	Thrust load B-direction (N)	686
During operation	Radial load P-direction (N)	490
	Thrust load A, B-direction (N)	196

• For details of Note 1 to Note 5, refer to P.182, 183.

• Dimensions of Driver, refer to P.44.

\*1 Motor specifications: □

\*2 The product that the end of driver model designation has "E" is "Position control type".  
 Detail of model designation, refer to P.152.

Torque characteristics (at AC200 V of power voltage <Dotted line represents the torque at 10 % less supply voltage.>)

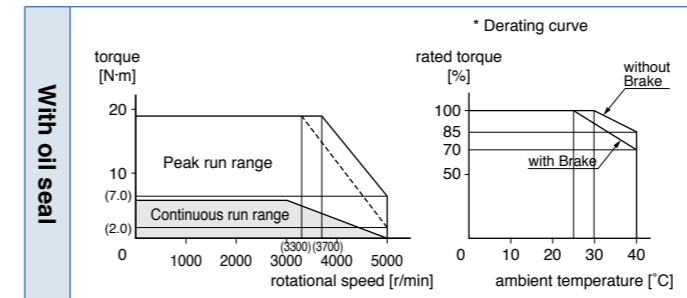

Dimensions

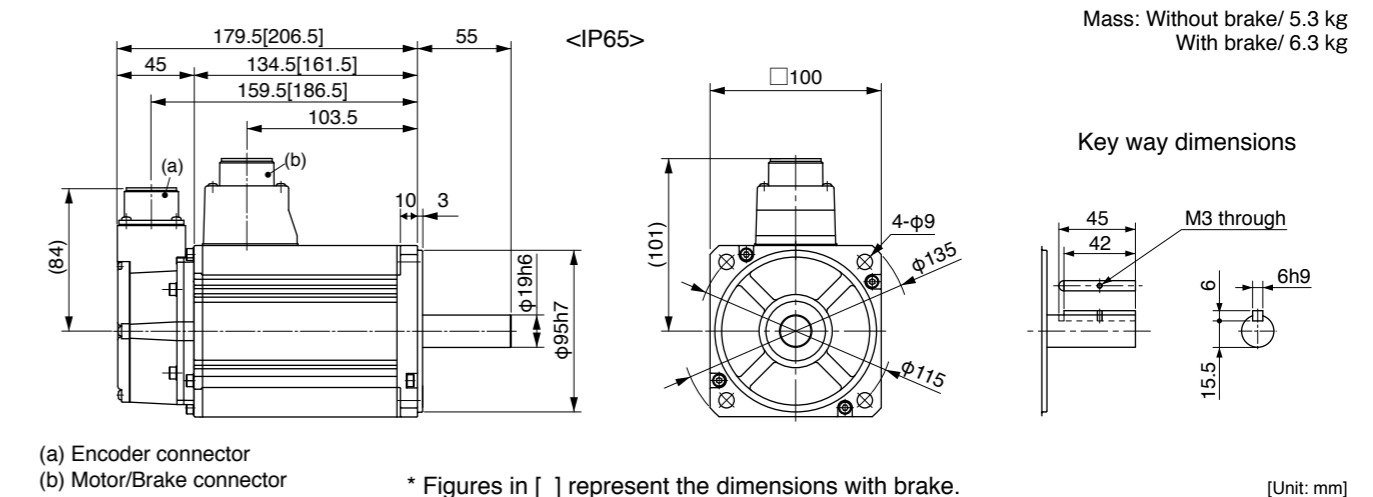

(a) Encoder connector  
 (b) Motor/Brake connector  
 \* Figures in [ ] represent the dimensions with brake.  
 [Unit: mm]  
**<Cautions>** Reduce the moment of inertia ratio if high speed response operation is required.  
 Dimensions are subject to change without notice. Contact us or a dealer for the latest information.  
 Read the Instruction Manual carefully and understand all precautions and remarks before using the products.  
 Please avoid the motor, or equipment containing the motor to be distributed to Japan, or other regions through Japan.

\* Please contact us for more information.

Specifications

		AC200 V	
Motor model *1	IP65		MSME302GC□M MSME302SC□M
	IP67		- -
Applicable driver *2	Model No.	A5I series	MFDKTA390
		A5IE series	MFDKTA390E -
		Frame symbol	F-frame
Power supply capacity (kVA)		4.5	
Rated output (W)		3000	
Rated torque (N·m)		9.55	
Momentary Max. peak torque (N·m)		28.6	
Rated current (A(rms))		18.1	
Max. current (A(o-p))		77	
Regenerative brake frequency (times/min) Note1	Without option	No limit Note2	
	DV0P4285×2	No limit Note2	
Rated rotational speed (r/min)		3000	
Max. rotational speed (r/min)		5000	
Moment of inertia of rotor (×10 <sup>-4</sup> kg·m <sup>2</sup> )	Without brake	6.50	
	With brake	7.85	
Recommended moment of inertia ratio of the load and the rotor Note3		15 times or less	
Rotary encoder specifications Note5	20-bit Incremental		17-bit Absolute
	Resolution per single turn		1,048,576 131,072

• **Brake specifications** (For details, refer to P.183)  
 (This brake will be released when it is energized.)  
 (Do not use this for braking the motor in motion.)

Static friction torque (N·m)	11.8 or more
Engaging time (ms)	80 or less
Releasing time (ms) Note4	15 or less
Exciting current (DC) (A)	0.81±10 %
Releasing voltage (DC) (V)	2 or more
Exciting voltage (DC) (V)	24±2.4

• **Permissible load** (For details, refer to P.183)

During assembly	Radial load P-direction (N)	980
	Thrust load A-direction (N)	588
	Thrust load B-direction (N)	686
During operation	Radial load P-direction (N)	490
	Thrust load A, B-direction (N)	196

• For details of Note 1 to Note 5, refer to P.182, 183.

• Dimensions of Driver, refer to P.45.

\*1 Motor specifications: □

\*2 The product that the end of driver model designation has "E" is "Position control type".  
 Detail of model designation, refer to P.152.

Torque characteristics (at AC200 V of power voltage <Dotted line represents the torque at 10 % less supply voltage.>)

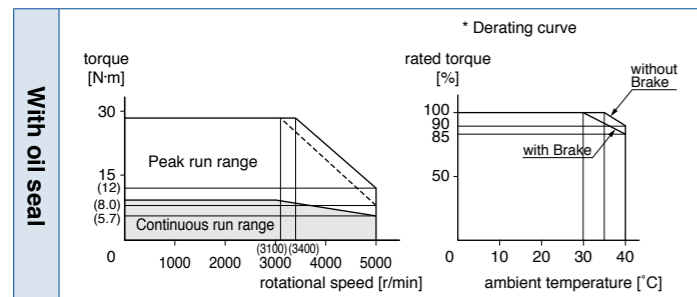

Dimensions

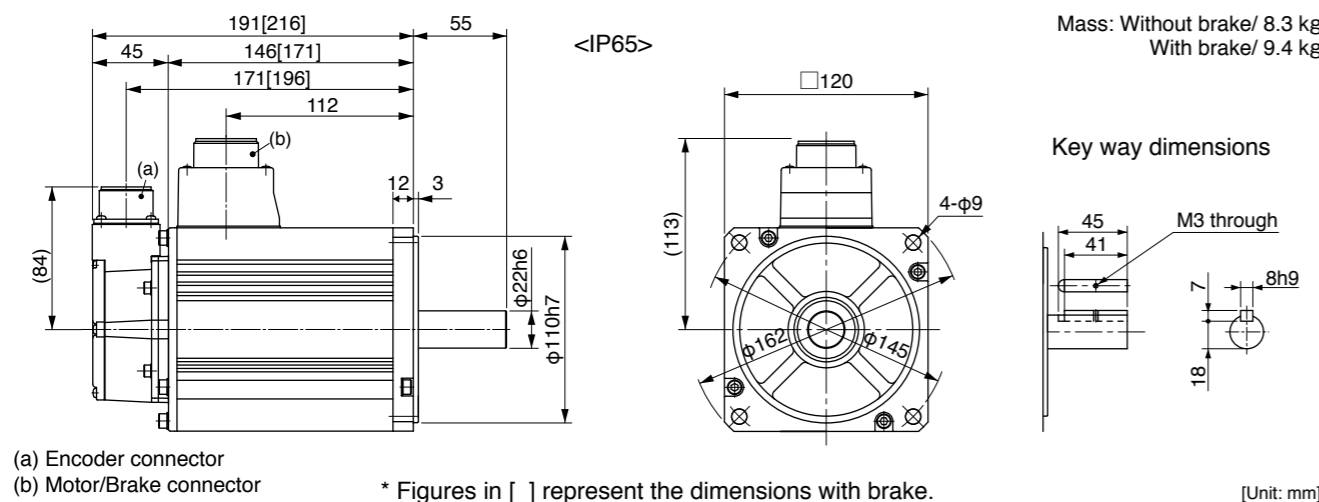

(a) Encoder connector  
 (b) Motor/Brake connector  
 \* Figures in [ ] represent the dimensions with brake.  
 [Unit: mm]  
**<Cautions>** Reduce the moment of inertia ratio if high speed response operation is required.  
 Dimensions are subject to change without notice. Contact us or a dealer for the latest information.  
 Read the Instruction Manual carefully and understand all precautions and remarks before using the products.  
 Please avoid the motor, or equipment containing the motor to be distributed to Japan, or other regions through Japan.

\* Please contact us for more information.

Specifications

		AC200 V	
Motor model *1	IP65		MSME402GC□M MSME402SC□M
	IP67		- -
Applicable driver *2	Model No.	A5I series	MFDKTB3A2
		A5IE series	MFDKTB3A2E -
		Frame symbol	F-frame
Power supply capacity (kVA)		6.0	
Rated output (W)		4000	
Rated torque (N·m)		12.7	
Momentary Max. peak torque (N·m)		38.2	
Rated current (A(rms))		19.6	
Max. current (A(o-p))		83	
Regenerative brake frequency (times/min) Note1	Without option	No limit Note2	
	DV0P4285×2	No limit Note2	
Rated rotational speed (r/min)		3000	
Max. rotational speed (r/min)		4500	
Moment of inertia of rotor (×10 <sup>-4</sup> kg·m <sup>2</sup> )	Without brake	12.9	
	With brake	14.2	
Recommended moment of inertia ratio of the load and the rotor Note3		15 times or less	
Rotary encoder specifications Note5	20-bit Incremental		17-bit Absolute
	Resolution per single turn		1,048,576 131,072

• **Brake specifications** (For details, refer to P.183)  
 (This brake will be released when it is energized.)  
 (Do not use this for braking the motor in motion.)

Static friction torque (N·m)	16.2 or more
Engaging time (ms)	110 or less
Releasing time (ms) Note4	50 or less
Exciting current (DC) (A)	0.90±10 %
Releasing voltage (DC) (V)	2 or more
Exciting voltage (DC) (V)	24±2.4

• **Permissible load** (For details, refer to P.183)

During assembly	Radial load P-direction (N)	980
	Thrust load A-direction (N)	588
	Thrust load B-direction (N)	686
During operation	Radial load P-direction (N)	784
	Thrust load A, B-direction (N)	343

• For details of Note 1 to Note 5, refer to P.182, 183.

• Dimensions of Driver, refer to P.45.

\*1 Motor specifications: □

\*2 The product that the end of driver model designation has "E" is "Position control type".  
 Detail of model designation, refer to P.152.

Torque characteristics (at AC200 V of power voltage <Dotted line represents the torque at 10 % less supply voltage.>)

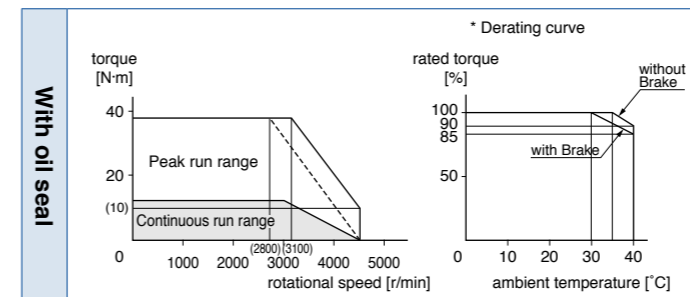

Dimensions

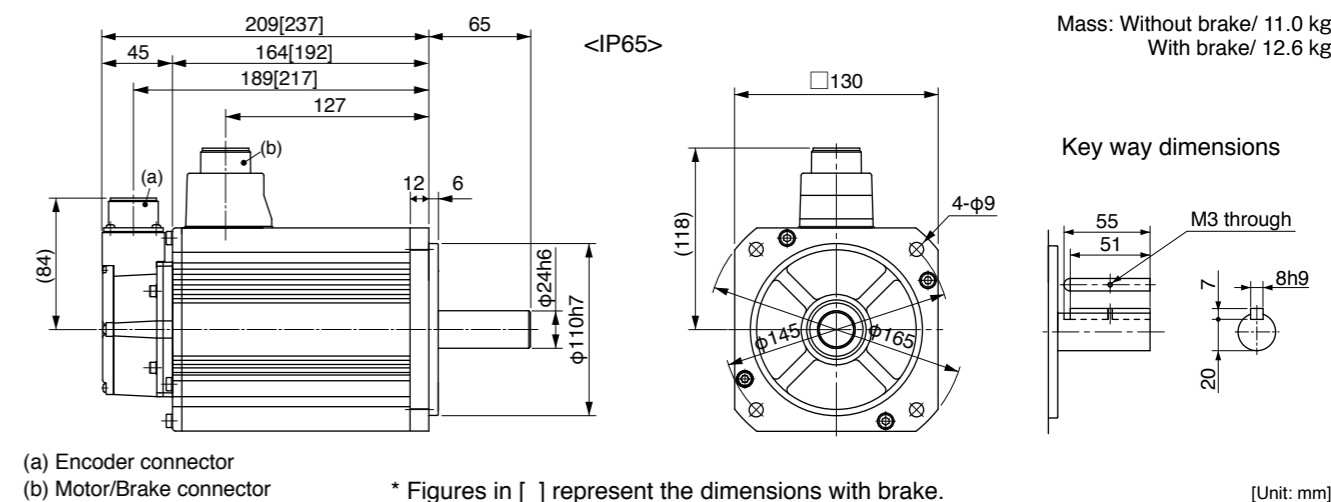

(a) Encoder connector  
 (b) Motor/Brake connector  
 \* Figures in [ ] represent the dimensions with brake.  
 [Unit: mm]  
**<Cautions>** Reduce the moment of inertia ratio if high speed response operation is required.  
 Dimensions are subject to change without notice. Contact us or a dealer for the latest information.  
 Read the Instruction Manual carefully and understand all precautions and remarks before using the products.  
 Please avoid the motor, or equipment containing the motor to be distributed to Japan, or other regions through Japan.

\* Please contact us for more information.

Specifications

		AC200 V	
Motor model *1	IP65	MSME502GC□M	MSME502SC□M
	IP67	-	-
Applicable driver *2	Model No.	A5I series	MFDKTB3A2
	A5IE series	MFDKTB3A2E	-
Frame symbol		F-frame	
Power supply capacity (kVA)	7.5		
Rated output (W)	5000		
Rated torque (N·m)	15.9		
Momentary Max. peak torque (N·m)	47.7		
Rated current (A(rms))	24.0		
Max. current (A(o-p))	102		
Regenerative brake frequency (times/min) Note1	Without option	357	
	DV0P4285×2	No limit Note2	
Rated rotational speed (r/min)	3000		
Max. rotational speed (r/min)	4500		
Moment of inertia of rotor (×10 <sup>-4</sup> kg·m <sup>2</sup> )	Without brake	17.4	
	With brake	18.6	
Recommended moment of inertia ratio of the load and the rotor Note3	15 times or less		
Rotary encoder specifications Note5	20-bit Incremental	17-bit Absolute	
	Resolution per single turn	1,048,576	131,072

• Brake specifications (For details, refer to P.183)

(This brake will be released when it is energized.)  
(Do not use this for braking the motor in motion.)

Static friction torque (N·m)	16.2 or more
Engaging time (ms)	110 or less
Releasing time (ms) Note4	50 or less
Exciting current (DC) (A)	0.90±10 %
Releasing voltage (DC) (V)	2 or more
Exciting voltage (DC) (V)	24±2.4

• Permissible load (For details, refer to P.183)

During assembly	Radial load P-direction (N)	980
	Thrust load A-direction (N)	588
	Thrust load B-direction (N)	686
During operation	Radial load P-direction (N)	784
	Thrust load A, B-direction (N)	343

• For details of Note 1 to Note 5, refer to P.182, 183.

• Dimensions of Driver, refer to P.45.

\*1 Motor specifications: □

\*2 The product that the end of driver model designation has "E" is "Position control type".  
Detail of model designation, refer to P.152.

Torque characteristics (at AC200 V of power voltage <Dotted line represents the torque at 10 % less supply voltage.>)

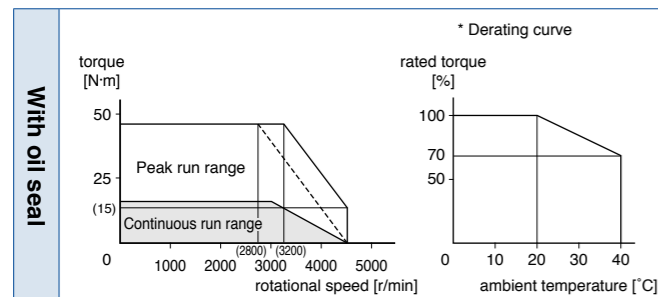

Dimensions

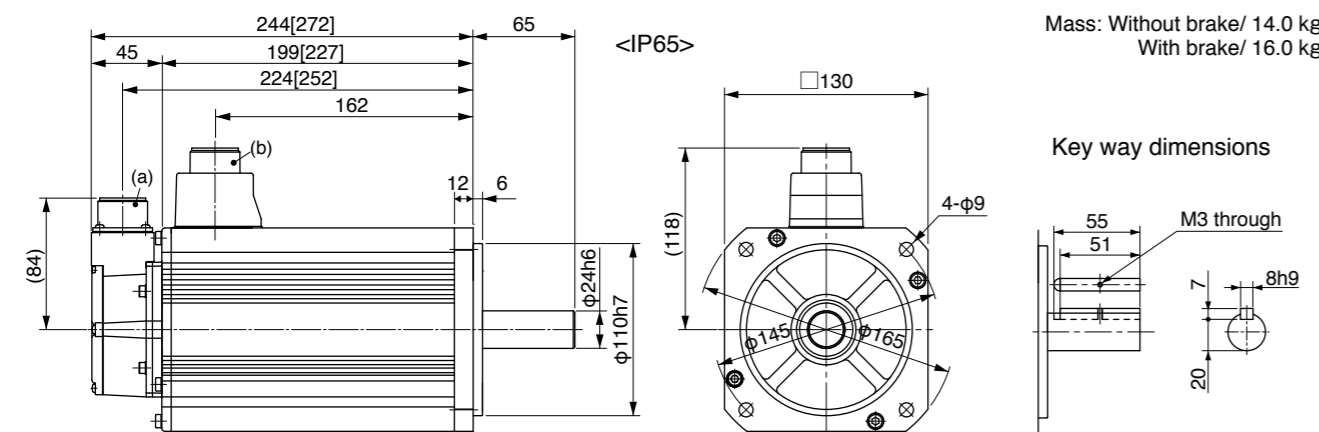

Mass: Without brake/ 14.0 kg  
With brake/ 16.0 kg

Key way dimensions

(a) Encoder connector  
(b) Motor/Brake connector

\* Figures in [ ] represent the dimensions with brake.

[Unit: mm]

<Cautions> Reduce the moment of inertia ratio if high speed response operation is required. Dimensions are subject to change without notice. Contact us or a dealer for the latest information. Read the Instruction Manual carefully and understand all precautions and remarks before using the products. Please avoid the motor, or equipment containing the motor to be distributed to Japan, or other regions through Japan.

\* Please contact us for more information.

Specifications

		AC200 V	
Motor model *1	IP65	MDME102GC□M	MDME102SC□M
	IP67	-	-
Applicable driver *2	Model No.	A5I series	MDDKT3530
	A5IE series	MDDKT3530E	-
Frame symbol		D-frame	
Power supply capacity (kVA)	1.8		
Rated output (W)	1000		
Rated torque (N·m)	4.77		
Momentary Max. peak torque (N·m)	14.3		
Rated current (A(rms))	5.7		
Max. current (A(o-p))	24		
Regenerative brake frequency (times/min) Note1	Without option	No limit Note2	
	DV0P4284	No limit Note2	
Rated rotational speed (r/min)	2000		
Max. rotational speed (r/min)	3000		
Moment of inertia of rotor (×10 <sup>-4</sup> kg·m <sup>2</sup> )	Without brake	4.60	
	With brake	5.90	
Recommended moment of inertia ratio of the load and the rotor Note3	10 times or less		
Rotary encoder specifications Note5	20-bit Incremental	17-bit Absolute	
	Resolution per single turn	1,048,576	131,072

• Brake specifications (For details, refer to P.183)

(This brake will be released when it is energized.)  
(Do not use this for braking the motor in motion.)

Static friction torque (N·m)	4.9 or more
Engaging time (ms)	80 or less
Releasing time (ms) Note4	70 or less
Exciting current (DC) (A)	0.59±10 %
Releasing voltage (DC) (V)	2 or more
Exciting voltage (DC) (V)	24±2.4

• Permissible load (For details, refer to P.183)

During assembly	Radial load P-direction (N)	980
	Thrust load A-direction (N)	588
	Thrust load B-direction (N)	686
During operation	Radial load P-direction (N)	490
	Thrust load A, B-direction (N)	196

• For details of Note 1 to Note 5, refer to P.182, 183.

• Dimensions of Driver, refer to P.43.

\*1 Motor specifications: □

\*2 The product that the end of driver model designation has "E" is "Position control type".  
Detail of model designation, refer to P.152.

Torque characteristics (at AC200 V of power voltage <Dotted line represents the torque at 10 % less supply voltage.>)

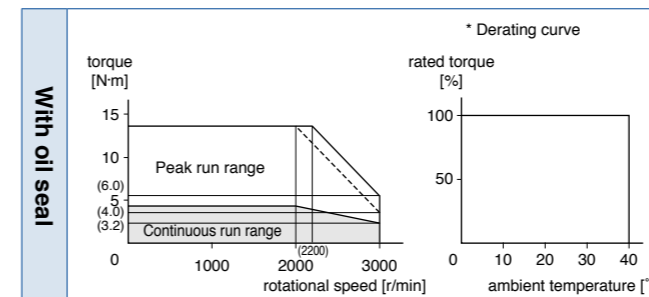

Dimensions

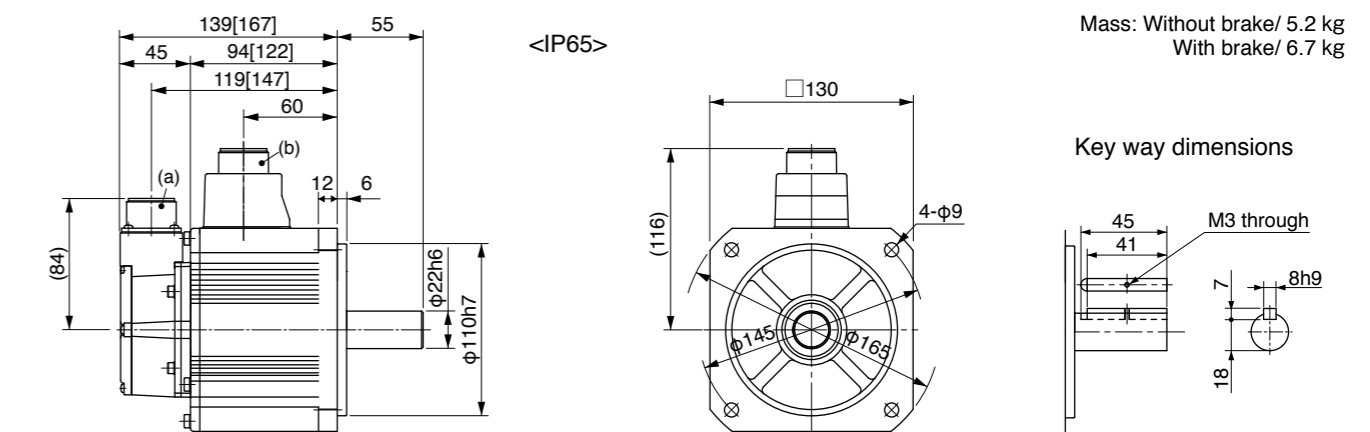

Mass: Without brake/ 5.2 kg  
With brake/ 6.7 kg

Key way dimensions

(a) Encoder connector  
(b) Motor/Brake connector

\* Figures in [ ] represent the dimensions with brake.

[Unit: mm]

<Cautions> Reduce the moment of inertia ratio if high speed response operation is required. Dimensions are subject to change without notice. Contact us or a dealer for the latest information. Read the Instruction Manual carefully and understand all precautions and remarks before using the products. Please avoid the motor, or equipment containing the motor to be distributed to Japan, or other regions through Japan.

\* Please contact us for more information.

Specifications

		AC200 V		
Motor model *1	IP65		MDME152GC□M	MDME152SC□M
	IP67		-	-
Applicable driver *2	Model No.	A5I series	MDDKT5540	
		A5IE series	MDDKT5540E	-
		Frame symbol	D-frame	
Power supply capacity (kVA)		2.3		
Rated output (W)		1500		
Rated torque (N·m)		7.16		
Momentary Max. peak torque (N·m)		21.5		
Rated current (A(rms))		9.4		
Max. current (A(o-p))		40		
Regenerative brake frequency (times/min) Note1	Without option		No limit Note2	
	DV0P4284		No limit Note2	
Rated rotational speed (r/min)		2000		
Max. rotational speed (r/min)		3000		
Moment of inertia of rotor (×10 <sup>-4</sup> kg·m <sup>2</sup> )	Without brake		6.70	
	With brake		7.99	
Recommended moment of inertia ratio of the load and the rotor Note3		10 times or less		
Rotary encoder specifications Note5	20-bit Incremental		17-bit Absolute	
	Resolution per single turn		1,048,576	131,072

• **Brake specifications** (For details, refer to P.183)  
 (This brake will be released when it is energized.)  
 (Do not use this for braking the motor in motion.)

Static friction torque (N·m)	13.7 or more
Engaging time (ms)	100 or less
Releasing time (ms) Note4	50 or less
Exciting current (DC) (A)	0.79±10 %
Releasing voltage (DC) (V)	2 or more
Exciting voltage (DC) (V)	24±2.4

• **Permissible load** (For details, refer to P.183)

	Radial load P-direction (N)	980
During assembly	Thrust load A-direction (N)	588
	Thrust load B-direction (N)	686
	Radial load P-direction (N)	490
During operation	Thrust load A, B-direction (N)	196

• For details of Note 1 to Note 5, refer to P.182, 183.

• Dimensions of Driver, refer to P.43.

\*1 Motor specifications: □

\*2 The product that the end of driver model designation has "E" is "Position control type".  
 Detail of model designation, refer to P.152.

Torque characteristics (at AC200 V of power voltage <Dotted line represents the torque at 10 % less supply voltage.>)

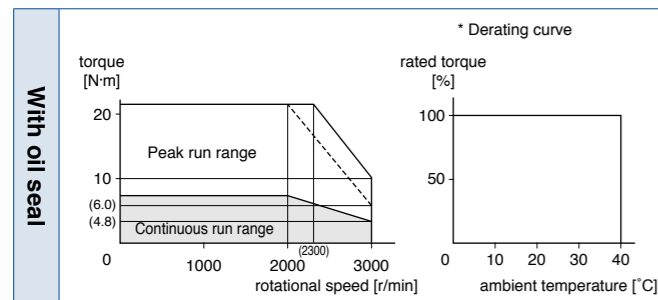

Dimensions

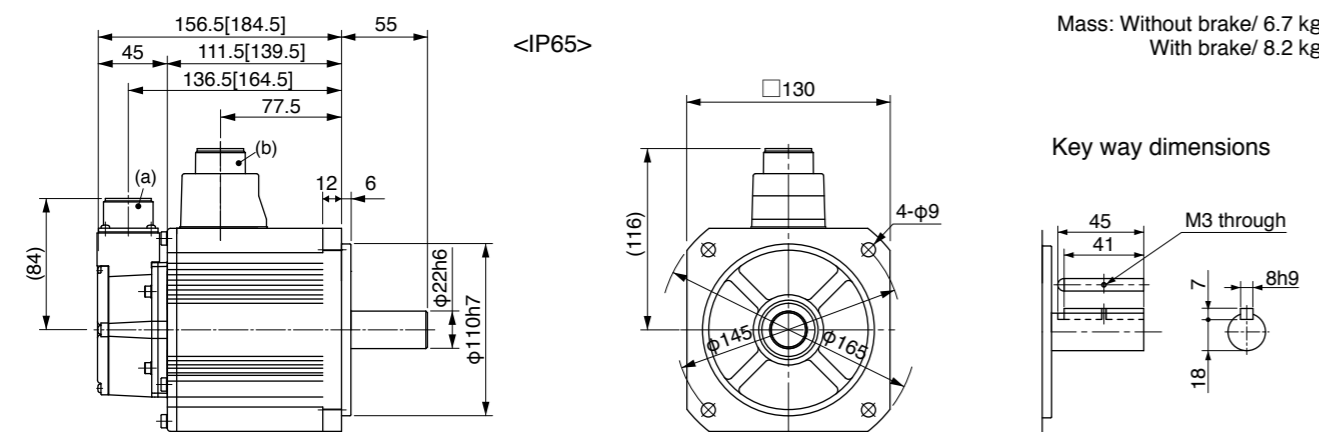

(a) Encoder connector  
 (b) Motor/Brake connector

\* Figures in [ ] represent the dimensions with brake.

[Unit: mm]

<Cautions> Reduce the moment of inertia ratio if high speed response operation is required. Dimensions are subject to change without notice. Contact us or a dealer for the latest information. Read the Instruction Manual carefully and understand all precautions and remarks before using the products. Please avoid the motor, or equipment containing the motor to be distributed to Japan, or other regions through Japan.

\* Please contact us for more information.

Specifications

		AC200 V		
Motor model *1	IP65		MDME202GC□M	MDME202SC□M
	IP67		-	-
Applicable driver *2	Model No.	A5I series	MEDKT7364	
		A5IE series	MEDKT7364E	-
		Frame symbol	E-frame	
Power supply capacity (kVA)		3.3		
Rated output (W)		2000		
Rated torque (N·m)		9.55		
Momentary Max. peak torque (N·m)		28.6		
Rated current (A(rms))		11.5		
Max. current (A(o-p))		49		
Regenerative brake frequency (times/min) Note1	Without option		No limit Note2	
	DV0P4285		No limit Note2	
Rated rotational speed (r/min)		2000		
Max. rotational speed (r/min)		3000		
Moment of inertia of rotor (×10 <sup>-4</sup> kg·m <sup>2</sup> )	Without brake		8.72	
	With brake		10.0	
Recommended moment of inertia ratio of the load and the rotor Note3		10 times or less		
Rotary encoder specifications Note5	20-bit Incremental		17-bit Absolute	
	Resolution per single turn		1,048,576	131,072

• **Brake specifications** (For details, refer to P.183)  
 (This brake will be released when it is energized.)  
 (Do not use this for braking the motor in motion.)

Static friction torque (N·m)	13.7 or more
Engaging time (ms)	100 or less
Releasing time (ms) Note4	50 or less
Exciting current (DC) (A)	0.79±10 %
Releasing voltage (DC) (V)	2 or more
Exciting voltage (DC) (V)	24±2.4

• **Permissible load** (For details, refer to P.183)

	Radial load P-direction (N)	980
During assembly	Thrust load A-direction (N)	588
	Thrust load B-direction (N)	686
	Radial load P-direction (N)	490
During operation	Thrust load A, B-direction (N)	196

• For details of Note 1 to Note 5, refer to P.182, 183.

• Dimensions of Driver, refer to P.43.

\*1 Motor specifications: □

\*2 The product that the end of driver model designation has "E" is "Position control type".  
 Detail of model designation, refer to P.152.

Torque characteristics (at AC200 V of power voltage <Dotted line represents the torque at 10 % less supply voltage.>)

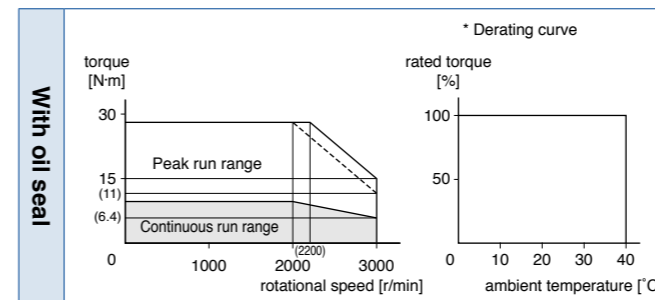

Dimensions

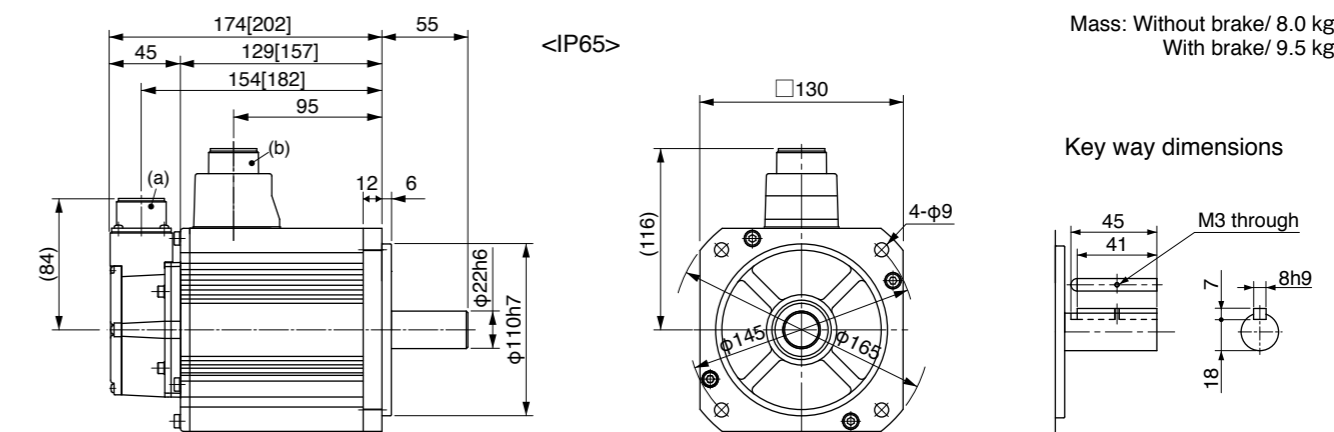

(a) Encoder connector  
 (b) Motor/Brake connector

\* Figures in [ ] represent the dimensions with brake.

[Unit: mm]

<Cautions> Reduce the moment of inertia ratio if high speed response operation is required. Dimensions are subject to change without notice. Contact us or a dealer for the latest information. Read the Instruction Manual carefully and understand all precautions and remarks before using the products. Please avoid the motor, or equipment containing the motor to be distributed to Japan, or other regions through Japan.

\* Please contact us for more information.

Specifications

		AC200 V	
Motor model *1	IP65	MDME302GC□M	MDME302SC□M
	IP67	-	-
Applicable driver *2	Model No.	A5II series MFDKTA390	-
	A5IE series	MFDKTA390E	-
Frame symbol		F-frame	
Power supply capacity (kVA)	4.5		
Rated output (W)	3000		
Rated torque (N·m)	14.3		
Momentary Max. peak torque (N·m)	43.0		
Rated current (A(rms))	17.4		
Max. current (A(o-p))	74		
Regenerative brake frequency (times/min) Note1	Without option	No limit Note2	
	DV0P4285×2	No limit Note2	
Rated rotational speed (r/min)	2000		
Max. rotational speed (r/min)	3000		
Moment of inertia of rotor (×10 <sup>-4</sup> kg·m <sup>2</sup> )	Without brake	12.9	
	With brake	14.2	
Recommended moment of inertia ratio of the load and the rotor Note3	10 times or less		
Rotary encoder specifications Note5	20-bit Incremental	17-bit Absolute	
	Resolution per single turn	1,048,576	131,072

• Brake specifications (For details, refer to P.183)

(This brake will be released when it is energized.)  
(Do not use this for braking the motor in motion.)

Static friction torque (N·m)	16.2 or more
Engaging time (ms)	110 or less
Releasing time (ms) Note4	50 or less
Exciting current (DC) (A)	0.90±10 %
Releasing voltage (DC) (V)	2 or more
Exciting voltage (DC) (V)	24±2.4

• Permissible load (For details, refer to P.183)

During assembly	Radial load P-direction (N)	980
	Thrust load A-direction (N)	588
	Thrust load B-direction (N)	686
During operation	Radial load P-direction (N)	784
	Thrust load A, B-direction (N)	343

• For details of Note 1 to Note 5, refer to P.182, 183.

• Dimensions of Driver, refer to P.45.

\*1 Motor specifications: □

\*2 The product that the end of driver model designation has "E" is "Position control type".  
Detail of model designation, refer to P.152.

Torque characteristics (at AC200 V of power voltage <Dotted line represents the torque at 10 % less supply voltage.>)

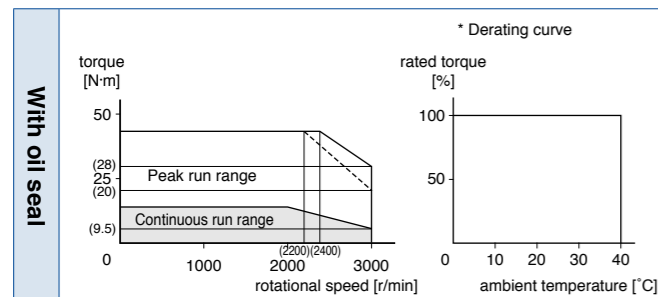

Dimensions

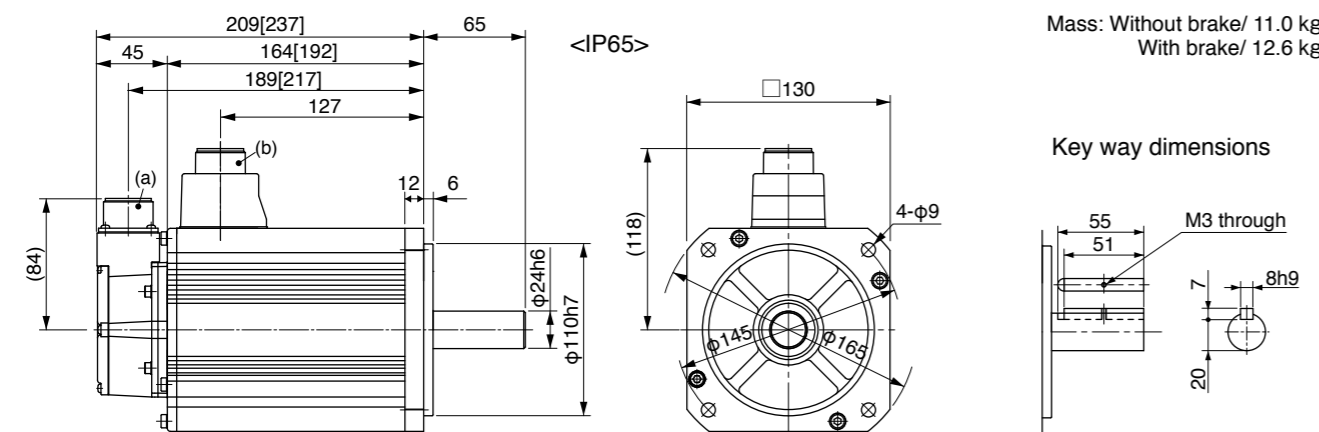

(a) Encoder connector  
(b) Motor/Brake connector

\* Figures in [ ] represent the dimensions with brake.

[Unit: mm]

<Cautions> Reduce the moment of inertia ratio if high speed response operation is required. Dimensions are subject to change without notice. Contact us or a dealer for the latest information. Read the Instruction Manual carefully and understand all precautions and remarks before using the products. Please avoid the motor, or equipment containing the motor to be distributed to Japan, or other regions through Japan.

\* Please contact us for more information.

Specifications

		AC200 V	
Motor model *1	IP65	MDME402GC□M	MDME402SC□M
	IP67	-	-
Applicable driver *2	Model No.	A5II series MFDKTB3A2	-
	A5IE series	MFDKTB3A2E	-
Frame symbol		F-frame	
Power supply capacity (kVA)	6.0		
Rated output (W)	4000		
Rated torque (N·m)	19.1		
Momentary Max. peak torque (N·m)	57.3		
Rated current (A(rms))	21.0		
Max. current (A(o-p))	89		
Regenerative brake frequency (times/min) Note1	Without option	No limit Note2	
	DV0P4285×2	No limit Note2	
Rated rotational speed (r/min)	2000		
Max. rotational speed (r/min)	3000		
Moment of inertia of rotor (×10 <sup>-4</sup> kg·m <sup>2</sup> )	Without brake	37.6	
	With brake	38.6	
Recommended moment of inertia ratio of the load and the rotor Note3	10 times or less		
Rotary encoder specifications Note5	20-bit Incremental	17-bit Absolute	
	Resolution per single turn	1,048,576	131,072

• Brake specifications (For details, refer to P.183)

(This brake will be released when it is energized.)  
(Do not use this for braking the motor in motion.)

Static friction torque (N·m)	24.5 or more
Engaging time (ms)	80 or less
Releasing time (ms) Note4	25 or less
Exciting current (DC) (A)	1.3±10 %
Releasing voltage (DC) (V)	2 or more
Exciting voltage (DC) (V)	24±2.4

• Permissible load (For details, refer to P.183)

During assembly	Radial load P-direction (N)	1666
	Thrust load A-direction (N)	784
	Thrust load B-direction (N)	980
During operation	Radial load P-direction (N)	784
	Thrust load A, B-direction (N)	343

• For details of Note 1 to Note 5, refer to P.182, 183.

• Dimensions of Driver, refer to P.45.

\*1 Motor specifications: □

\*2 The product that the end of driver model designation has "E" is "Position control type".  
Detail of model designation, refer to P.152.

Torque characteristics (at AC200 V of power voltage <Dotted line represents the torque at 10 % less supply voltage.>)

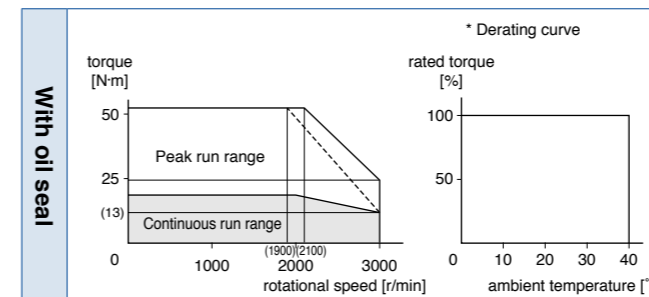

Dimensions

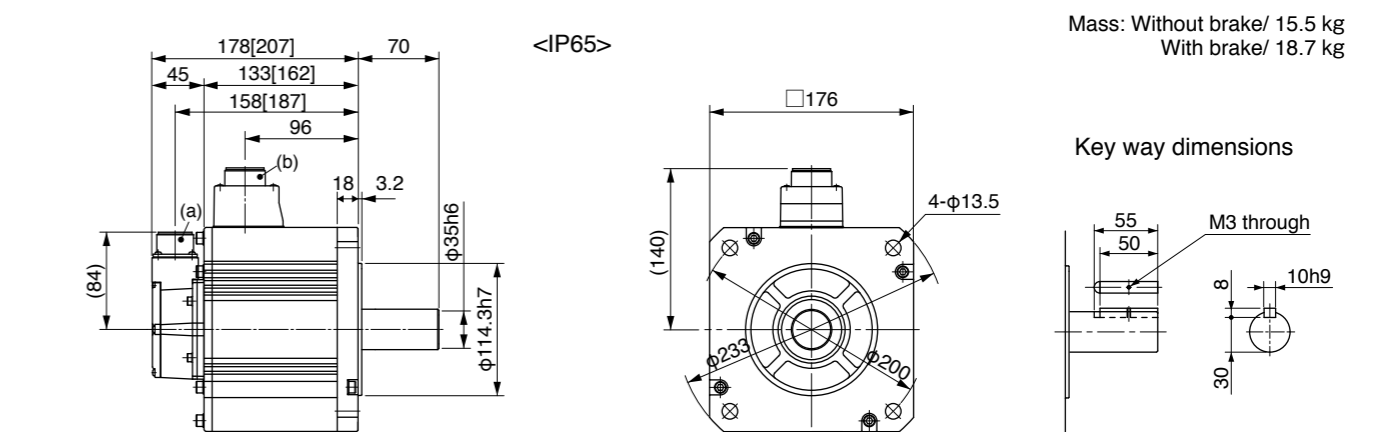

(a) Encoder connector  
(b) Motor/Brake connector

\* Figures in [ ] represent the dimensions with brake.

[Unit: mm]

<Cautions> Reduce the moment of inertia ratio if high speed response operation is required. Dimensions are subject to change without notice. Contact us or a dealer for the latest information. Read the Instruction Manual carefully and understand all precautions and remarks before using the products. Please avoid the motor, or equipment containing the motor to be distributed to Japan, or other regions through Japan.

\* Please contact us for more information.

Specifications

		AC200 V	
Motor model *1	IP65	MDME502GC□M	MDME502SC□M
	IP67	-	-
Applicable driver *2	Model No.	A5II series MFDKTB3A2	-
	A5IE series	MFDKTB3A2E	-
Frame symbol		F-frame	
Power supply capacity (kVA)	7.5		
Rated output (W)	5000		
Rated torque (N·m)	23.9		
Momentary Max. peak torque (N·m)	71.6		
Rated current (A(rms))	25.9		
Max. current (A(o-p))	110		
Regenerative brake frequency (times/min) Note1	Without option	120	
	DV0P4285×2	No limit Note2	
Rated rotational speed (r/min)	2000		
Max. rotational speed (r/min)	3000		
Moment of inertia of rotor (×10 <sup>-4</sup> kg·m <sup>2</sup> )	Without brake	48.0	
	With brake	48.8	
Recommended moment of inertia ratio of the load and the rotor Note3	10 times or less		
Rotary encoder specifications Note5	20-bit Incremental	17-bit Absolute	
	Resolution per single turn	1,048,576	131,072

• **Brake specifications** (For details, refer to P.183)  
(This brake will be released when it is energized.)  
(Do not use this for braking the motor in motion.)

Static friction torque (N·m)	24.5 or more
Engaging time (ms)	80 or less
Releasing time (ms) Note4	25 or less
Exciting current (DC) (A)	1.3±10 %
Releasing voltage (DC) (V)	2 or more
Exciting voltage (DC) (V)	24±2.4

• **Permissible load** (For details, refer to P.183)

During assembly	Radial load P-direction (N)	1666
	Thrust load A-direction (N)	784
	Thrust load B-direction (N)	980
During operation	Radial load P-direction (N)	784
	Thrust load A, B-direction (N)	343

• For details of Note 1 to Note 5, refer to P.182, 183.

• Dimensions of Driver, refer to P.45.

\*1 Motor specifications: □

\*2 The product that the end of driver model designation has "E" is "Position control type".  
Detail of model designation, refer to P.152.

Torque characteristics (at AC200 V of power voltage <Dotted line represents the torque at 10 % less supply voltage.>)

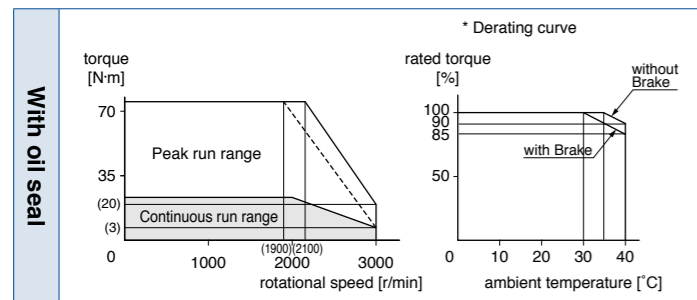

Dimensions

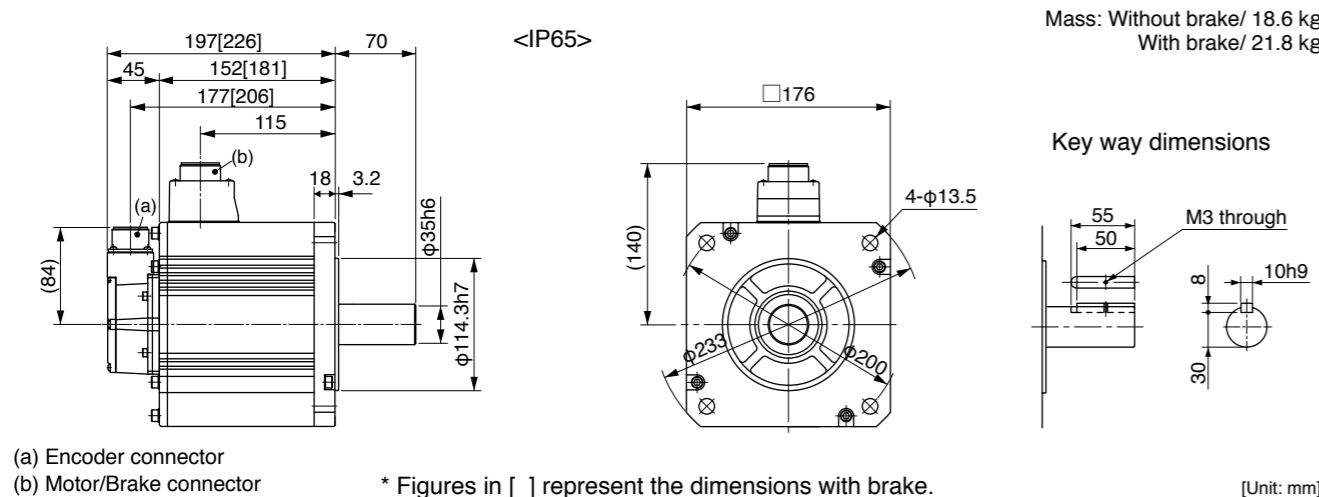

<Cautions> Reduce the moment of inertia ratio if high speed response operation is required. Dimensions are subject to change without notice. Contact us or a dealer for the latest information. Read the Instruction Manual carefully and understand all precautions and remarks before using the products. Please avoid the motor, or equipment containing the motor to be distributed to Japan, or other regions through Japan.

\* Please contact us for more information.

Specifications

		AC200 V	
Motor model *1	IP65	MGME092GC□M	MGME092SC□M
	IP67	-	-
Applicable driver *2	Model No.	A5II series MDDKT5540	-
	A5IE series	MDDKT5540E	-
Frame symbol		D-frame	
Power supply capacity (kVA)	1.8		
Rated output (W)	900		
Rated torque (N·m)	8.59		
Momentary Max. peak torque (N·m)	19.3		
Rated current (A(rms))	7.6		
Max. current (A(o-p))	24		
Regenerative brake frequency (times/min) Note1	Without option	No limit Note2	
	DV0P4284	No limit Note2	
Rated rotational speed (r/min)	1000		
Max. rotational speed (r/min)	2000		
Moment of inertia of rotor (×10 <sup>-4</sup> kg·m <sup>2</sup> )	Without brake	6.70	
	With brake	7.99	
Recommended moment of inertia ratio of the load and the rotor Note3	10 times or less		
Rotary encoder specifications Note5	20-bit Incremental	17-bit Absolute	
	Resolution per single turn	1,048,576	131,072

• **Brake specifications** (For details, refer to P.183)  
(This brake will be released when it is energized.)  
(Do not use this for braking the motor in motion.)

Static friction torque (N·m)	13.7 or more
Engaging time (ms)	100 or less
Releasing time (ms) Note4	50 or less
Exciting current (DC) (A)	0.79±10 %
Releasing voltage (DC) (V)	2 or more
Exciting voltage (DC) (V)	24±2.4

• **Permissible load** (For details, refer to P.183)

During assembly	Radial load P-direction (N)	980
	Thrust load A-direction (N)	588
	Thrust load B-direction (N)	686
During operation	Radial load P-direction (N)	686
	Thrust load A, B-direction (N)	196

• For details of Note 1 to Note 5, refer to P.182, 183.

• Dimensions of Driver, refer to P.43.

\*1 Motor specifications: □

\*2 The product that the end of driver model designation has "E" is "Position control type".  
Detail of model designation, refer to P.152.

Torque characteristics (at AC200 V of power voltage <Dotted line represents the torque at 10 % less supply voltage.>)

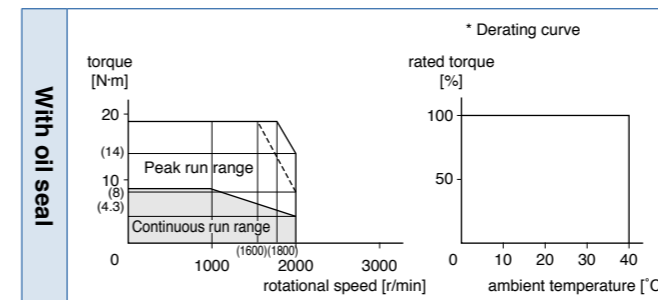

Dimensions

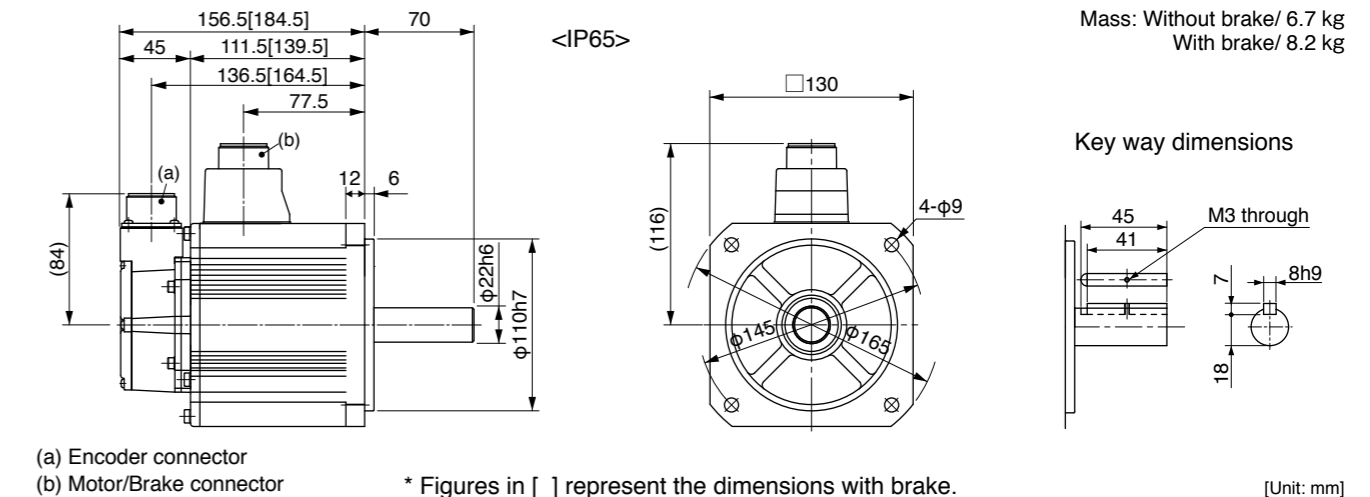

<Cautions> Reduce the moment of inertia ratio if high speed response operation is required. Dimensions are subject to change without notice. Contact us or a dealer for the latest information. Read the Instruction Manual carefully and understand all precautions and remarks before using the products. Please avoid the motor, or equipment containing the motor to be distributed to Japan, or other regions through Japan.

\* Please contact us for more information.

Specifications

		AC200 V	
Motor model *1	IP65	MGME202GC□M	MGME202SC□M
	IP67	-	-
Applicable driver *2	Model No.	A5II series MFDKTA390	-
	A5IE series	MFDKTA390E	-
Frame symbol		F-frame	
Power supply capacity (kVA)	3.8		
Rated output (W)	2000		
Rated torque (N·m)	19.1		
Momentary Max. peak torque (N·m)	47.7		
Rated current (A(rms))	17.0		
Max. current (A(o-p))	60		
Regenerative brake frequency (times/min) Note1	Without option	No limit Note2	
	DV0P4285×2	No limit Note2	
Rated rotational speed (r/min)	1000		
Max. rotational speed (r/min)	2000		
Moment of inertia of rotor (×10 <sup>-4</sup> kg·m <sup>2</sup> )	Without brake	30.3	
	With brake	31.4	
Recommended moment of inertia ratio of the load and the rotor Note3	10 times or less		
Rotary encoder specifications Note5	20-bit Incremental	17-bit Absolute	
	Resolution per single turn	1,048,576	131,072

• Brake specifications (For details, refer to P.183)

(This brake will be released when it is energized.)  
(Do not use this for braking the motor in motion.)

Static friction torque (N·m)	24.5 or more
Engaging time (ms)	80 or less
Releasing time (ms) Note4	25 or less
Exciting current (DC) (A)	1.3±10 %
Releasing voltage (DC) (V)	2 or more
Exciting voltage (DC) (V)	24±2.4

• Permissible load (For details, refer to P.183)

During assembly	Radial load P-direction (N)	1666
	Thrust load A-direction (N)	784
	Thrust load B-direction (N)	980
During operation	Radial load P-direction (N)	1176
	Thrust load A, B-direction (N)	490

• For details of Note 1 to Note 5, refer to P.182, 183.

• Dimensions of Driver, refer to P.45.

\*1 Motor specifications: □

\*2 The product that the end of driver model designation has "E" is "Position control type".  
Detail of model designation, refer to P.152.

Torque characteristics (at AC200 V of power voltage <Dotted line represents the torque at 10 % less supply voltage.>)

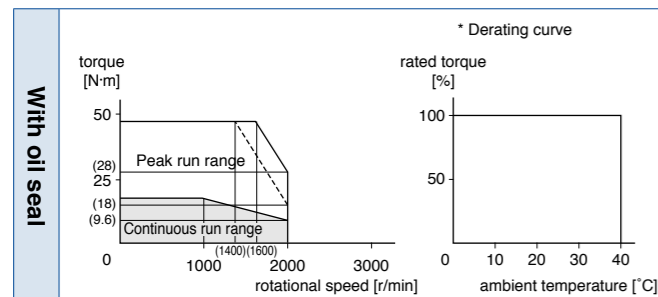

Dimensions

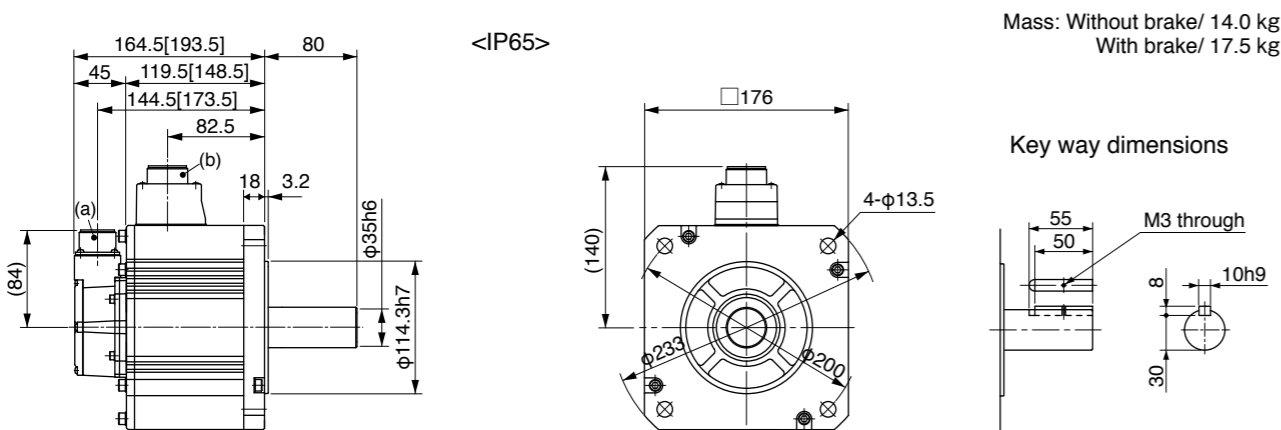

Mass: Without brake/ 14.0 kg  
With brake/ 17.5 kg

(a) Encoder connector  
(b) Motor/Brake connector

\* Figures in [ ] represent the dimensions with brake.

[Unit: mm]

<Cautions> Reduce the moment of inertia ratio if high speed response operation is required. Dimensions are subject to change without notice. Contact us or a dealer for the latest information. Read the Instruction Manual carefully and understand all precautions and remarks before using the products. Please avoid the motor, or equipment containing the motor to be distributed to Japan, or other regions through Japan.

\* Please contact us for more information.

Specifications

		AC200 V	
Motor model *1	IP65	MGME302GC□M	MGME302SC□M
	IP67	-	-
Applicable driver *2	Model No.	A5II series MFDKTB3A2	-
	A5IE series	MFDKTB3A2E	-
Frame symbol		F-frame	
Power supply capacity (kVA)	4.5		
Rated output (W)	3000		
Rated torque (N·m)	28.7		
Momentary Max. peak torque (N·m)	71.7		
Rated current (A(rms))	22.6		
Max. current (A(o-p))	80		
Regenerative brake frequency (times/min) Note1	Without option	No limit Note2	
	DV0P4285×2	No limit Note2	
Rated rotational speed (r/min)	1000		
Max. rotational speed (r/min)	2000		
Moment of inertia of rotor (×10 <sup>-4</sup> kg·m <sup>2</sup> )	Without brake	48.4	
	With brake	49.2	
Recommended moment of inertia ratio of the load and the rotor Note3	10 times or less		
Rotary encoder specifications Note5	20-bit Incremental	17-bit Absolute	
	Resolution per single turn	1,048,576	131,072

• Brake specifications (For details, refer to P.183)

(This brake will be released when it is energized.)  
(Do not use this for braking the motor in motion.)

Static friction torque (N·m)	58.8 or more
Engaging time (ms)	150 or less
Releasing time (ms) Note4	50 or less
Exciting current (DC) (A)	1.4±10 %
Releasing voltage (DC) (V)	2 or more
Exciting voltage (DC) (V)	24±2.4

• Permissible load (For details, refer to P.183)

During assembly	Radial load P-direction (N)	2058
	Thrust load A-direction (N)	980
	Thrust load B-direction (N)	1176
During operation	Radial load P-direction (N)	1470
	Thrust load A, B-direction (N)	490

• For details of Note 1 to Note 5, refer to P.182, 183.

• Dimensions of Driver, refer to P.45.

\*1 Motor specifications: □

\*2 The product that the end of driver model designation has "E" is "Position control type".  
Detail of model designation, refer to P.152.

Torque characteristics (at AC200 V of power voltage <Dotted line represents the torque at 10 % less supply voltage.>)

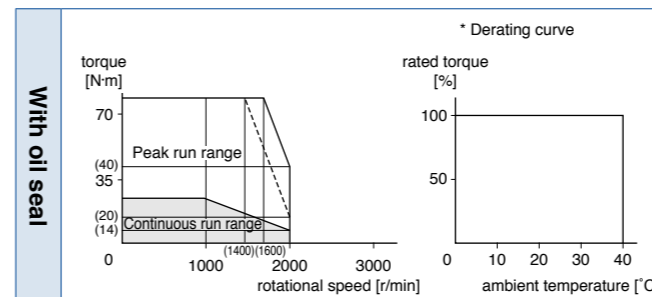

Dimensions

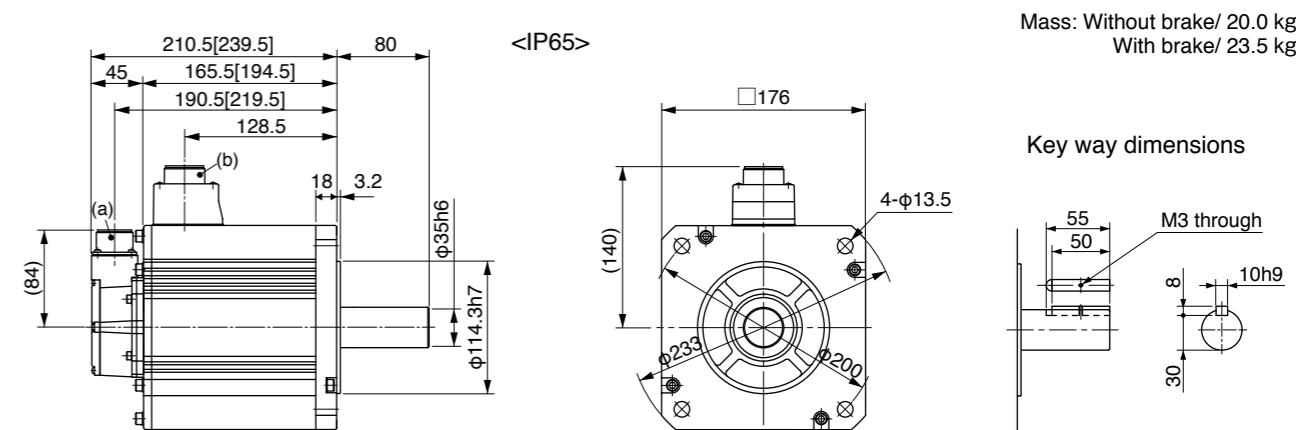

Mass: Without brake/ 20.0 kg  
With brake/ 23.5 kg

(a) Encoder connector  
(b) Motor/Brake connector

\* Figures in [ ] represent the dimensions with brake.

[Unit: mm]

<Cautions> Reduce the moment of inertia ratio if high speed response operation is required. Dimensions are subject to change without notice. Contact us or a dealer for the latest information. Read the Instruction Manual carefully and understand all precautions and remarks before using the products. Please avoid the motor, or equipment containing the motor to be distributed to Japan, or other regions through Japan.

\* Please contact us for more information.

Specifications

		AC200 V	
Motor model *1	IP65	MHMJ022G1□	MHMJ022S1□
	IP67	-	-
Applicable driver *2	Model No.	A5I series	<b>MADKT1507</b>
	A5IE series	<b>MADKT1507E</b>	-
Frame symbol		A-frame	
Power supply capacity (kVA)	0.5		
Rated output (W)	200		
Rated torque (N·m)	0.64		
Momentary Max. peak torque (N·m)	1.91		
Rated current (A(rms))	1.6		
Max. current (A(o-p))	6.9		
Regenerative brake frequency (times/min) Note)1	Without option	No limit	Note)2
	DV0P4283	No limit	Note)2
Rated rotational speed (r/min)	3000		
Max. rotational speed (r/min)	5000		
Moment of inertia of rotor (×10 <sup>-4</sup> kg·m <sup>2</sup> )	Without brake	0.42	
	With brake	0.45	
Recommended moment of inertia ratio of the load and the rotor Note)3	30 times or less		
Rotary encoder specifications Note)5	20-bit Incremental	17-bit Absolute	
	Resolution per single turn	1,048,576	131,072

• **Brake specifications** (For details, refer to P.183)  
 (This brake will be released when it is energized.)  
 (Do not use this for braking the motor in motion.)

Static friction torque (N·m)	1.27 or more
Engaging time (ms)	50 or less
Releasing time (ms) Note)4	15 or less
Exciting current (DC) (A)	0.36
Releasing voltage (DC) (V)	1 or more
Exciting voltage (DC) (V)	24±1.2

• **Permissible load** (For details, refer to P.183)

During assembly	Radial load P-direction (N)	392
	Thrust load A-direction (N)	147
	Thrust load B-direction (N)	196
During operation	Radial load P-direction (N)	245
	Thrust load A, B-direction (N)	98

• For details of Note 1 to Note 5, refer to P.182, 183.

• Dimensions of Driver, refer to P.42.

\*1 Motor specifications: □

\*2 The product that the end of driver model designation has "E" is "Position control type".  
 Detail of model designation, refer to P.152.

Torque characteristics (at AC200 V of power voltage <Dotted line represents the torque at 10% less supply voltage.>)

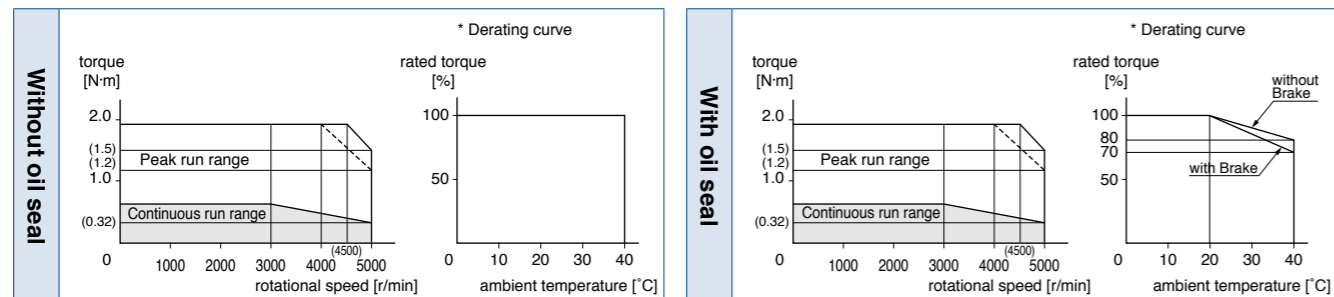

Dimensions

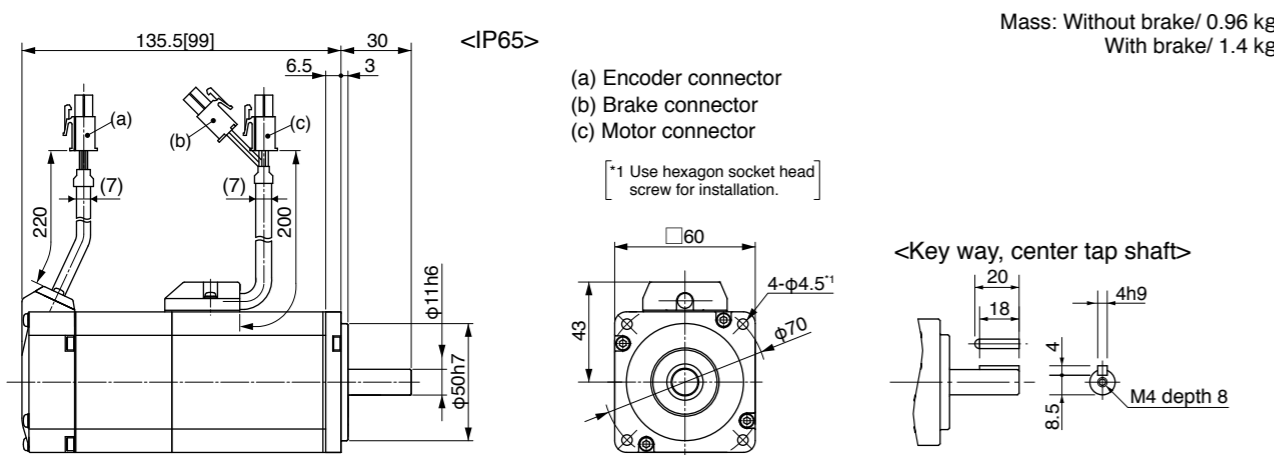

\* Figures in [ ] represent the dimensions without brake.

[Unit: mm]

<Cautions> Reduce the moment of inertia ratio if high speed response operation is required. Dimensions are subject to change without notice. Contact us or a dealer for the latest information. Read the Instruction Manual carefully and understand all precautions and remarks before using the products. Please avoid the motor, or equipment containing the motor to be distributed to Japan, or other regions through Japan.

\* Please contact us for more information.

Specifications

		AC200 V	
Motor model *1	IP65	MHMJ042G1□	MHMJ042S1□
	IP67	-	-
Applicable driver *2	Model No.	A5I series	<b>MBDKT2510</b>
	A5IE series	<b>MBDKT2510E</b>	-
Frame symbol		B-frame	
Power supply capacity (kVA)	0.9		
Rated output (W)	400		
Rated torque (N·m)	1.3		
Momentary Max. peak torque (N·m)	3.8		
Rated current (A(rms))	2.6		
Max. current (A(o-p))	11.0		
Regenerative brake frequency (times/min) Note)1	Without option	No limit	Note)2
	DV0P4283	No limit	Note)2
Rated rotational speed (r/min)	3000		
Max. rotational speed (r/min)	5000		
Moment of inertia of rotor (×10 <sup>-4</sup> kg·m <sup>2</sup> )	Without brake	0.67	
	With brake	0.70	
Recommended moment of inertia ratio of the load and the rotor Note)3	30 times or less		
Rotary encoder specifications Note)5	20-bit Incremental	17-bit Absolute	
	Resolution per single turn	1,048,576	131,072

• **Brake specifications** (For details, refer to P.183)  
 (This brake will be released when it is energized.)  
 (Do not use this for braking the motor in motion.)

Static friction torque (N·m)	1.27 or more
Engaging time (ms)	50 or less
Releasing time (ms) Note)4	15 or less
Exciting current (DC) (A)	0.36
Releasing voltage (DC) (V)	1 or more
Exciting voltage (DC) (V)	24±1.2

• **Permissible load** (For details, refer to P.183)

During assembly	Radial load P-direction (N)	392
	Thrust load A-direction (N)	147
	Thrust load B-direction (N)	196
During operation	Radial load P-direction (N)	245
	Thrust load A, B-direction (N)	98

• For details of Note 1 to Note 5, refer to P.182, 183.

• Dimensions of Driver, refer to P.42.

\*1 Motor specifications: □

\*2 The product that the end of driver model designation has "E" is "Position control type".  
 Detail of model designation, refer to P.152.

Torque characteristics (at AC200 V of power voltage <Dotted line represents the torque at 10% less supply voltage.>)

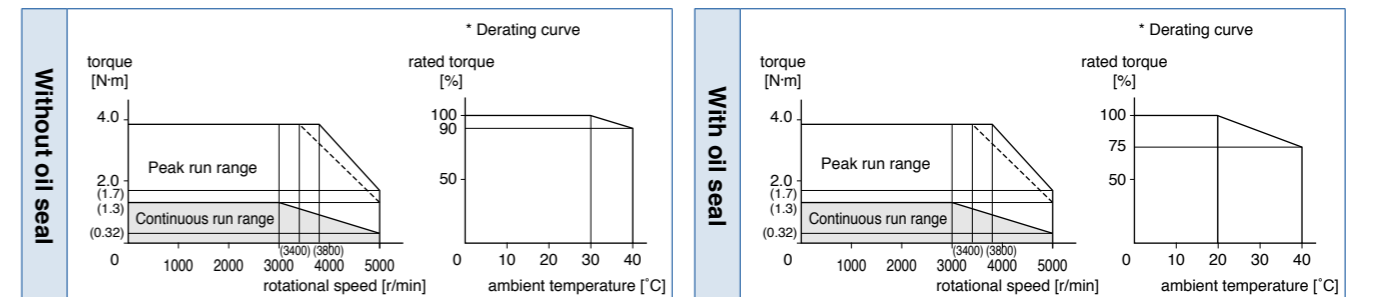

Dimensions

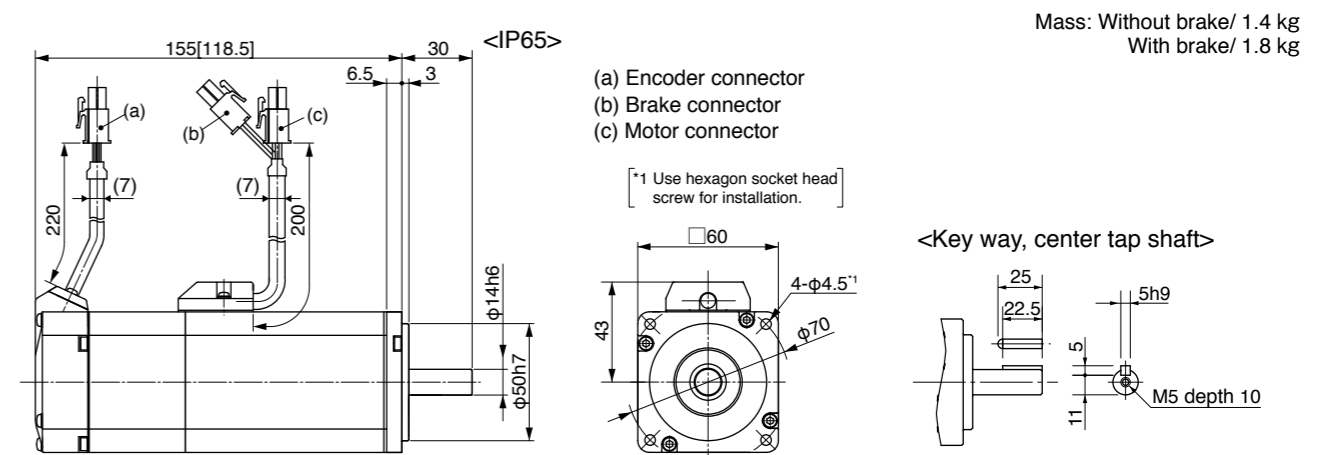

\* Figures in [ ] represent the dimensions without brake.

[Unit: mm]

<Cautions> Reduce the moment of inertia ratio if high speed response operation is required. Dimensions are subject to change without notice. Contact us or a dealer for the latest information. Read the Instruction Manual carefully and understand all precautions and remarks before using the products. Please avoid the motor, or equipment containing the motor to be distributed to Japan, or other regions through Japan.



\* Please contact us for more information.

Specifications

		AC200 V	
Motor model *1	IP65	MHMJ082G1□	MHMJ082S1□
	IP67	-	-
Applicable driver *2	Model No.	A5II series MCDKT3520	-
	A5IE series	MCDKT3520E	-
Frame symbol		C-frame	
Power supply capacity (kVA)		1.3	
Rated output (W)		750	
Rated torque (N·m)		2.4	
Momentary Max. peak torque (N·m)		7.1	
Rated current (A(rms))		4.0	
Max. current (A(o-p))		17.0	
Regenerative brake frequency (times/min) Note)1	Without option	No limit Note)2	
	DV0P4283	No limit Note)2	
Rated rotational speed (r/min)		3000	
Max. rotational speed (r/min)		4500	
Moment of inertia of rotor ( $\times 10^{-4}$ kg·m <sup>2</sup> )	Without brake	1.51	
	With brake	1.61	
Recommended moment of inertia ratio of the load and the rotor Note)3		20 times or less	
Rotary encoder specifications Note)5	20-bit Incremental		17-bit Absolute
	Resolution per single turn	1,048,576	131,072

• **Brake specifications** (For details, refer to P.183)  
 (This brake will be released when it is energized.)  
 (Do not use this for braking the motor in motion.)

Static friction torque (N·m)	2.45 or more
Engaging time (ms)	70 or less
Releasing time (ms) Note)4	20 or less
Exciting current (DC) (A)	0.42
Releasing voltage (DC) (V)	1 or more
Exciting voltage (DC) (V)	24±1.2

• **Permissible load** (For details, refer to P.183)

During assembly	Radial load P-direction (N)	686
	Thrust load A-direction (N)	294
	Thrust load B-direction (N)	392
During operation	Radial load P-direction (N)	392
	Thrust load A, B-direction (N)	147

• For details of Note 1 to Note 5, refer to P.182, 183.  
 • Dimensions of Driver, refer to P.43.

\*1 Motor specifications: □

\*2 The product that the end of driver model designation has "E" is "Position control type".  
 Detail of model designation, refer to P.152.

Torque characteristics (at AC200 V of power voltage <Dotted line represents the torque at 10 % less supply voltage.>)

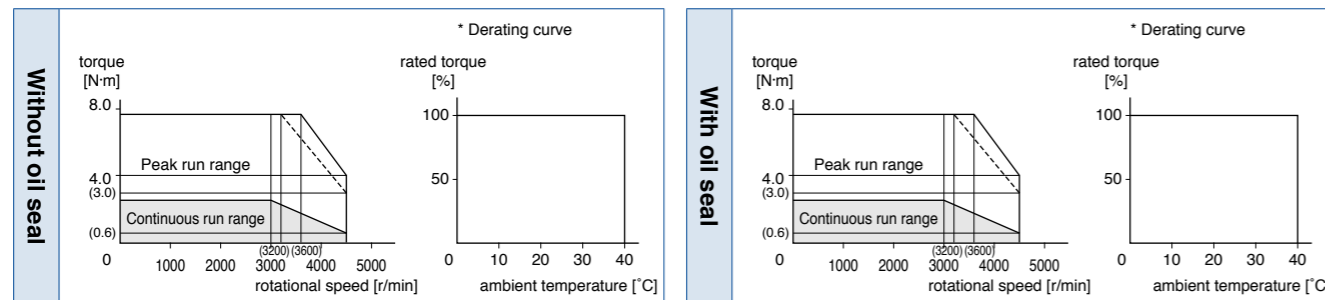

Dimensions

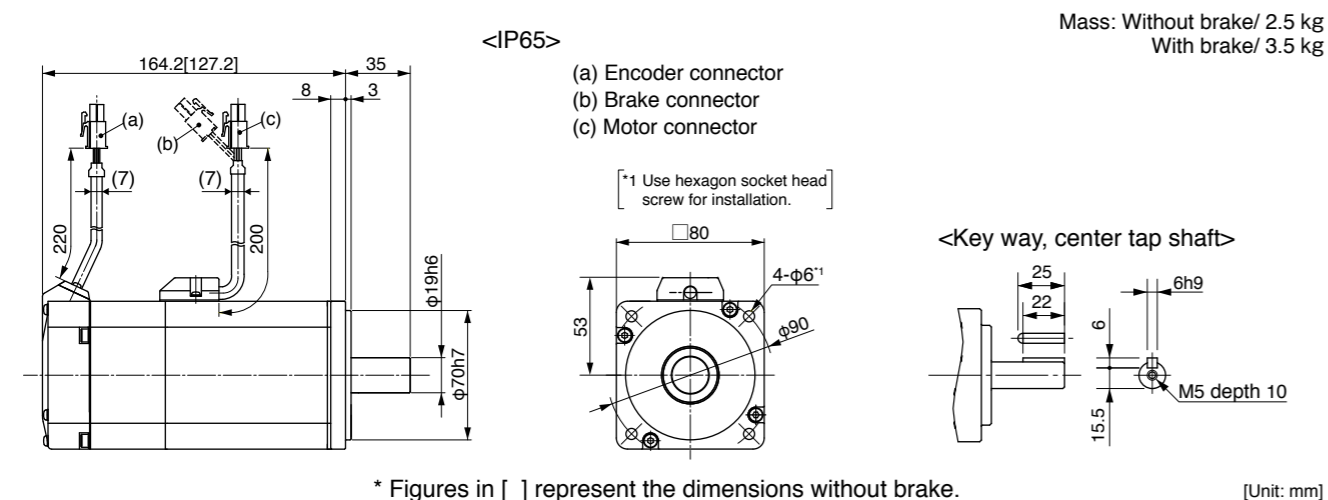

\* Figures in [ ] represent the dimensions without brake. [Unit: mm]  
**<Cautions>** Reduce the moment of inertia ratio if high speed response operation is required. Dimensions are subject to change without notice. Contact us or a dealer for the latest information. Read the Instruction Manual carefully and understand all precautions and remarks before using the products. Please avoid the motor, or equipment containing the motor to be distributed to Japan, or other regions through Japan.

\* Please contact us for more information.

Specifications

		AC200 V	
Motor model *1	IP65	MHME102GC□M	MHME102SC□M
	IP67	-	-
Applicable driver *2	Model No.	A5II series MDDKT3530	-
	A5IE series	MDDKT3530E	-
Frame symbol		D-frame	
Power supply capacity (kVA)		1.8	
Rated output (W)		1000	
Rated torque (N·m)		4.77	
Momentary Max. peak torque (N·m)		14.3	
Rated current (A(rms))		5.7	
Max. current (A(o-p))		24	
Regenerative brake frequency (times/min) Note)1	Without option	83	
	DV0P4284	No limit Note)2	
Rated rotational speed (r/min)		2000	
Max. rotational speed (r/min)		3000	
Moment of inertia of rotor ( $\times 10^{-4}$ kg·m <sup>2</sup> )	Without brake	24.7	
	With brake	26.0	
Recommended moment of inertia ratio of the load and the rotor Note)3		5 times or less	
Rotary encoder specifications Note)5	20-bit Incremental		17-bit Absolute
	Resolution per single turn	1,048,576	131,072

• **Brake specifications** (For details, refer to P.183)  
 (This brake will be released when it is energized.)  
 (Do not use this for braking the motor in motion.)

Static friction torque (N·m)	4.9 or more
Engaging time (ms)	80 or less
Releasing time (ms) Note)4	70 or less
Exciting current (DC) (A)	0.59±10 %
Releasing voltage (DC) (V)	2 or more
Exciting voltage (DC) (V)	24±2.4

• **Permissible load** (For details, refer to P.183)

During assembly	Radial load P-direction (N)	980
	Thrust load A-direction (N)	588
	Thrust load B-direction (N)	686
During operation	Radial load P-direction (N)	490
	Thrust load A, B-direction (N)	196

• For details of Note 1 to Note 5, refer to P.182, 183.  
 • Dimensions of Driver, refer to P.43.

\*1 Motor specifications: □

\*2 The product that the end of driver model designation has "E" is "Position control type".  
 Detail of model designation, refer to P.152.

Torque characteristics (at AC200 V of power voltage <Dotted line represents the torque at 10 % less supply voltage.>)

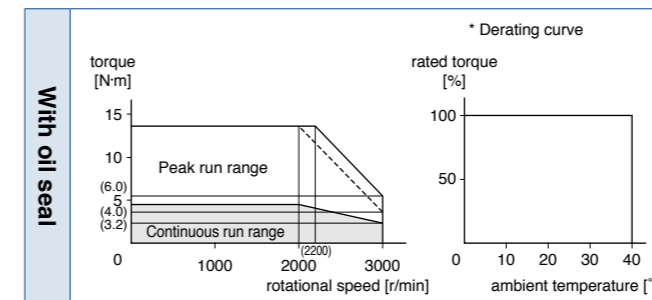

Dimensions

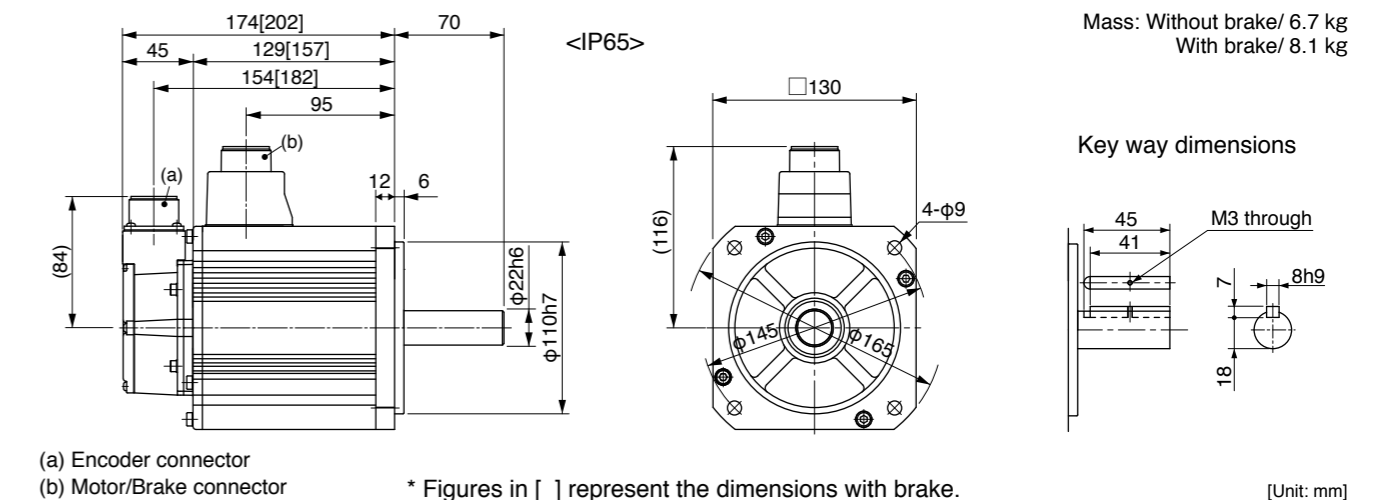

\* Figures in [ ] represent the dimensions with brake. [Unit: mm]  
**<Cautions>** Reduce the moment of inertia ratio if high speed response operation is required. Dimensions are subject to change without notice. Contact us or a dealer for the latest information. Read the Instruction Manual carefully and understand all precautions and remarks before using the products. Please avoid the motor, or equipment containing the motor to be distributed to Japan, or other regions through Japan.

\* Please contact us for more information.

Specifications

		AC200 V	
Motor model *1	IP65	MHME152GC□M	MHME152SC□M
	IP67	-	-
Applicable driver *2	Model No.	A5I series	MDDKT5540
	A5IE series	MDDKT5540E	-
Frame symbol		D-frame	
Power supply capacity (kVA)	2.3		
Rated output (W)	1500		
Rated torque (N·m)	7.16		
Momentary Max. peak torque (N·m)	21.5		
Rated current (A(rms))	9.4		
Max. current (A(o-p))	40		
Regenerative brake frequency (times/min) Note1	Without option	22	
	DV0P4284	130	
Rated rotational speed (r/min)	2000		
Max. rotational speed (r/min)	3000		
Moment of inertia of rotor (×10 <sup>-4</sup> kg·m <sup>2</sup> )	Without brake	37.1	
	With brake	38.4	
Recommended moment of inertia ratio of the load and the rotor Note3	5 times or less		
Rotary encoder specifications Note5	20-bit Incremental	17-bit Absolute	
	Resolution per single turn	1,048,576	131,072

• Brake specifications (For details, refer to P.183)

(This brake will be released when it is energized.)  
(Do not use this for braking the motor in motion.)

Static friction torque (N·m)	13.7 or more
Engaging time (ms)	100 or less
Releasing time (ms) Note4	50 or less
Exciting current (DC) (A)	0.79±10 %
Releasing voltage (DC) (V)	2 or more
Exciting voltage (DC) (V)	24±2.4

• Permissible load (For details, refer to P.183)

During assembly	Radial load P-direction (N)	980
	Thrust load A-direction (N)	588
	Thrust load B-direction (N)	686
During operation	Radial load P-direction (N)	490
	Thrust load A, B-direction (N)	196

• For details of Note 1 to Note 5, refer to P.182, 183.

• Dimensions of Driver, refer to P.43.

\*1 Motor specifications: □

\*2 The product that the end of driver model designation has "E" is "Position control type".  
Detail of model designation, refer to P.152.

Torque characteristics (at AC200 V of power voltage <Dotted line represents the torque at 10 % less supply voltage.>)

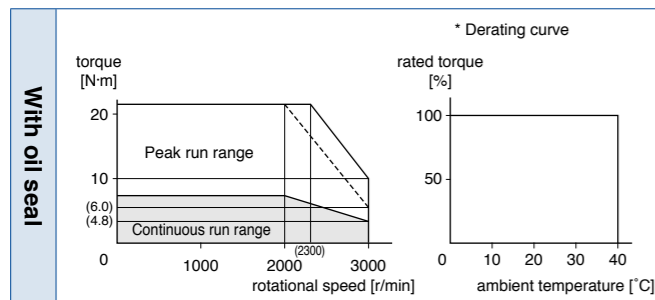

Dimensions

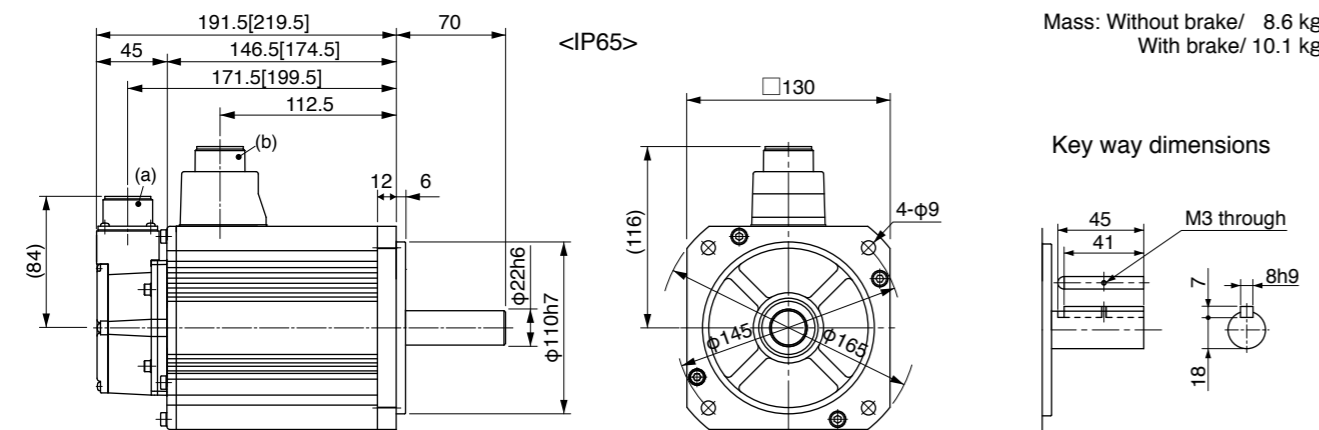

Mass: Without brake/ 8.6 kg  
With brake/ 10.1 kg

Key way dimensions

(a) Encoder connector  
(b) Motor/Brake connector

\* Figures in [ ] represent the dimensions with brake.

[Unit: mm]

<Cautions> Reduce the moment of inertia ratio if high speed response operation is required.  
Dimensions are subject to change without notice. Contact us or a dealer for the latest information.  
Read the Instruction Manual carefully and understand all precautions and remarks before using the products.  
Please avoid the motor, or equipment containing the motor to be distributed to Japan, or other regions through Japan.

\* Please contact us for more information.

Specifications

		AC200 V	
Motor model *1	IP65	MHME202GC□M	MHME202SC□M
	IP67	-	-
Applicable driver *2	Model No.	A5I series	MEDKT7364
	A5IE series	MEDKT7364E	-
Frame symbol		E-frame	
Power supply capacity (kVA)	3.3		
Rated output (W)	2000		
Rated torque (N·m)	9.55		
Momentary Max. peak torque (N·m)	28.6		
Rated current (A(rms))	11.1		
Max. current (A(o-p))	47		
Regenerative brake frequency (times/min) Note1	Without option	45	
	DV0P4285	142	
Rated rotational speed (r/min)	2000		
Max. rotational speed (r/min)	3000		
Moment of inertia of rotor (×10 <sup>-4</sup> kg·m <sup>2</sup> )	Without brake	57.8	
	With brake	59.6	
Recommended moment of inertia ratio of the load and the rotor Note3	5 times or less		
Rotary encoder specifications Note5	20-bit Incremental	17-bit Absolute	
	Resolution per single turn	1,048,576	131,072

• Brake specifications (For details, refer to P.183)

(This brake will be released when it is energized.)  
(Do not use this for braking the motor in motion.)

Static friction torque (N·m)	24.5 or more
Engaging time (ms)	80 or less
Releasing time (ms) Note4	25 or less
Exciting current (DC) (A)	1.3±10 %
Releasing voltage (DC) (V)	2 or more
Exciting voltage (DC) (V)	24±2.4

• Permissible load (For details, refer to P.183)

During assembly	Radial load P-direction (N)	1666
	Thrust load A-direction (N)	784
	Thrust load B-direction (N)	980
During operation	Radial load P-direction (N)	784
	Thrust load A, B-direction (N)	343

• For details of Note 1 to Note 5, refer to P.182, 183.

• Dimensions of Driver, refer to P.43.

\*1 Motor specifications: □

\*2 The product that the end of driver model designation has "E" is "Position control type".  
Detail of model designation, refer to P.152.

Torque characteristics (at AC200 V of power voltage <Dotted line represents the torque at 10 % less supply voltage.>)

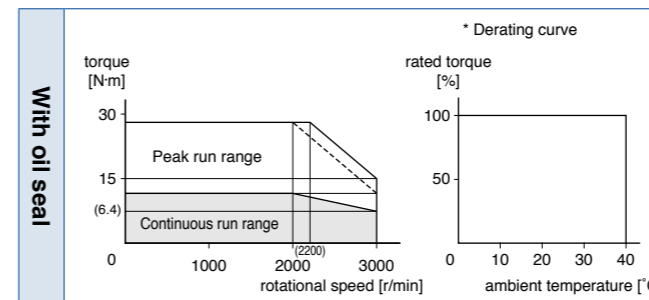

Dimensions

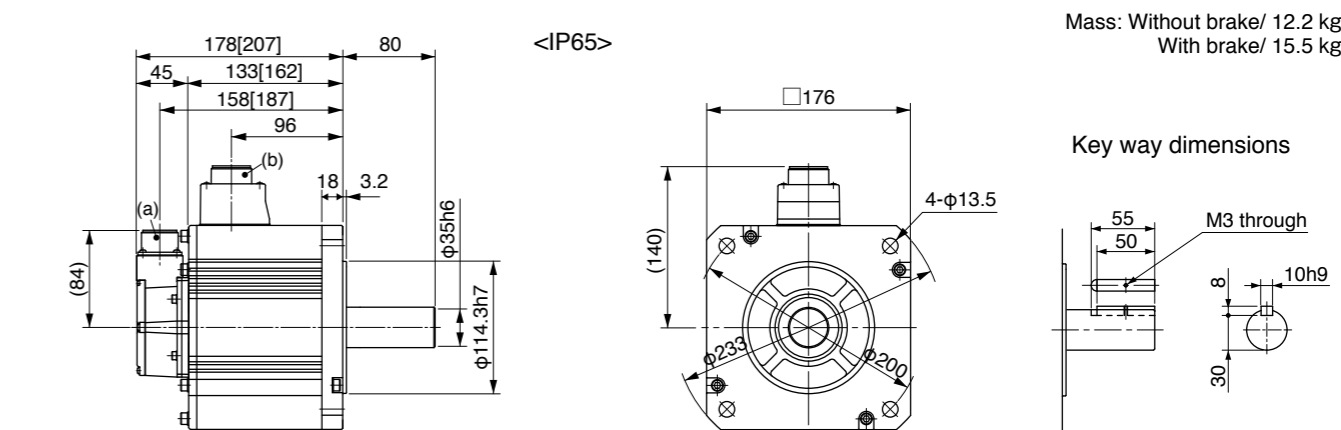

Mass: Without brake/ 12.2 kg  
With brake/ 15.5 kg

Key way dimensions

(a) Encoder connector  
(b) Motor/Brake connector

\* Figures in [ ] represent the dimensions with brake.

[Unit: mm]

<Cautions> Reduce the moment of inertia ratio if high speed response operation is required.  
Dimensions are subject to change without notice. Contact us or a dealer for the latest information.  
Read the Instruction Manual carefully and understand all precautions and remarks before using the products.  
Please avoid the motor, or equipment containing the motor to be distributed to Japan, or other regions through Japan.

\* Please contact us for more information.

Specifications

		AC200 V	
Motor model <sup>*1</sup>	IP65	MHME302GC□M	MHME302SC□M
	IP67	-	-
Applicable driver <sup>*2</sup>	Model No.	A5I series	MFDKTA390
		A5IE series	MFDKTA390E
	Frame symbol	F-frame	
Power supply capacity (kVA)	4.5		
Rated output (W)	3000		
Rated torque (N·m)	14.3		
Momentary Max. peak torque (N·m)	43.0		
Rated current (A(rms))	16.0		
Max. current (A(o-p))	68		
Regenerative brake frequency (times/min) <sup>Note1</sup>	Without option	19	
	DV0P4285×2	142	
Rated rotational speed (r/min)	2000		
Max. rotational speed (r/min)	3000		
Moment of inertia of rotor (×10 <sup>-4</sup> kg·m <sup>2</sup> )	Without brake	90.5	
	With brake	92.1	
Recommended moment of inertia ratio of the load and the rotor <sup>Note3</sup>	5 times or less		
Rotary encoder specifications <sup>Note5</sup>	20-bit Incremental	17-bit Absolute	
	Resolution per single turn	1,048,576	131,072

• Brake specifications (For details, refer to P.183)

(This brake will be released when it is energized.)  
(Do not use this for braking the motor in motion.)

Static friction torque (N·m)	24.5 or more
Engaging time (ms)	80 or less
Releasing time (ms) <sup>Note4</sup>	25 or less
Exciting current (DC) (A)	1.3±10 %
Releasing voltage (DC) (V)	2 or more
Exciting voltage (DC) (V)	24±2.4

• Permissible load (For details, refer to P.183)

During assembly	Radial load P-direction (N)	1666
	Thrust load A-direction (N)	784
	Thrust load B-direction (N)	980
During operation	Radial load P-direction (N)	784
	Thrust load A, B-direction (N)	343

• For details of Note 1 to Note 5, refer to P.182, 183.

• Dimensions of Driver, refer to P.45.

\*1 Motor specifications: □

\*2 The product that the end of driver model designation has "E" is "Position control type".  
Detail of model designation, refer to P.152.

Torque characteristics (at AC200 V of power voltage <Dotted line represents the torque at 10 % less supply voltage.>)

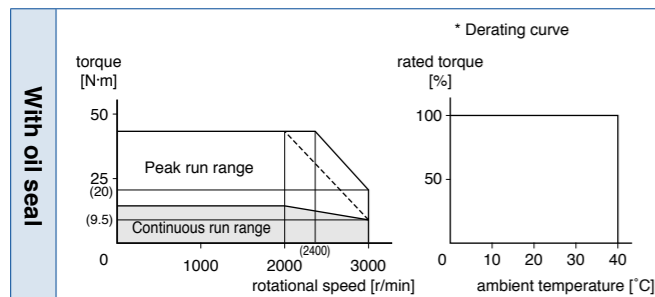

Dimensions

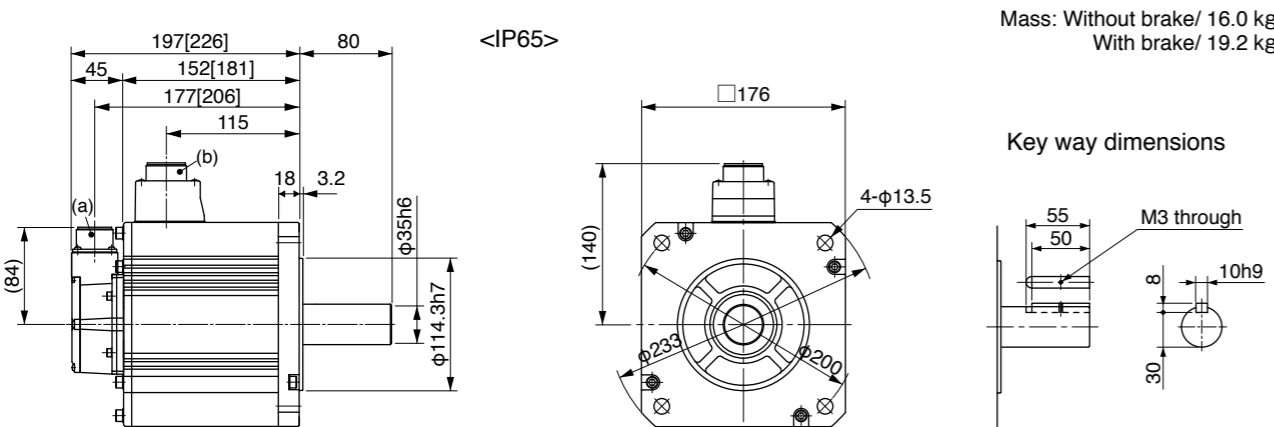

(a) Encoder connector  
(b) Motor/Brake connector

\* Figures in [ ] represent the dimensions with brake.

[Unit: mm]

<Cautions> Reduce the moment of inertia ratio if high speed response operation is required. Dimensions are subject to change without notice. Contact us or a dealer for the latest information. Read the Instruction Manual carefully and understand all precautions and remarks before using the products. Please avoid the motor, or equipment containing the motor to be distributed to Japan, or other regions through Japan.

\* Please contact us for more information.

Specifications

		AC200 V	
Motor model <sup>*1</sup>	IP65	MHME402GC□M	MHME402SC□M
	IP67	-	-
Applicable driver <sup>*2</sup>	Model No.	A5I series	MFDKTB3A2
		A5IE series	MFDKTB3A2E
	Frame symbol	F-frame	
Power supply capacity (kVA)	6.0		
Rated output (W)	4000		
Rated torque (N·m)	19.1		
Momentary Max. peak torque (N·m)	57.3		
Rated current (A(rms))	21.0		
Max. current (A(o-p))	89		
Regenerative brake frequency (times/min) <sup>Note1</sup>	Without option	17	
	DV0P4285×2	125	
Rated rotational speed (r/min)	2000		
Max. rotational speed (r/min)	3000		
Moment of inertia of rotor (×10 <sup>-4</sup> kg·m <sup>2</sup> )	Without brake	112	
	With brake	114	
Recommended moment of inertia ratio of the load and the rotor <sup>Note3</sup>	5 times or less		
Rotary encoder specifications <sup>Note5</sup>	20-bit Incremental	17-bit Absolute	
	Resolution per single turn	1,048,576	131,072

• Brake specifications (For details, refer to P.183)

(This brake will be released when it is energized.)  
(Do not use this for braking the motor in motion.)

Static friction torque (N·m)	24.5 or more
Engaging time (ms)	80 or less
Releasing time (ms) <sup>Note4</sup>	25 or less
Exciting current (DC) (A)	1.3±10 %
Releasing voltage (DC) (V)	2 or more
Exciting voltage (DC) (V)	24±2.4

• Permissible load (For details, refer to P.183)

During assembly	Radial load P-direction (N)	1666
	Thrust load A-direction (N)	784
	Thrust load B-direction (N)	980
During operation	Radial load P-direction (N)	784
	Thrust load A, B-direction (N)	343

• For details of Note 1 to Note 5, refer to P.182, 183.

• Dimensions of Driver, refer to P.45.

\*1 Motor specifications: □

\*2 The product that the end of driver model designation has "E" is "Position control type".  
Detail of model designation, refer to P.152.

Torque characteristics (at AC200 V of power voltage <Dotted line represents the torque at 10 % less supply voltage.>)

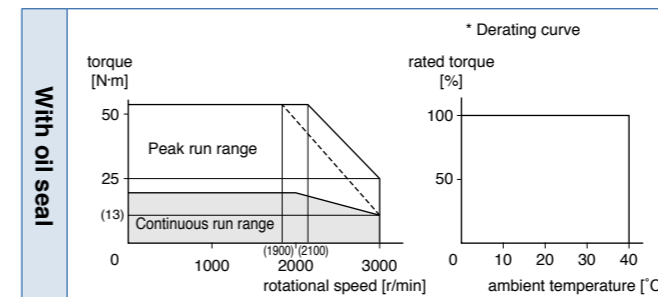

Dimensions

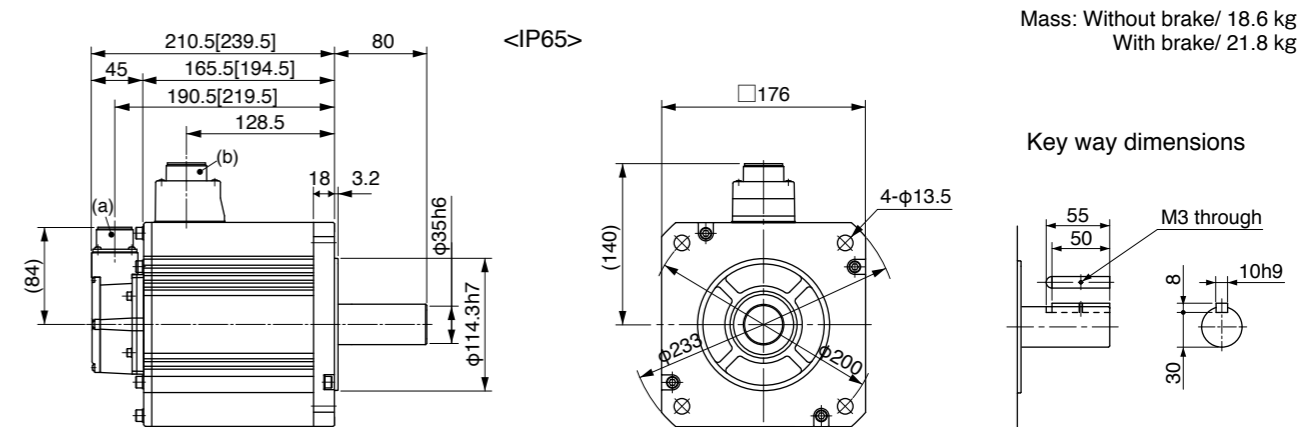

(a) Encoder connector  
(b) Motor/Brake connector

\* Figures in [ ] represent the dimensions with brake.

[Unit: mm]

<Cautions> Reduce the moment of inertia ratio if high speed response operation is required. Dimensions are subject to change without notice. Contact us or a dealer for the latest information. Read the Instruction Manual carefully and understand all precautions and remarks before using the products. Please avoid the motor, or equipment containing the motor to be distributed to Japan, or other regions through Japan.

\* Please contact us for more information.

Specifications

		AC200 V	
Motor model *1	IP65	MHME502GC□M	MHME502SC□M
	IP67	-	-
Applicable driver *2	Model No.	A5II series	MFDKTB3A2
		A5IE series	MFDKTB3A2E
	Frame symbol	F-frame	
Power supply capacity (kVA)	7.5		
Rated output (W)	5000		
Rated torque (N·m)	23.9		
Momentary Max. peak torque (N·m)	71.6		
Rated current (A(rms))	25.9		
Max. current (A(o-p))	110		
Regenerative brake frequency (times/min) Note1	Without option	10	
	DV0P4285×2	76	
Rated rotational speed (r/min)	2000		
Max. rotational speed (r/min)	3000		
Moment of inertia of rotor (×10 <sup>-4</sup> kg·m <sup>2</sup> )	Without brake	162	
	With brake	164	
Recommended moment of inertia ratio of the load and the rotor Note3	5 times or less		
Rotary encoder specifications Note5	20-bit Incremental	17-bit Absolute	
	Resolution per single turn	1,048,576	131,072

• **Brake specifications** (For details, refer to P.183)  
 (This brake will be released when it is energized.)  
 (Do not use this for braking the motor in motion.)

Static friction torque (N·m)	24.5 or more
Engaging time (ms)	80 or less
Releasing time (ms) Note4	25 or less
Exciting current (DC) (A)	1.3±10 %
Releasing voltage (DC) (V)	2 or more
Exciting voltage (DC) (V)	24±2.4

• **Permissible load** (For details, refer to P.183)

During assembly	Radial load P-direction (N)	1666
	Thrust load A-direction (N)	784
	Thrust load B-direction (N)	980
During operation	Radial load P-direction (N)	784
	Thrust load A, B-direction (N)	343

• For details of Note 1 to Note 5, refer to P.182, 183.

• Dimensions of Driver, refer to P.45.

\*1 Motor specifications: □

\*2 The product that the end of driver model designation has "E" is "Position control type".  
 Detail of model designation, refer to P.152.

Torque characteristics (at AC200 V of power voltage <Dotted line represents the torque at 10 % less supply voltage.>)

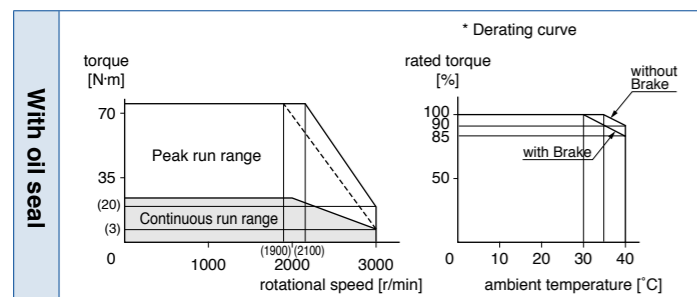

Dimensions

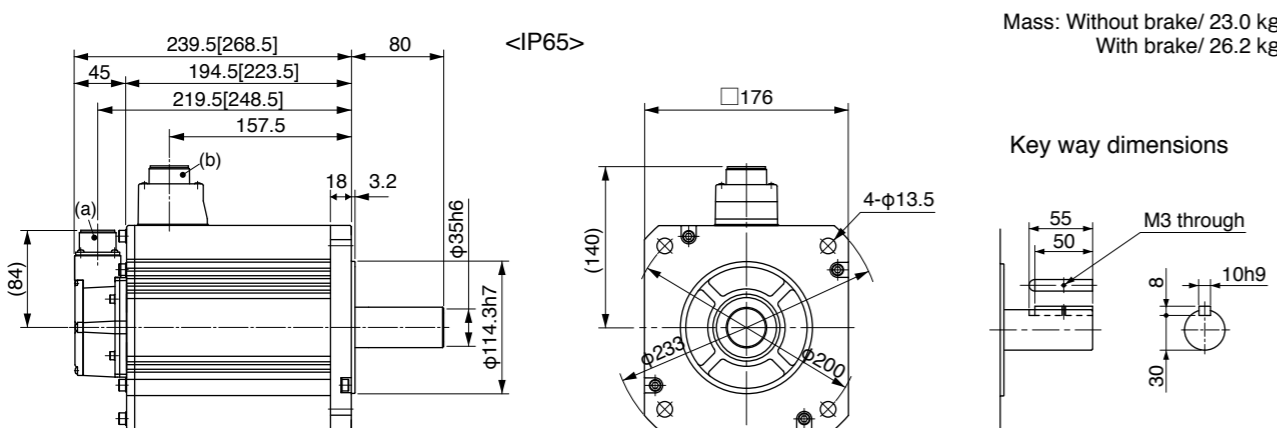

Mass: Without brake/ 23.0 kg  
 With brake/ 26.2 kg

Key way dimensions

(a) Encoder connector  
 (b) Motor/Brake connector

\* Figures in [ ] represent the dimensions with brake.

[Unit: mm]

<Cautions> Reduce the moment of inertia ratio if high speed response operation is required.  
 Dimensions are subject to change without notice. Contact us or a dealer for the latest information.  
 Read the Instruction Manual carefully and understand all precautions and remarks before using the products.  
 Please avoid the motor, or equipment containing the motor to be distributed to Japan, or other regions through Japan.

Environmental Conditions

Item	Conditions	
Ambient temperature *1	0 °C to 40 °C (free from freezing)	
Ambient humidity	20 % to 85 % RH (free from condensation)	
Storage temperature *2	-20 °C to 65 °C (Max.temperature guarantee: 80 °C for 72 hours free from condensation <sup>5</sup> )	
Storage humidity	20 % to 85 % RH (free from condensation <sup>5</sup> )	
Vibration	Motor only	50 W to 5.0 kW : Lower than 49 m/s <sup>2</sup> (5 G) at running, 24.5 m/s <sup>2</sup> (2.5 G) at stall 6.0 kW to 15.0 kW : Lower than 24.5 m/s <sup>2</sup> (2.5 G) at running, 24.5 m/s <sup>2</sup> (2.5 G) at stall
Impact	Motor only	Lower than 98 m/s <sup>2</sup> (10 G)
Enclosure rating (Motor only)	IP65 *3	MSMD, MHMD, MSMJ, MHMJ (except rotating portion of output shaft and readwire end.) M * ME (IP65 motor: 0.9 kW or more) (except rotating portion of output shaft and connecting pin part of the motor connector and the encoder connector)
	IP67 *3*4	M * ME IP67 motor (except rotating portion of output shaft and connecting pin part of the motor connector and the encoder connector)
Altitude	Lower than 1000 m	

\*1 Ambient temperature to be measured at 5 cm away from the motor.

\*2 Permissible temperature for short duration such as transportation.

\*3 These motors conform to the test conditions specified in EN standards (EN60529, EN60034-5). Do not use these motors in application where water proof performance is required such as continuous wash-down operation.

\*4 This condition is applied when the connector mounting screw are tightened to the recommended tightening torque.

\*5 Air containing water vapor will become saturated with water vapor as the temperature falls, causing dew.

<Note>

Initial setup of rotational direction:  
 positive = CCW and negative = CW.  
 Pay an extra attention.

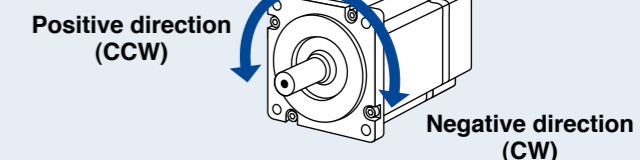

Notes on [Motor specification] page

Note) 1. [At AC100 V of power voltage]

Regenerative brake frequency represents the frequency of the motor's stops from the rated speed with deceleration without load.

- If the load is connected, frequency will be defines as 1/(m+1), where m=load moment of inertia/ rotor moment of inertia.
- When the motor speed exceeds the rated speed, regenerative brake frequency is in inverse proportion to the square of (running speed/rated speed).
- Power supply voltage is AC115 V (at 100 V of the main voltage).  
 If the supply voltage fluctuates, frequency is in inverse proportion to the square of (Running supply voltage/115) relative to the value in the table.
- When regeneration occurs continuously such cases as running speed frequently changes or vertical feeding, consult us or a dealer.

[At AC200 V of power voltage]

Regenerative brake frequency represents the frequency of the motor's stops from the rated speed with deceleration without load.

- If the load is connected, frequency will be defines as 1/(m+1), where m=load moment of inertia/ rotor moment of inertia.
- When the motor speed exceeds the rated speed, regenerative brake frequency is in inverse proportion to the square of (running speed/rated speed).
- Power supply voltage is AC230 V (at 200 V of the main voltage).  
 If the supply voltage fluctuates, frequency is in inverse proportion to the square of (Running supply voltage/230) relative to the value in the table.
- When regeneration occurs continuously such cases as running speed frequently changes or vertical feeding, consult us or a dealer.

[At AC400 V of power voltage]

Regenerative brake frequency represents the frequency of the motor's stops from the rated speed with deceleration without load.

- If the load is connected, frequency will be defines as  $1/(m+1)$ , where m=load moment of inertia/rotor moment of inertia.
- When the motor speed exceeds the rated speed, regenerative brake frequency is in inverse proportion to the square of (running speed/rated speed).
- Power supply voltage is AC460 V (at 400 V of the main voltage).  
If the supply voltage fluctuates, frequency is in inverse proportion to the square of (Running supply voltage/460) relative to the value in the table.
- When regeneration occurs continuously such cases as running speed frequently changes or vertical feeding, consult us or a dealer.

Note) 2. If the effective torque is within the rated torque, there is no limit in generative brake.

Note) 3. Consult us or a dealer if the load moment of inertia exceeds the specified value.

Note) 4. Releasing time values represent the ones with DC-cutoff using a varistor.

Note) 5. The 17-bit absolute encoder can also be used as a 17-bit incremental encoder.

Permissible Load at Output Shaft

The radial load is defined as a load applied to the output shaft in the right-angle direction. This load is generated when the gear head is coupled to the machine using a chain, belt, etc., but not when the gear head is directly connected to the coupling. As shown in the right figure, the permissible value is determined based on the load applied to the L/2 position of the output shaft. The thrust load is defined as a load applied to the output shaft in the axial direction.

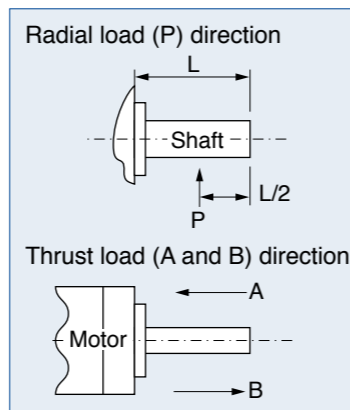

**Because the radial load and thrust load significantly affect the life of the bearing, take care not to allow the load during operation to exceed the permissible radial load and thrust load shown in the table below.**

Built-in Holding Brake

In the applications where the motor drives the vertical axis, this brake would be used to hold and prevent the work (moving load) from falling by gravity while the power to the servo is shut off.

**Use this built-in brake for "Holding" purpose only, that is to hold the stalling status. Never use this for "Brake" purpose to stop the load in motion.**

• Output Timing of BRK-OFF Signal

- For the brake release timing at power-on, or braking timing at Servo-OFF/Servo-Alarm while the motor is in motion, refer to the Operating Instructions (Overall).
- With the parameter, Pr4.38 (Setup of mechanical brake action while the motor is in motion), you can set up a time between when the motor enters to a free-run from energized status and when BRK-OFF signal turns off (brake will be engaged), when the Servo-OFF or alarm occurs while the motor is in motion. For details, download a copy of the instruction manual from our website.

<Note>

1. The lining sound of the brake (chattering and etc.) might be generated while running the motor with built-in brake, however this does not affect any functionality.
2. Magnetic flux might be generated through the motor shaft while the brake coil is energized (brake is open). Pay an extra attention when magnetic sensors are used nearby the motor.

• Specifications of Built-in Holding Brake

Motor series	Motor output	Static friction torque N·m	Rotor inertia $\times 10^{-4}$ kg·m <sup>2</sup>	Engaging time ms	Releasing time ms	Exciting current DC A (at cool-off)	Releasing voltage	Permissible work (J) per one braking	Permissible total work $\times 10^3$ J	Permissible angular acceleration rad/s <sup>2</sup>	
MSMD	50 W, 100 W	0.29 or more	0.002	35 or less	20 or less	0.3	DC1 V or more	39.2	4.9	30000	
	200 W, 400 W	1.27 or more	0.018	50 or less	15 or less	0.36		137	44.1		
	750 W	2.45 or more	0.075	70 or less	20 or less	0.42		196	147		
MSME	50 W, 100 W	0.29 or more	0.002	35 or less	20 or less	0.3	DC1 V or more	39.2	4.9	30000	
	200 W, 400 W	1.27 or more	0.018	50 or less	15 or less	0.36		137	44.1		
	750 W(200 V)	2.45 or more	0.075	70 or less	20 or less	0.42		196	147		
	750 W(400 V)	2.5 or more	0.33	50 or less	15 or less (100)	0.81	DC2 V or more	392	490	10000	
	1.0 kW, 1.5 kW, 2.0 kW	7.8 or more									
	3.0 kW	11.8 or more	80 or less								
4.0 kW, 5.0 kW	16.2 or more	1.35	110 or less	50 or less (130)	0.9	1470	2200				
MDME	400 W(400 V), 600 W(400 V)	2.5 or more	1.35	50 or less	15 or less	0.7	DC2 V or more	392	490	10000	
	1.0 kW	4.9 or more		80 or less	70 or less (200)	0.59		588	780		
	1.5 kW, 2.0 kW	13.7 or more		100 or less	50 or less (130)	0.79		1176	1500		
	3.0 kW	16.2 or more	110 or less	0.9	1470	2200					
	4.0 kW, 5.0 kW	24.5 or more	4.7	80 or less	25 or less (200)	1.3	1372	2900	5440		
	7.5 kW	58.8 or more		150 or less	50 or less	1.4			5000		
	11.0 kW, 15.0 kW	100 or more	7.1	300 or less	140 or less	1.08	2000	4000	3000		
MFME	1.5 kW	7.8 or more	4.7	80 or less	35 or less	0.83	DC2 V or more	1372	2900	10000	
	2.5 kW	21.6 or more	8.75	150 or less	100 or less	0.75		1470	1500		
	4.5 kW	31.4 or more						2200			
MGME	0.9 kW	13.7 or more	1.35	100 or less	50 or less (130)	0.79	DC2 V or more	1176	1500	10000	
	2.0 kW	24.5 or more	4.7	80 or less	25 or less (200)	1.3					
	3.0 kW	58.8 or more		150 or less	50 or less (130)	1.4		1372	2900	5440	
	4.5 kW, 6.0 kW		50 or less		5000						
MHMD MSMJ MHMJ	200 W, 400 W	1.27 or more	0.018	50 or less	15 or less	0.36	DC1 V or more	137	44.1	30000	
	750 W	2.45 or more	0.075	70 or less	20 or less	0.42		196	147		
MHME	1.0 kW	4.9 or more	1.35	80 or less	70 or less (200)	0.59	DC2 V or more	588	780	10000	
	1.5 kW	13.7 or more		100 or less	50 or less (130)	0.79					
	2.0 kW~5.0 kW	24.5 or more	4.7	80 or less	25 or less (200)	1.3		1372	2900		5440
	7.5 kW	58.8 or more		150 or less	50 or less	1.4					5000

- Excitation voltage is DC24 V $\pm$ 10 % (Large type motor) and DC24 V $\pm$ 5 % (Small type motor).
- Releasing time values represent the ones with DC-cutoff using a varistor.  
Values in ( ) represent those measured by using a diode (V03C by Hitachi, Ltd.)
- Above values (except static friction torque, releasing voltage and excitation current) represent typical values.
- Backlash of the built-in holding brake is kept  $\pm 1^\circ$  or smaller at ex-factory point.
- Service life of the number of acceleration/deceleration with the above permissible angular acceleration is more than 10 million times. (Life end is defined as when the brake backlash drastically changes.)

Encoder Cable

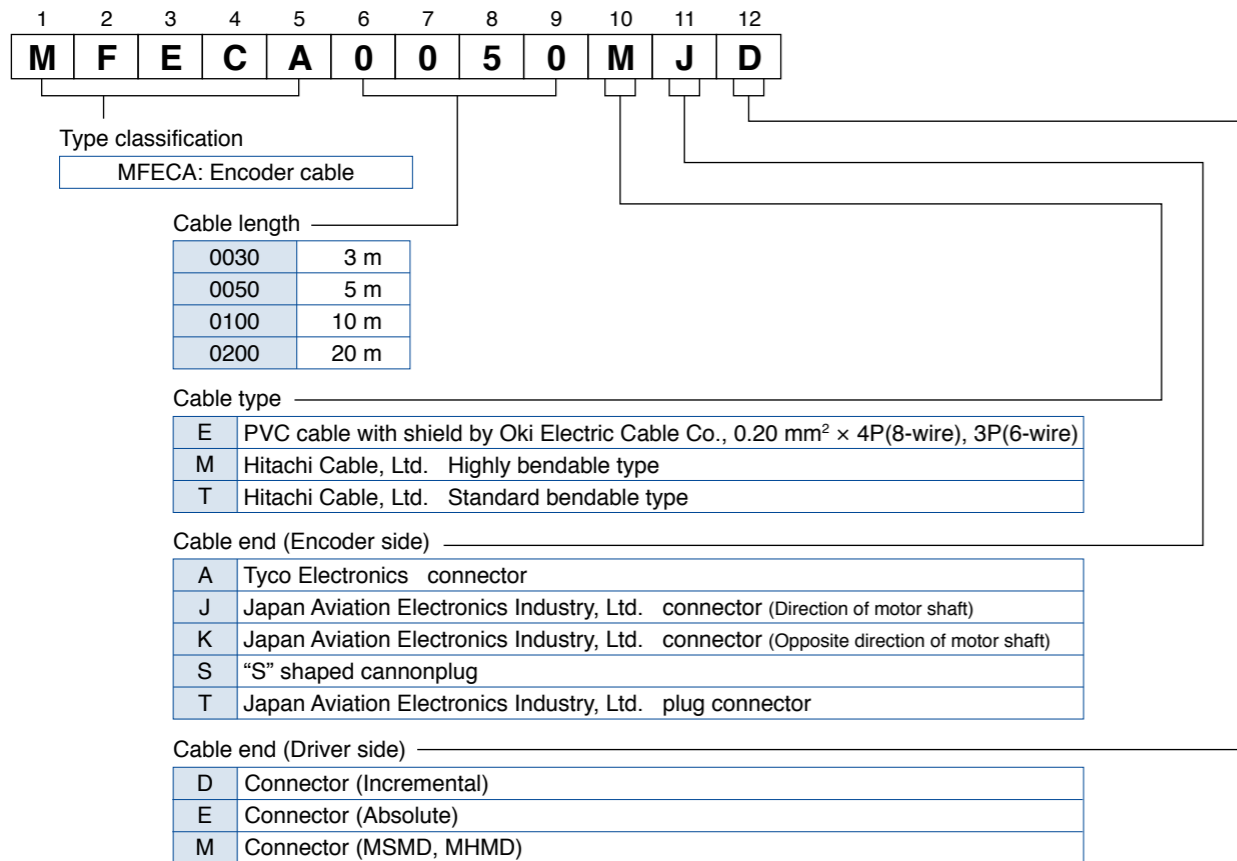

Motor Cable, Brake Cable

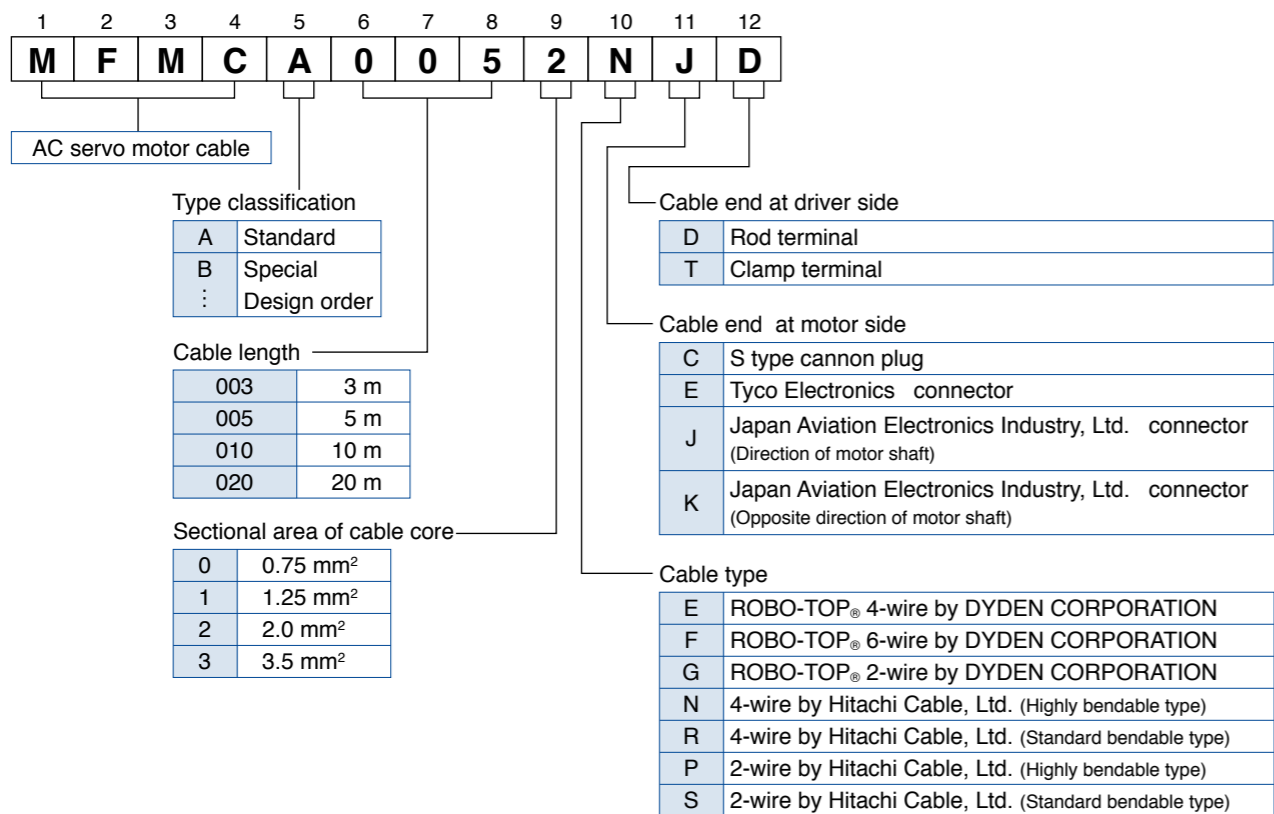

ROBO-TOP® is a trade mark of DYDEN CORPORATION

Specifications of Motor connector

• When the motors of <MSMD, MHMD, MSMJ, MHMJ> are used, they are connected as shown below.

Connector: Made by Tyco Electronics (The figures below show connectors for the motor.)

Connector for encoder

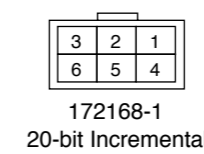
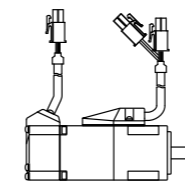

PIN No.	Application
1	NC
2	PS
3	PS
4	E5V
5	E0V
6	FG(SHIELD)

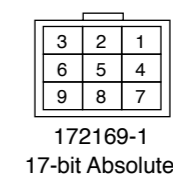

PIN No.	Application
1	BAT+
2	BAT-
3	FG(SHIELD)
4	PS
5	PS
6	NC
7	E5V
8	E0V
9	NC

<Remarks> Do not connect anything to NC.

Connector for brake

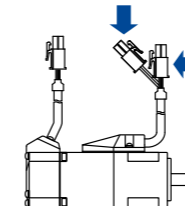

<Connector for motor>

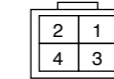

PIN No.	Application
1	U-phase
2	V-phase
3	W-phase
4	Ground

<Connector for brake>



PIN No.	Application
1	Brake
2	Brake

\* Electromagnetic brake is a nonpolar device.

• When the motors of <MSME (50 W to 750 W (200 V))> are used, they are connected as shown below.

Connector: Made by Japan Aviation Electronics Industry, Ltd. (The figures below show connectors for the motor.)

\* Do not remove the gasket supplied with the junction cable connector. Securely install the gasket in place. Otherwise, the degree of protection of IP67 will not be guaranteed.

Connector for encoder

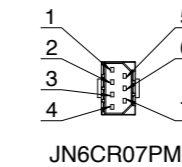

20-bit Incremental		17-bit Absolute	
PIN No.	Application	PIN No.	Application
1	FG(SHIELD)	1	FG(SHIELD)
2	—	2	BAT-
3	E0V	3	E0V
4	PS	4	PS
5	—	5	BAT+
6	E5V	6	E5V
7	PS	7	PS

Tightening torque of the screw (M2) 0.19 N·m to 0.21 N·m  
\* Be sure to use only the screw supplied with the connector, to avoid damage.

Connector for motor

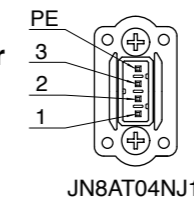

PIN No.	Application
1	U-phase
2	V-phase
3	W-phase
PE	Ground

Tightening torque of the screw (M2) 0.085 N·m to 0.095 N·m (screwed to plastic)  
\* Be sure to use only the screw supplied with the connector, to avoid damage.

[Motor with brake]

Connector for brake

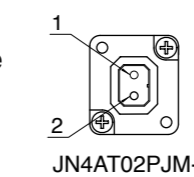

PIN No.	Application
1	Brake
2	Brake

\* Electromagnetic brake is a nonpolar device.  
Tightening torque of the screw (M2) 0.19 N·m to 0.21 N·m  
\* Be sure to use only the screw supplied with the connector, to avoid damage.

- When the motors of <MSME (750 W(400 V), 1.0 kW to 5.0 kW), MDME, MGME, MHME> are used, they are connected as shown below.

Connector: Made by Japan Aviation Electronics Industry, Ltd. (The figures below show connectors for the motor.)

Connector for encoder

<Encoder connector for IP65 motor>

<Encoder connector for IP67 motor>

IP65 motor Connector for encoder (Large type)

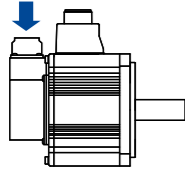

IP67 motor Connector for encoder (Small type)

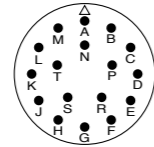
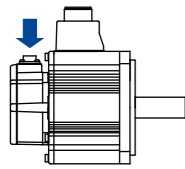

N/MS3102A20-29P

20-bit Incremental		17-bit Absolute	
PIN No.	Application	PIN No.	Application
A	NC	A	NC
B	NC	B	NC
C	NC	C	NC
D	NC	D	NC
E	NC	E	NC
F	NC	F	NC
G	E0V	G	E0V
H	E5V	H	E5V
J	FG(SHIELD)	J	FG(SHIELD)
K	PS	K	PS
L	PS	L	PS
M	NC	M	NC
N	NC	N	NC
P	NC	P	NC
R	NC	R	NC
S	NC	S	BAT-
T	NC	T	BAT+

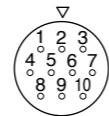

JN2AS10ML3-R

20-bit Incremental		17-bit Absolute	
PIN No.	Application	PIN No.	Application
1	E0V	1	E0V
2	NC	2	NC
3	PS	3	PS
4	E5V	4	E5V
5	NC	5	BAT-
6	NC	6	BAT+
7	PS	7	PS
8	NC	8	NC
9	FG(SHIELD)	9	FG(SHIELD)
10	NC	10	NC

<Remarks>

Do not connect anything to NC.

Connector for motor/brake

[0.9 kW to 5.0 kW]

Connector for motor/brake

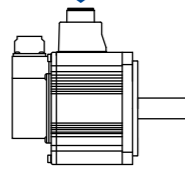

<without Brake>

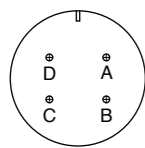

JL04V-2E20-4PE-B-R

MSME	750 W(400 V), 1.0 kW to 2.0 kW
MDME	400 W (400 V), 600 W (400 V), 1.0 kW to 2.0 kW
MGME	0.9 kW
MHME	1.0 kW to 1.5 kW

JL04HV-2E22-22PE-B-R

MSME	3.0 kW to 5.0 kW
MDME	3.0 kW to 5.0 kW
MGME	2.0 kW to 4.5 kW
MHME	2.0 kW to 5.0 kW

PIN No.	Application
A	U-phase
B	V-phase
C	W-phase
D	Ground

<with Brake>

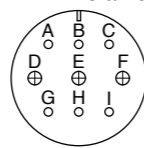

JL04V-2E24-11PE-B-R

[200 V]

MSME	3.0 kW to 5.0 kW
MDME	3.0 kW to 5.0 kW
MFME*	2.5 kW, 4.5 kW
MGME	2.0 kW to 4.5 kW
MHME	2.0 kW to 5.0 kW

PIN No.	Application
A	U-phase
B	V-phase
C	W-phase
D	Ground
E	Ground
F	W-phase
G	Ground
H	Ground
I	NC

\* Electromagnetic brake is a nonpolar device.

[6.0 kW or more]

Connector for motor  
Connector for brake

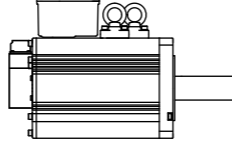

<Motor>

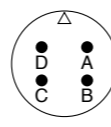

JL04V-2E32-17PE-B-R

MDME	7.5 kW to 15.0 kW
MGME	6.0 kW
MHME	7.5 kW

PIN No.	Application
A	U-phase
B	V-phase
C	W-phase
D	Ground

<Brake>

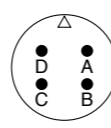

N/MS3102A 14S-2P

MDME	7.5 kW to 15.0 kW
MGME	6.0 kW
MHME	7.5 kW

PIN No.	Application
A	Brake
B	Brake
C	NC
D	NC

\* Electromagnetic brake is a nonpolar device.

\* MFME is common to with or without brake.

<Remarks>

Do not connect anything to NC.

Encoder Cable

\* It doesn't correspond to IP65 and IP67.

Part No.	MFECA0 ** 0EAM	Compatible motor output	MSMD 50 W to 750 W, MSMJ 200 W to 750 W	MHMD 200 W to 750 W, MHMJ 200 W to 750 W
Specifications	For 20-bit incremental encoder (Without battery box)			

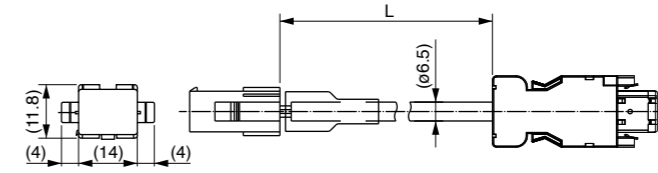

[Unit: mm]

Title	Part No.	Manufacturer	L (m)	Part No.
Connector (Driver side)	3E206-0100 KV	Sumitomo 3M (or equivalent)	3	MFECA0030EAM
Shell kit	3E306-3200-008		5	MFECA0050EAM
Connector (Motor side)	172160-1	Tyco Electronics	10	MFECA0100EAM
Connector pin	170365-1		20	MFECA0200EAM
Cable	0.20 mm <sup>2</sup> ×3P (6-wire)		Ok Electric Cable Co., Ltd.	

Part No.	MFECA0 ** 0EAE	Compatible motor output	MSMD 50 W to 750 W, MSMJ 200 W to 750 W	MHMD 200 W to 750 W, MHMJ 200 W to 750 W
Specifications	For 17-bit absolute encoder (With battery box)			

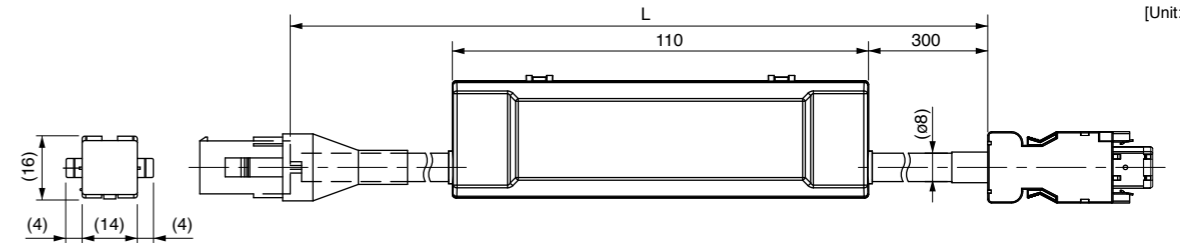

[Unit: mm]

Title	Part No.	Manufacturer	L (m)	Part No.
Connector (Driver side)	3E206-0100 KV	Sumitomo 3M (or equivalent)	3	MFECA0030EAE
Shell kit	3E306-3200-008		5	MFECA0050EAE
Connector (Motor side)	172161-1	Tyco Electronics	10	MFECA0100EAE
Connector pin	170365-1		20	MFECA0200EAE
Cable	0.20 mm <sup>2</sup> ×4P (8-wire)		Ok Electric Cable Co., Ltd.	

Part No.	MFECA0 ** 0EAD	Compatible motor output	MSMD 50 W to 750 W, MSMJ 200 W to 750 W	MHMD 200 W to 750 W, MHMJ 200 W to 750 W
Specifications	For 17-bit incremental encoder (Without battery box)			

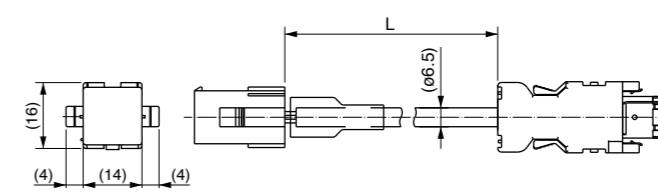

[Unit: mm]

Title	Part No.	Manufacturer	L (m)	Part No.
Connector (Driver side)	3E206-0100 KV	Sumitomo 3M (or equivalent)	3	MFECA0030EAD
Shell kit	3E306-3200-008		5	MFECA0050EAD
Connector (Motor side)	172161-1	Tyco Electronics	10	MFECA0100EAD
Connector pin	170365-1		20	MFECA0200EAD
Cable	0.20 mm <sup>2</sup> ×3P (6-wire)		Ok Electric Cable Co., Ltd.	

Encoder Cable

\* It doesn't correspond to IP65 and IP67.

Part No.	MFECA0 ** 0MJD (Highly bendable type, Direction of motor shaft)	Compatible motor output	MSME 50 W to 750 W (200 V)
	MFECA0 ** 0MKD (Highly bendable type, Opposite direction of motor shaft)		
	MFECA0 ** 0TJD (Standard bendable type, Direction of motor shaft)		
	MFECA0 ** 0TKD (Standard bendable type, Opposite direction of motor shaft)		
Specifications	For 20-bit incremental encoder (Without battery box) * 17bit-use is possible		

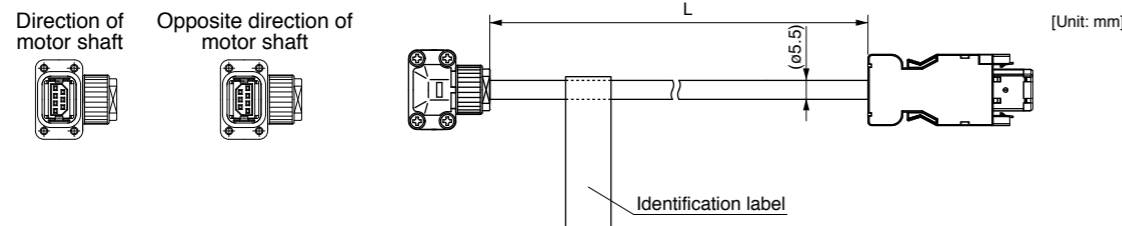

Title	Part No.	Manufacturer	L (m)	Part No.(ex.)
Connector (Driver side)	3E206-0100 KV	Sumitomo 3M (or equivalent)	3	MFECA0030MJD
Shell kit	3E306-3200-008			
Connector (Motor side)	JN6FR07SM1	Japan Aviation Electronics Ind.	10	MFECA0100MJD
Connector pin	LY10-C1-A1-10000			
Cable	AWG24 4-wire, AWG22 2-wire (ø5.5)	Hitachi Cable, Ltd.	20	MFECA0200MJD

Part No.	MFECA0 ** 0MJE (Highly bendable type, Direction of motor shaft)	Compatible motor output	MSME 50 W to 750 W (200 V)
	MFECA0 ** 0MKE (Highly bendable type, Opposite direction of motor shaft)		
	MFECA0 ** 0TJE (Standard bendable type, Direction of motor shaft)		
	MFECA0 ** 0TKE (Standard bendable type, Opposite direction of motor shaft)		
Specifications	For 17-bit absolute encoder (With battery box)		

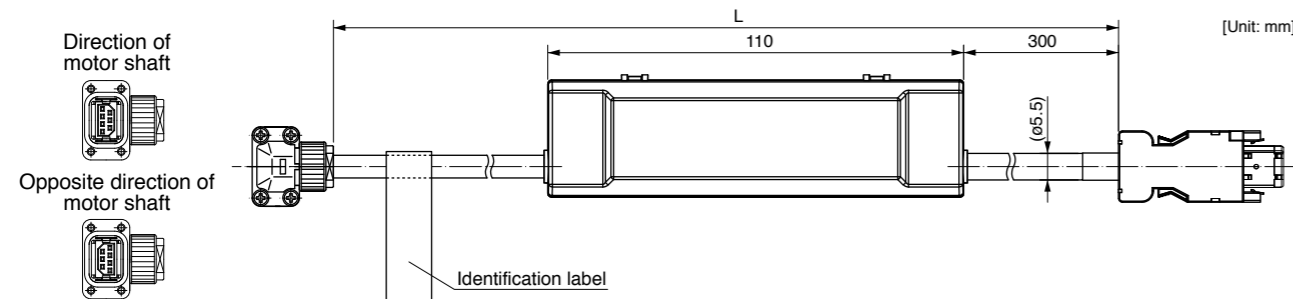

Title	Part No.	Manufacturer	L (m)	Part No.(ex.)
Connector (Driver side)	3E206-0100 KV	Sumitomo 3M (or equivalent)	3	MFECA0030MJE
Shell kit	3E306-3200-008			
Connector (Motor side)	JN6FR07SM1	Japan Aviation Electronics Ind.	10	MFECA0100MJE
Connector pin	LY10-C1-A1-10000			
Cable	AWG24 4-wire, AWG22 2-wire (ø5.5)	Hitachi Cable, Ltd.	20	MFECA0200MJE

Part No.	MFECA0 ** 0ESD	Compatible motor output	MDME 400 W(400 V), MDME 600 W(400 V) MSME 750 W(400 V) 0.9 kW to 15.0 kW (IP65 Motor)
Specifications	For 20-bit incremental encoder (Without battery box)		

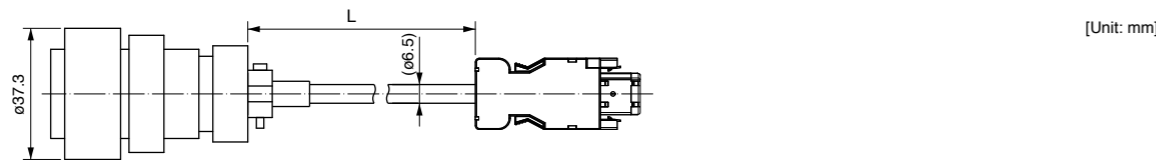

Title	Part No.	Manufacturer	L (m)	Part No.
Connector (Driver side)	3E206-0100 KV	Sumitomo 3M (or equivalent)	3	MFECA0030ESD
Shell kit	3E306-3200-008			
Connector (Motor side)	N/MS3106B20-29S	Japan Aviation Electronics Ind.	10	MFECA0100ESD
Cable clamp	N/MS3057-12A			
Cable	0.2 mm <sup>2</sup> x3P (6-wire)	Ok Electric Cable Co., Ltd.	20	MFECA0200ESD

Part No.	MFECA0 ** 0ETD	Compatible motor output	MDME 400 W(400 V), MDME 600 W(400 V), MSME 750 W(400 V) 0.9 kW to 15.0 kW (IP67 Motor)
Specifications	For 20-bit incremental encoder (Without battery box)		

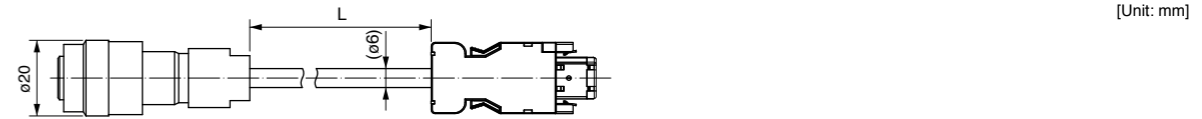

Title	Part No.	Manufacturer	L (m)	Part No.
Connector (Driver side)	3E206-0100 KV	Sumitomo 3M (or equivalent)	3	MFECA0030ETD
Shell kit	3E306-3200-008			
Connector (Motor side)	JN2DS10SL1-R	Japan Aviation Electronics Ind.	10	MFECA0100ETD
Connector pin	JN1-22-22S-PKG100			
Cable	0.2 mm <sup>2</sup> x3P (6-wire)	Ok Electric Cable Co., Ltd.	20	MFECA0200ETD

Part No.	MFECA0 ** 0ESE	Compatible motor output	0.9 kW to 5.0 kW (IP65 Motor)
Specifications	For 17-bit absolute encoder (With battery box)		

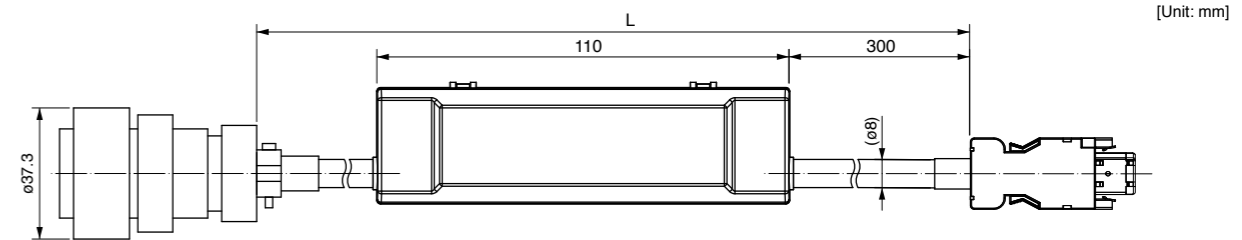

Title	Part No.	Manufacturer	L (m)	Part No.
Connector (Driver side)	3E206-0100 KV	Sumitomo 3M (or equivalent)	3	MFECA0030ESE
Shell kit	3E306-3200-008			
Connector (Motor side)	N/MS3106B20-29S	Japan Aviation Electronics Ind.	10	MFECA0100ESE
Cable clamp	N/MS3057-12A			
Cable	0.2 mm <sup>2</sup> x4P (8-wire)	Ok Electric Cable Co., Ltd.	20	MFECA0200ESE

Part No.	MFECA0 ** 0ETE	Compatible motor output	MDME 400 W(400 V), MDME 600 W(400 V) MSME 750 W(400 V) 0.9 kW to 15.0 kW (IP67 Motor)
Specifications	For 17-bit absolute encoder (With battery box)		

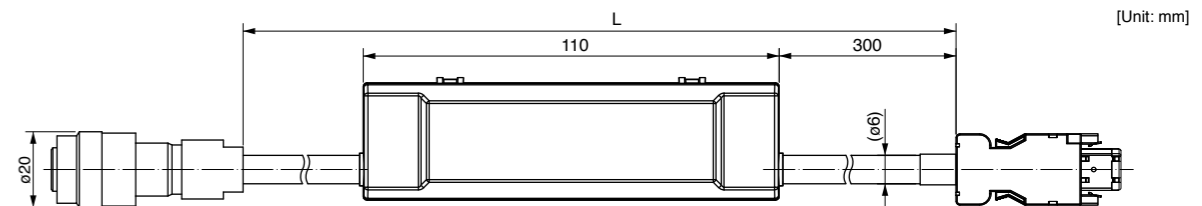

Title	Part No.	Manufacturer	L (m)	Part No.
Connector (Driver side)	3E206-0100 KV	Sumitomo 3M (or equivalent)	3	MFECA0030ETE
Shell kit	3E306-3200-008			
Connector (Motor side)	JN2DS10SL1-R	Japan Aviation Electronics Ind.	10	MFECA0100ETE
Connector pin	JN1-22-22S-PKG100			
Cable	0.2 mm <sup>2</sup> x3P (6-wire)	Ok Electric Cable Co., Ltd.	20	MFECA0200ETE



Motor Cable (without Brake)

\* It doesn't correspond to IP65 and IP67.

<b>Part No.</b>	<b>MFMCA0 ** 0EED</b>	<b>Applicable model</b>	MSMD 50 W to 750 W, MHMD 200 W to 750 W MSMJ 200 W to 750 W, MHMJ 200 W to 750 W
-----------------	-----------------------	-------------------------	---

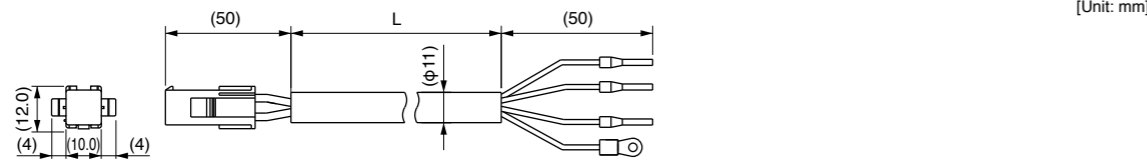

[Unit: mm]

Title	Part No.	Manufacturer	L (m)	Part No.
Connector	172159-1	Tyco Electronics	3	MFMCA0030EED
Connector pin	170366-1		5	MFMCA0050EED
Rod terminal	A10.75-8GY	Phoenix Contact	10	MFMCA0100EED
Nylon insulated round terminal	N1.25-M4	J.S.T Mfg. Co., Ltd.	20	MFMCA0200EED
Cable	ROBO-TOP 600V 0.75mm <sup>2</sup> 4-wire	DYDEN CORPORATION		

<b>Part No.</b>	<b>MFMCA0 ** 0NJD</b> (Highly bendable type, Direction of motor shaft)	<b>Applicable model</b>	MSME 50 W to 750 W(200V)
	<b>MFMCA0 ** 0NKD</b> (Highly bendable type, Opposite direction of motor shaft)		MSME 200 W to 750 W(200V)
	<b>MFMCA0 ** 0RJD</b> (Standard bendable type, Direction of motor shaft)		MSME 50 W to 750 W(200V)
	<b>MFMCA0 ** 0RKD</b> (Standard bendable type, Opposite direction of motor shaft)		MSME 200 W to 750 W(200V)

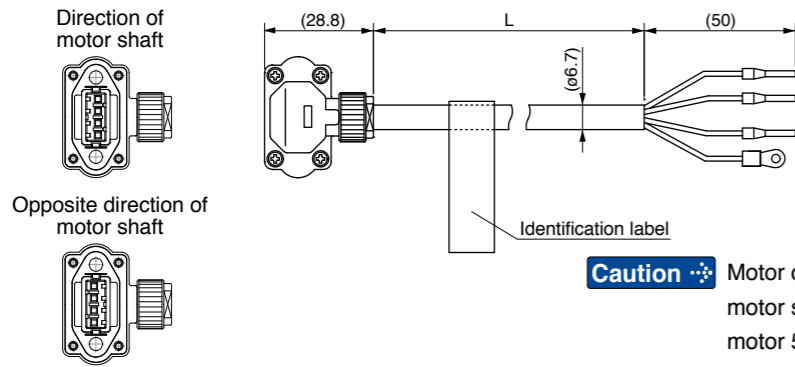

[Unit: mm]

Title	Part No.	Manufacturer	L (m)	Part No.(ex.)
Connector	JN8FT04SJ1	Japan Aviation Electronics Ind.	3	MFMCA0030NJD
Connector pin	ST-TMH-S-C1B-3500		5	MFMCA0050NJD
Rod terminal	A10.75-8GY	Phoenix Contact	10	MFMCA0100NJD
Nylon insulated round terminal	N1.25-M4	J.S.T Mfg. Co., Ltd.	20	MFMCA0200NJD
Cable	AWG18 4-wire (φ6.7)	Hitachi Cable, Ltd.		

<b>Part No.</b>	<b>MFMCA0 ** 2ECD</b>	<b>Applicable model</b>	MFME 1.5 kW(200 V)
-----------------	-----------------------	-------------------------	--------------------

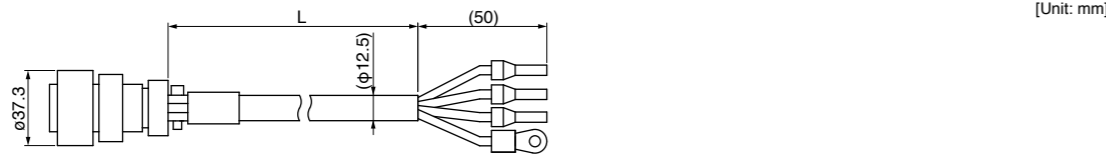

[Unit: mm]

Title	Part No.	Manufacturer	L (m)	Part No.
Connector	JL04V-6A20-18SE-EB-R	Japan Aviation Electronics Ind.	3	MFMCA0032ECD
Cable clamp	JL04-2022CK(14)-R		5	MFMCA0052ECD
Rod terminal	NTUB-2	J.S.T Mfg. Co., Ltd.	10	MFMCA0102ECD
Nylon insulated round terminal	N2-M4		20	MFMCA0202ECD
Cable	ROBO-TOP 600V 2.0mm <sup>2</sup> 4-wire	DYDEN CORPORATION		

<b>Part No.</b>	<b>MFMCD0 ** 2ECD</b>	<b>Applicable model</b>	MSME 750 W(400 V), 1.0 kW to 2.0 kW, MDME 400 W(400 V), 600 W(400 V), 1.0 kW to 2.0 kW MHME 1.0 kW to 1.5 kW, MGME 0.9 kW (All model 200 V and 400 V commonness)
-----------------	-----------------------	-------------------------	---

[Unit: mm]

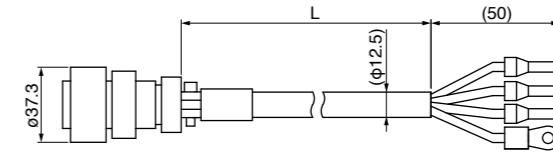

Title	Part No.	Manufacturer	L (m)	Part No.
Connector	JL04V-6A20-4SE-EB-R	Japan Aviation Electronics Ind.	3	MFMCD0032ECD
Cable clamp	JL04-2022CK(14)-R		5	MFMCD0052ECD
Rod terminal	NTUB-2	J.S.T Mfg. Co., Ltd.	10	MFMCD0102ECD
Nylon insulated round terminal	N2-M4		20	MFMCD0202ECD
Cable	ROBO-TOP 600 V 2.0 mm <sup>2</sup> 4-wire	DYDEN CORPORATION		

<b>Part No.</b>	<b>MFMCE0 ** 2ECD</b>	<b>Applicable model</b>	MHME 2.0 kW (200 V and 400 V commonness)
-----------------	-----------------------	-------------------------	---

[Unit: mm]

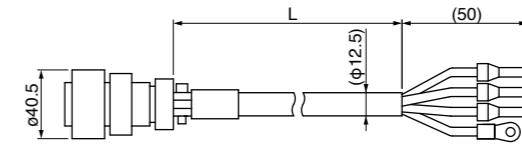

Title	Part No.	Manufacturer	L (m)	Part No.
Connector	JL04V-6A22-22SE-EB-R	Japan Aviation Electronics Ind.	3	MFMCE0032ECD
Cable clamp	JL04-2022CK(14)-R		5	MFMCE0052ECD
Rod terminal	NTUB-2	J.S.T Mfg. Co., Ltd.	10	MFMCE0102ECD
Nylon insulated round terminal	N2-M4		20	MFMCE0202ECD
Cable	ROBO-TOP 600 V 2.0 mm <sup>2</sup> 4-wire	DYDEN CORPORATION		

<b>Part No.</b>	<b>MFMCF0 ** 2ECD</b>	<b>Applicable model</b>	MFME 1.5 kW(400 V), 2.5 kW(200 V and 400 V commonness)
-----------------	-----------------------	-------------------------	--

[Unit: mm]

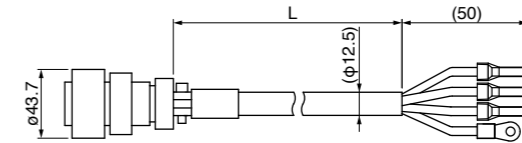

Title	Part No.	Manufacturer	L (m)	Part No.
Connector	JL04V-6A24-11SE-EB-R	Japan Aviation Electronics Ind.	3	MFMCF0032ECD
Cable clamp	JL04-2428CK(17)-R		5	MFMCF0052ECD
Rod terminal	NTUB-2	J.S.T Mfg. Co., Ltd.	10	MFMCF0102ECD
Nylon insulated round terminal	N2-M4		20	MFMCF0202ECD
Cable	ROBO-TOP 600 V 2.0 mm <sup>2</sup> 4-wire	DYDEN CORPORATION		

Motor Cable (without Brake)

\* It doesn't correspond to IP65 and IP67.

<b>Part No.</b>	<b>MFMCA0 ** 3ECT</b>	<b>Applicable model</b>	MSME 3.0 kW to 5.0 kW, MDME 3.0kW to 5.0 kW MHME 3.0 kW to 5.0 kW, MGME 2.0kW to 4.5 kW (All model 200 V and 400 V commonness)
-----------------	-----------------------	-------------------------	--

[Unit: mm]

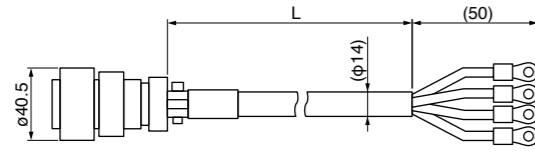

Title	Part No.	Manufacturer	L (m)	Part No.
Connector	JL04V-6A22-22SE-EB-R	Japan Aviation Electronics Ind.	3	MFMCA0033ECT
Cable clamp	JL04-2022CK(14)-R		5	MFMCA0053ECT
Nylon insulated round terminal	N5.5-5	J.S.T Mfg. Co., Ltd.	10	MFMCA0103ECT
Cable	ROBO-TOP 600 V 3.5 mm <sup>2</sup> 4-wire	DYDEN CORPORATION	20	MFMCA0203ECT

<b>Part No.</b>	<b>MFMCD0 ** 3ECT</b>	<b>Applicable model</b>	MFME 4.5 kW (200 V and 400 V commonness)
-----------------	-----------------------	-------------------------	---

[Unit: mm]

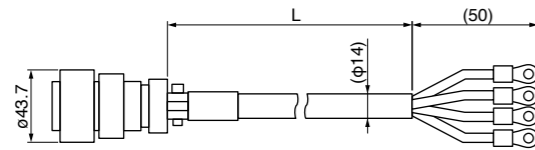

Title	Part No.	Manufacturer	L (m)	Part No.
Connector	JL04V-6A24-11SE-EB-R	Japan Aviation Electronics Ind.	3	MFMCD0033ECT
Cable clamp	JL04-2428CK(17)-R		5	MFMCD0053ECT
Nylon insulated round terminal	N5.5-5	J.S.T Mfg. Co., Ltd.	10	MFMCD0103ECT
Cable	ROBO-TOP 600 V 3.5 mm <sup>2</sup> 4-wire	DYDEN CORPORATION	20	MFMCD0203ECT

Motor Cable (with Brake)

\* It doesn't correspond to IP65 and IP67.

<b>Part No.</b>	<b>MFMCA0 ** 2FCD</b>	<b>Applicable model</b>	MSME 1.0 kW to 2.0 kW(200 V), MDME 1.0 kW to 2.0 kW(200 V), MFME 1.5 kW(200 V), MHME 1.0 kW(200 V) to 1.5 kW(200 V) MGME 0.9 kW(200V )
-----------------	-----------------------	-------------------------	--

[Unit: mm]

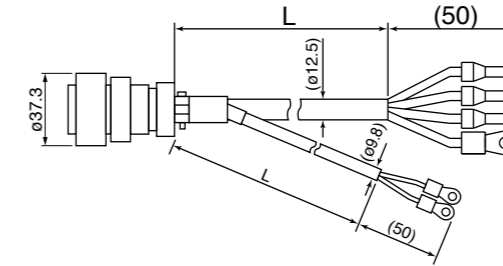

Title	Part No.	Manufacturer	L (m)	Part No.	
Connector	JL04V-6A20-18SE-EB-R	Japan Aviation Electronics Ind.	3	MFMCA0032FCD	
Cable clamp	JL04-2022CK(14)-R		5	MFMCA0052FCD	
Rod terminal	NTUB-2	J.S.T Mfg. Co., Ltd.	10	MFMCA0102FCD	
Nylon insulated round terminal	Earth	N2-M4	J.S.T Mfg. Co., Ltd.	20	MFMCA0202FCD
	Brake	N1.25-M4			
Cable	ROBO-TOP 600 V 0.75 mm <sup>2</sup> and ROBO-TOP 600 V 2.0 mm <sup>2</sup> 6-wire	DYDEN CORPORATION			

<b>Part No.</b>	<b>MFMCE0 ** 2FCD</b>	<b>Applicable model</b>	MSME 750 W(400 V) to 2.0 kW(400 V), MDME 400 W(400 V) to 2.0 kW(400 V), MFME 1.5 kW(400 V), 2.5 kW(200 V/400 V), MGME 0.9 kW(400 V) MHME 1.0 kW(400 V), 1.5 kW(400 V), 2.0 kW(200 V/400 V)
-----------------	-----------------------	-------------------------	--

[Unit: mm]

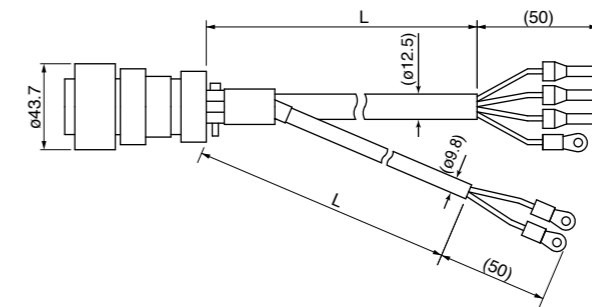

Title	Part No.	Manufacturer	L (m)	Part No.	
Connector	JL04V-6A24-11SE-EB-R	Japan Aviation Electronics Ind.	3	MFMCE0032FCD	
Cable clamp	JL04-2428CK(17)-R		5	MFMCE0052FCD	
Rod terminal	NTUB-2	J.S.T Mfg. Co., Ltd.	10	MFMCE0102FCD	
Nylon insulated round terminal	Earth	N2-M4	J.S.T Mfg. Co., Ltd.	20	MFMCE0202FCD
	Brake	N1.25-M4			
Cable	ROBO-TOP 600 V 0.75 mm <sup>2</sup> and ROBO-TOP 600 V 2.0 mm <sup>2</sup> 6-wire	DYDEN CORPORATION			

Motor Cable (with Brake)

\* It doesn't correspond to IP65 and IP67.

Part No.	<b>MFMCA0 ** 3FCT</b>	Applicable model	MSME 3.0 kW to 5.0 kW, MDME 3.0 kW to 5.0 kW MFME 4.5 kW, MHME 3.0 kW to 5.0 kW MGME 2.0 kW to 4.5 kW (All model 200 V and 400 V commonness)
----------	-----------------------	------------------	---

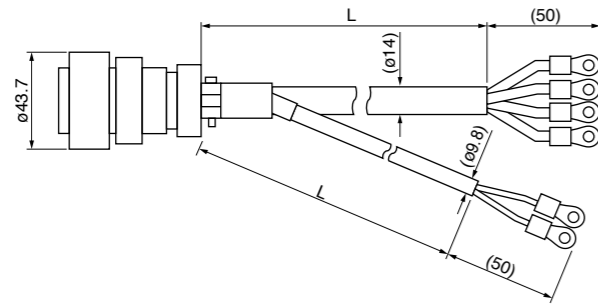

[Unit: mm]

Title	Part No.	Manufacturer
Connector	JL04V-6A24-11SE-EB-R	Japan Aviation Electronics Ind.
Cable clamp	JL04-2428CK(17)-R	Japan Aviation Electronics Ind.
Nylon insulated round terminal	Earth N5.5-5	J.S.T Mfg. Co., Ltd.
	Brake N1.25-M4	
Cable	ROBO-TOP 600 V 0.75 mm <sup>2</sup> and ROBO-TOP 600 V 3.5 mm <sup>2</sup> 6-wire	DYDEN CORPORATION

L (m)	Part No.
3	MFMCA0033FCT
5	MFMCA0053FCT
10	MFMCA0103FCT
20	MFMCA0203FCT

Brake Cable

\* It doesn't correspond to IP65 and IP67.

Part No.	<b>MFMCB0 ** 0GET</b>	Applicable model	MSMD 50 W to 750 W, MHMD 200 W to 750 W MSMJ 200 W to 750 W, MHMJ 200 W to 750 W
----------	-----------------------	------------------	---

[Unit: mm]

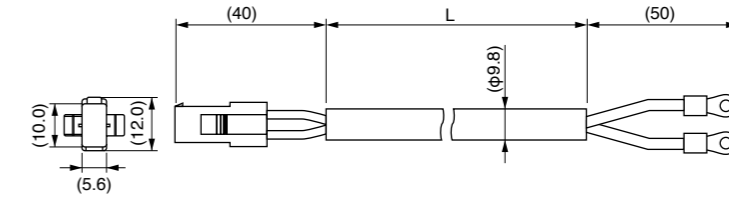

Title	Part No.	Manufacturer	L (m)	Part No.
Connector	172157-1	Tyco Electronics	3	MFMCB0030GET
Connector pin	170366-1, 170362-1		5	MFMCB0050GET
Nylon insulated round terminal	N1.25-M4	J.S.T Mfg. Co., Ltd.	10	MFMCB0100GET
Cable	ROBO-TOP 600 V 0.75 mm <sup>2</sup> 2-wire	DYDEN CORPORATION	20	MFMCB0200GET

Part No.	<b>MFMCB0 ** 0PJT</b> (Highly bendable type, Direction of motor shaft)	Applicable model	MSME 50 W to 750 W (200 V)
	<b>MFMCB0 ** 0PKT</b> (Highly bendable type, Opposite direction of motor shaft)		
	<b>MFMCB0 ** 0SJT</b> (Standard bendable type, Direction of motor shaft)		
	<b>MFMCB0 ** 0SKT</b> (Standard bendable type, Opposite direction of motor shaft)		

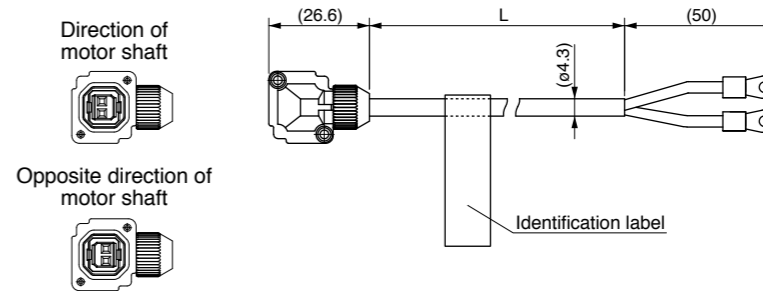

[Unit: mm]

Title	Part No.	Manufacturer	L (m)	Part No.
Connector	JN4FT02SJMR	Japan Aviation Electronics Ind.	3	MFMCB0030PJT
Connector pin	ST-TMH-S-C1B-3500		5	MFMCB0050PJT
Nylon insulated round terminal	N1.25-M4	J.S.T Mfg. Co., Ltd.	10	MFMCB0100PJT
Cable	AWG22 2-wire (ø4.3)	Hitachi Cable, Ltd.	20	MFMCB0200PJT

Cable for Interface

Part No.	DV0P4360
----------	----------

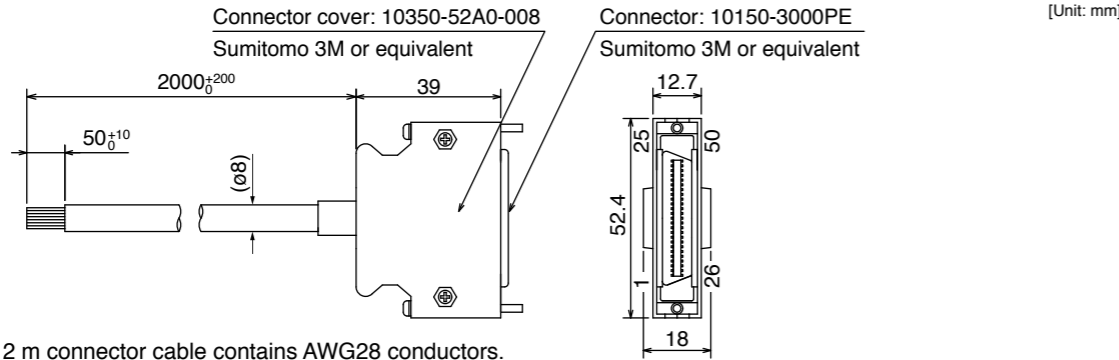

This 2 m connector cable contains AWG28 conductors.

• Table for wiring

Pin No.	color	Pin No.	color	Pin No.	color	Pin No.	color	Pin No.	color
1	Orange (Red1)	11	Orange (Black2)	21	Orange (Red3)	31	Orange (Red4)	41	Orange (Red5)
2	Orange (Black1)	12	Yellow (Black1)	22	Orange (Black3)	32	Orange (Black4)	42	Orange (Black5)
3	Gray (Red1)	13	Gray (Red2)	23	Gray (Red3)	33	Gray (Red4)	43	Gray (Red5)
4	Gray (Black1)	14	Gray (Black2)	24	Gray (Black3)	34	White (Red4)	44	White (Red5)
5	White (Red1)	15	White (Red2)	25	White (Red3)	35	White (Black4)	45	White (Black5)
6	White (Black1)	16	Yellow (Red2)	26	White (Black3)	36	Yellow (Red4)	46	Yellow (Red5)
7	Yellow (Red1)	17	Yel (Blk2)/Pink (Blk2)	27	Yellow (Red3)	37	Yellow (Black4)	47	Yellow (Black5)
8	Pink (Red1)	18	Pink (Red2)	28	Yellow (Black3)	38	Pink (Red4)	48	Pink (Red5)
9	Pink (Black1)	19	White (Black2)	29	Pink (Red3)	39	Pink (Black4)	49	Pink (Black5)
10	Orange (Red2)	20	-	30	Pink (Black3)	40	Gray (Black4)	50	Gray (Black5)

<Remarks>

Color designation of the cable e.g.) Pin-1 Cable color : Orange (Red1) : One red dot on the cable  
The shield of this cable is connected to the connector shell but not to the terminal.

Interface Conversion Cable

Part No.	DV0P4120, 4121, 4130, 4131, 4132
----------	----------------------------------

Interface cables for old product (XX series or V series) can be connected to the current product by using the connector conversion cable shown below.

DV0P4120	MINAS XX → A5II, A5 series (A4, A series) for position control/ velocity control
DV0P4121	MINAS XX → A5II, A5 series (A4, A series) for torque control
DV0P4130	MINAS V → A5II, A5 series (A4, A series) for position control
DV0P4131	MINAS V → A5II, A5 series (A4, A series) for velocity control
DV0P4132	MINAS V → A5II, A5 series (A4, A series) for torque control

\* For details of wiring, contact our sales department.

Converts 36-pin configuration to 50-pin.

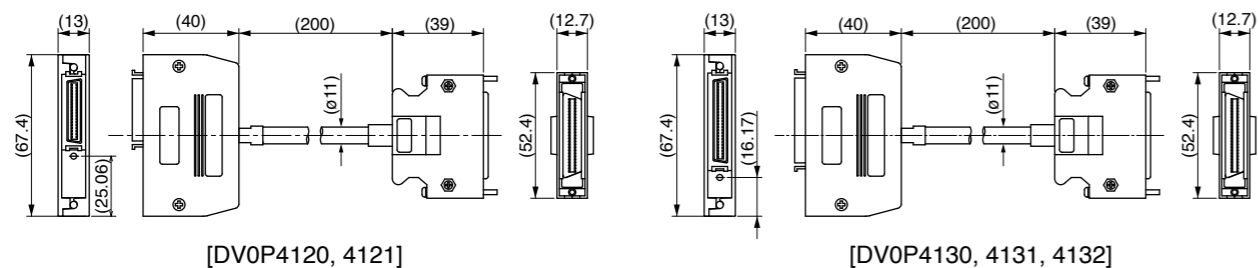

Connector Kit

Connector Kit for Communication Cable (for RS485, RS232) (Excluding A5IE, A5E Series)

Part No.	DV0PM20024
----------	------------

• Components

Title	Part No.	Manufacturer	Note
Connector	2040008-1	Tyco Electronics	For Connector X2 (8-pins)

• Pin disposition of connector, connector X2

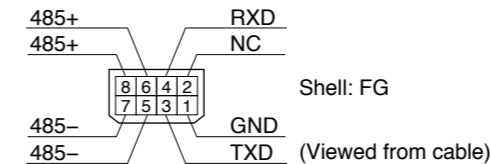

• Dimensions

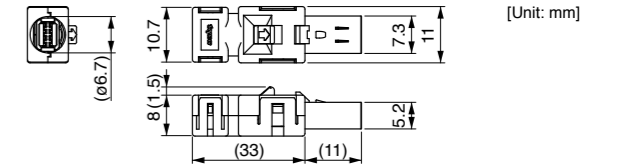

Connector Kit for Safety (Excluding A5IE, A5E Series)

Part No.	DV0PM20025
----------	------------

• Components

Title	Part No.	Manufacturer	Note
Connector	2013595-1	Tyco Electronics	For Connector X3 (8-pins)

• Pin disposition of connector, connector X3

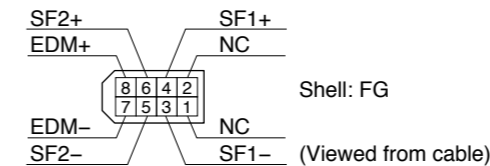

• Dimensions

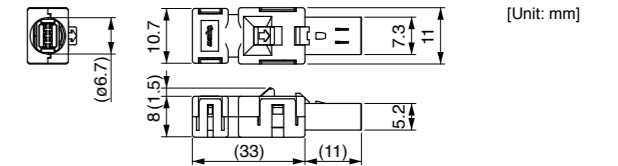

Connector Kit for Interface

Part No.	DV0P4350
----------	----------

• Components

Title	Part No.	Number	Manufacturer	Note
Connector	10150-3000PE	1	Sumitomo 3M	For Connector X4 (50-pins)
Connector cover	10350-52A0-008	1	(or equivalent)	

• Pin disposition (50 pins) (viewed from the soldering side)

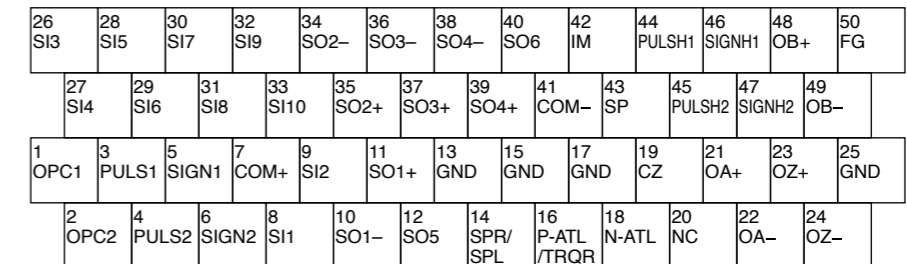

- 1) Check the stamped pin-No. on the connector body while making a wiring.
- 2) For the function of each signal title or its symbol, refer to the operating manual.
- 3) Do not connect anything to NC pins in the above table.

<Remarks>

• For crimp tool etc., necessary to produce a cable, access the web site of the manufacturer or consult with the manufacturer for details. For inquiries of manufacturer, refer to P.213 "List of Peripheral Equipments".

Connector Kit for External Scale (Excluding A5II E, A5E Series)

Part No. DV0PM20026

• Components

Title	Part No.	Manufacturer	Note
Connector	MUF-PK10K-X	J.S.T Mfg. Co., Ltd.	For Connector X5 (10-pins)

• Pin disposition of connector, connector X5

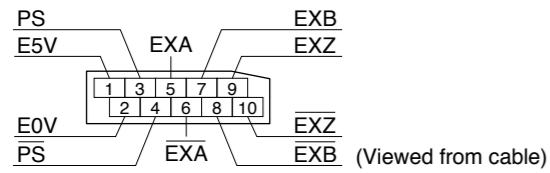

• Dimensions

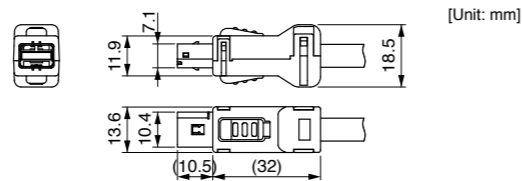

Connector Kit for Encoder

Part No. DV0PM20010

• Components

Title	Part No.	Manufacturer	Note
Connector (Driver side)	3E206-0100 KV	Sumitomo 3M (or equivalent)	For Connector X6
Shell kit	3E306-3200-008		

• Pin disposition of connector, connector X6

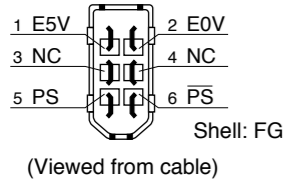

• Dimensions

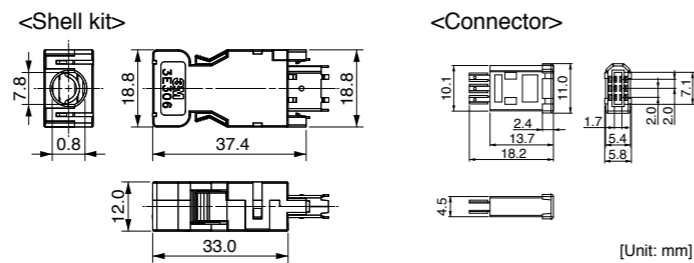

Connector Kit for Analog Monitor Signal

Part No. DV0PM20031

• Components

Title	Part No.	Number	Manufacturer	Note
Connector	510040600	1	Molex Inc	For Connector X7 (6-pins)
Connector pin	500118100	6		

• Pin disposition of connector, connector X7

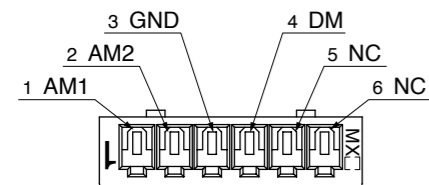

• Dimensions

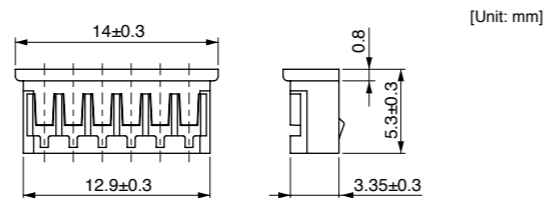

<Remarks>

Connector X1: use with commercially available cable.

• Configuration of connector X1: USB mini-B

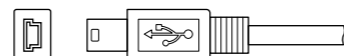

Connector Kit for Power Supply Input

Part No. DV0PM20032 (For A to C-frame 100 V, A to D-frame 200 V: Single row type)

• Components

Title	Part No.	Number	Manufacturer	Note
Connector	05JFAT-SAXGF	1	J.S.T Mfg. Co., Ltd.	For Connector XA
Handle lever	J-FAT-OT	2		

Part No. DV0PM20033 (For A to D-frame 200 V: Double row type)

• Components

Title	Part No.	Number	Manufacturer	Note
Connector	05JFAT-SAXGSA-C	1	J.S.T Mfg. Co., Ltd.	For Connector XA
Handle lever	J-FAT-OT	2		

• Dimensions

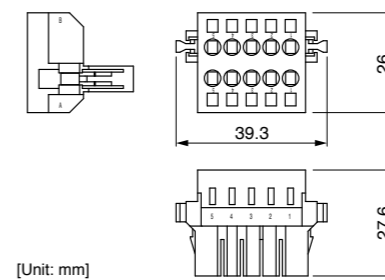

\* When connection multiple axes in series, make sure the sum of the current value does not exceed the rated current (11.25 A) of DV0PM20033.

Remarks

When using drivers MDDKT5540 \*\*\* or MDDHT5540 \*\*\* in single-phase power supply, do not use DV0PM20033.

Driver part No.	Power supply	Rated input current
MADHT1105 ***	Single phase 100 V	1.7 A
MADKT1105 ***	100 V	
MADHT1107 ***	Single phase 100 V	2.6 A
MADKT1107 ***	100 V	
MADHT1505 ***	Single phase/3-phase 200 V	1.6 A/0.9 A
MADKT1505 ***	200 V	
MADHT1507 ***	Single phase/3-phase 200 V	2.4 A/1.3 A
MADKT1507 ***	200 V	
MBDHT2110 ***	Single phase 100 V	4.3 A
MBDKT2110 ***	100 V	
MBDHT2510 ***	Single phase/3-phase 200 V	4.1 A/2.4 A
MBDKT2510 ***	200 V	
MCDHT3120 ***	Single phase 100 V	7.6 A
MCDKT3120 ***	100 V	
MCDHT3520 ***	Single phase/3-phase 200 V	6.6 A/3.6 A
MCDKT3520 ***	200 V	
MDDHT3530 ***	Single phase/3-phase 200 V	9.1 A/5.2 A
MDDKT3530 ***	200 V	
MDDHT5540 ***	Single phase/3-phase 200 V	14.2 A/8.1 A
MDDKT5540 ***	200 V	

Part No. DV0PM20044 (For E-frame 200 V)

• Components

Title	Part No.	Number	Manufacturer	Note
Connector	05JFAT-SAXGSA-L	1	J.S.T Mfg. Co., Ltd.	For Connector XA
Handle lever	J-FAT-OT-L	2		

Part No. DV0PM20051 (For D-frame 400 V)

• Components

Title	Part No.	Number	Manufacturer	Note
Connector	03JFAT-SAYGSA-M	1	J.S.T Mfg. Co., Ltd.	For Connector XA
Handle lever	J-FAT-OT-L	2		

Part No. DV0PM20052 (For E-frame 400 V)

• Components

Title	Part No.	Number	Manufacturer	Note
Connector	03JFAT-SAYGSA-L	1	J.S.T Mfg. Co., Ltd.	For Connector XA
Handle lever	J-FAT-OT-L	2		

Connector Kit for Control Power Supply Input

Part No.	DV0PM20053 (For D, E-frame 400 V)
----------	-----------------------------------

• Components

Title	Part No.	Number	Manufacturer	Note
Connector	02MJFAT-SAGF	1	J.S.T Mfg. Co., Ltd.	For Connector XD
Handle lever	MJFAT-0T	1		

Connector Kit for Regenerative Resistor Connection (E-frame)

Part No.	DV0PM20045 (For E-frame 200 V/400 V)
----------	--------------------------------------

• Components

Title	Part No.	Number	Manufacturer	Note
Connector	04JFAT-SAXGSA-L	1	J.S.T Mfg. Co., Ltd.	For Connector XC * Jumper wire is included.
Handle lever	J-FAT-OT-L	2		

Part No.	DV0PM20055 (For D-frame 400 V)
----------	--------------------------------

• Components

Title	Part No.	Number	Manufacturer	Note
Connector	04JFAT-SAXGSA-M	1	J.S.T Mfg. Co., Ltd.	For Connector XC
Handle lever	J-FAT-OT-L	2		

Connector Kit for Motor Connection (Driver side)

Part No.	DV0PM20034 (For A to C-frame 100 V, A to D-frame 200 V)
----------	---

• Components

Title	Part No.	Number	Manufacturer	Note
Connector	06JFAT-SAXGF	1	J.S.T Mfg. Co., Ltd.	For Connector XB * Jumper wire is included.
Handle lever	J-FAT-OT	2		

Part No.	DV0PM20046 (For E-frame 200 V/400 V)
----------	--------------------------------------

• Components

Title	Part No.	Number	Manufacturer	Note
Connector	03JFAT-SAXGSA-L	1	J.S.T Mfg. Co., Ltd.	For Connector XB
Handle lever	J-FAT-OT-L	2		

Part No.	DV0PM20054 (For D-frame 400 V)
----------	--------------------------------

• Components

Title	Part No.	Number	Manufacturer	Note
Connector	03JFAT-SAXGSA-M	1	J.S.T Mfg. Co., Ltd.	For Connector XB
Handle lever	J-FAT-OT-L	2		

Connector Kit

\* When IP65 or IP67 are necessary, the customer must give appropriate processing.

Connector Kit for Motor/Encoder Connection

Part No.	DV0P4290	Applicable model	MSMD 50 W to 750 W, MHMD 200 W to 750 W (absolute encoder type)
----------	----------	------------------	---

• Components

Title	Part No.	Number	Manufacturer	Note
Connector (Driver side)	3E206-0100 KV	1	Sumitomo 3M (or equivalent)	For Connector X6 (6-pins)
Shell kit	3E306-3200-008	1		
Connector	172161-1	1	Tyco Electronics	For Encoder cable (9-pins)
Connector pin	170365-1	9		
Connector	172159-1	1	Tyco Electronics	For Motor cable (4-pins)
Connector pin	170366-1	4		

• Pin disposition of connector, connector X6

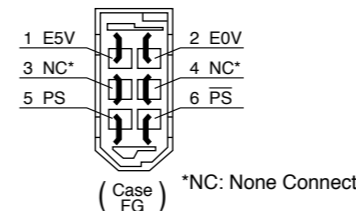

• Pin disposition of connector for encoder cable

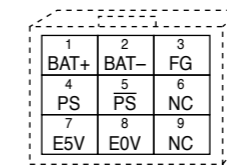

• Pin disposition of connector for motor cable

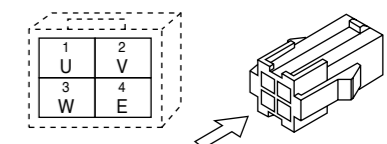

\* When you connect the battery for absolute encoder, refer to P.207, "When you make your own cable for 17-bit absolute encoder"

Part No.	DV0P4380	Applicable model	MSMD 50 W to 750 W, MSMJ 200 W to 750 W, MHMD 200 W to 750 W, MHMJ 200 W to 750 W (incremental encoder type)
----------	----------	------------------	--

• Components

Title	Part No.	Number	Manufacturer	Note
Connector (Driver side)	3E206-0100 KV	1	Sumitomo 3M (or equivalent)	For Connector X6 (6-pins)
Shell kit	3E306-3200-008	1		
Connector	172160-1	1	Tyco Electronics	For Encoder cable (6-pins)
Connector pin	170365-1	6		
Connector	172159-1	1	Tyco Electronics	For Motor cable (4-pins)
Connector pin	170366-1	4		

• Pin disposition of connector, connector X6

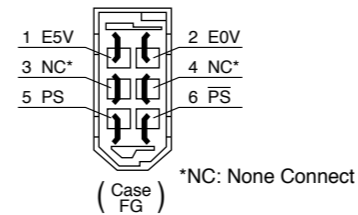

• Pin disposition of connector for encoder cable

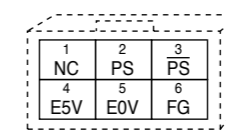

• Pin disposition of connector for motor cable

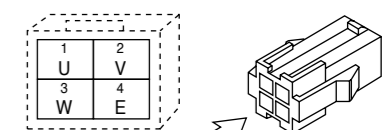

Connector Kit

\* When IP65 or IP67 are necessary, the customer must give appropriate processing.

Part No.	DV0PM20035	Applicable model	MSME 50 W to 400 W(100 V), 50 W to 750 W(200 V)
----------	------------	------------------	---

• Components

Title	Part No.	Number	Manufacturer	Note
Connector (Driver side)	3E206-0100 KV	1	Sumitomo 3M	For Connector X6 (6-pins)
Shell kit	3E306-3200-008	1	(or equivalent)	
Encoder connector	JN6FR07SM1	1	Japan Aviation Electronics Ind.	For Encoder cable (7-pins)
Socket contact	LY10-C1-A1-10000	7		
Motor connector	JN8FT04SJ1	1	Japan Aviation Electronics Ind.	For Motor cable (4-pins)
Socket contact	ST-TMH-S-C1B-3500	4		

- Pin disposition of connector, connector X6
- Pin disposition of connector for encoder cable
- Pin disposition of connector for motor cable

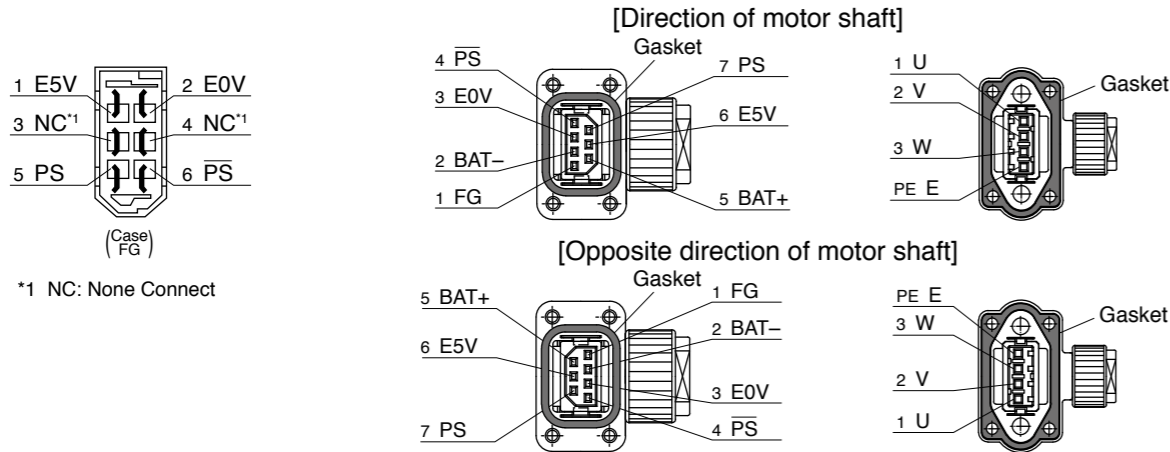

\*1 NC: None Connect

\* Pins 2 and 5 are left unused (NC) with an incremental encoder.

**Remarks** Secure the gasket in place without removing it from the connector. Otherwise, the degree of protection of IP67 will not be guaranteed.

Part No.	DV0PM20036	Applicable model	<IP67 motor> MSME 750 W (400 V), 1.0 kW to 2.0 kW, MDME 400 W (400 V), 600 W (400 V), 1.0 kW to 2.0 kW MHME 1.0 kW to 1.5 kW, MGME 0.9 kW (All model 200 V and 400 V commonness)	Without brake
----------	------------	------------------	--	---------------

• Components

Title	Part No.	Number	Manufacturer	Note
Connector (Driver side)	3E206-0100 KV	1	Sumitomo 3M	For Connector X6 (6-pins)
Shell kit	3E306-3200-008	1	(or equivalent)	
Encoder connector	JN2DS10SL1-R	1	Japan Aviation Electronics Ind.	For Encoder cable
Connector pin	JN1-22-22S-PKG100	5		
Motor connector	JL04V-6A-20-4SE-EB-R	1	Japan Aviation Electronics Ind.	For Motor cable
Cable clamp	JL04-2022CK(14)-R	1		

<Remarks>

• For crimp tool etc., necessary to produce a cable, access the web site of the manufacturer or consult with the manufacturer for details. For inquiries of manufacturer, refer to P.213 "List of Peripheral Equipments".

Part No.	DV0P4310	Applicable model	<IP65 motor> MSME 1.0 kW to 2.0 kW, MDME 1.0 kW to 2.0 kW MHME 1.0 kW to 1.5 kW, MGME 0.9 kW	Without brake
----------	----------	------------------	--	---------------

• Components

Title	Part No.	Number	Manufacturer	Note
Connector (Driver side)	3E206-0100 KV	1	Sumitomo 3M	For Connector X6 (6-pins)
Shell kit	3E306-3200-008	1	(or equivalent)	
Encoder connector	N/MS3106B20-29S	1	Japan Aviation Electronics Ind.	For Encoder cable
Cable clamp	N/MS3057-12A	1		
Motor connector	N/MS3106B20-4S	1	Japan Aviation Electronics Ind.	For Motor cable
Cable clamp	N/MS3057-12A	1		

Part No.	DV0PM20037	Applicable model	<IP67 motor> MSME 3.0 kW to 5.0 kW, MDME 3.0 kW to 5.0 kW MHME 2.0 kW to 5.0 kW, MGME 2.0 kW to 4.5 kW (All model 200 V and 400 V commonness)	Without brake
----------	------------	------------------	--	---------------

• Components

Title	Part No.	Number	Manufacturer	Note
Connector (Driver side)	3E206-0100 KV	1	Sumitomo 3M	For Connector X6 (6-pins)
Shell kit	3E306-3200-008	1	(or equivalent)	
Encoder connector	JN2DS10SL1-R	1	Japan Aviation Electronics Ind.	For Encoder cable
Connector pin	JN1-22-22S-PKG100	5		
Motor connector	JL04V-6A22-22SE-EB-R	1	Japan Aviation Electronics Ind.	For Motor cable
Cable clamp	JL04-2022CK(14)-R	1		

Part No.	DV0P4320	Applicable model	<IP65 motor> MSME 3.0 kW to 5.0 kW, MDME 3.0 kW to 5.0 kW MHME 2.0 kW to 5.0 kW, MGME 2.0 kW to 4.5 kW	Without brake
----------	----------	------------------	--	---------------

• Components

Title	Part No.	Number	Manufacturer	Note
Connector (Driver side)	3E206-0100 KV	1	Sumitomo 3M	For Connector X6 (6-pins)
Shell kit	3E306-3200-008	1	(or equivalent)	
Encoder connector	N/MS3106B20-29S	1	Japan Aviation Electronics Ind.	For Encoder cable
Cable clamp	N/MS3057-12A	1		
Motor connector	N/MS3106B22-22S	1	Japan Aviation Electronics Ind.	For Motor cable
Cable clamp	N/MS3057-12A	1		

Part No.	DV0PM20038	Applicable model	<IP67 motor> MSME 1.0 kW to 2.0 kW, MDME 1.0 kW to 2.0 kW MFME 1.5 kW (Common to with/ without brake), MHME 1.0 kW to 1.5 kW, MGME 0.9 kW (All model 200 V)	With brake
----------	------------	------------------	---	------------

• Components

Title	Part No.	Number	Manufacturer	Note
Connector (Driver side)	3E206-0100 KV	1	Sumitomo 3M	For Connector X6 (6-pins)
Shell kit	3E306-3200-008	1	(or equivalent)	
Encoder connector	JN2DS10SL1-R	1	Japan Aviation Electronics Ind.	For Encoder cable
Connector pin	JN1-22-22S-PKG100	5		
Motor connector	JL04V-6A20-18SE-EB-R	1	Japan Aviation Electronics Ind.	For Motor cable
Cable clamp	JL04-2022CK(14)-R	1		

Connector Kit

\* When IP65 or IP67 are necessary, the customer must give appropriate processing.

Part No.	DV0P4330	Applicable model	<IP65 motor> MSME 1.0 kW to 2.0 kW, MDME 1.0 kW to 2.0 kW MHME 1.0 kW to 1.5 kW, MGME 0.9 kW	With brake
----------	----------	------------------	--	------------

• Components

Title	Part No.	Number	Manufacturer	Note
Connector (Driver side)	3E206-0100 KV	1	Sumitomo 3M (or equivalent)	For Connector X6 (6-pins)
Shell kit	3E306-3200-008	1		
Encoder connector	N/MS3106B20-29S	1	Japan Aviation Electronics Ind.	For Encoder cable
Cable clamp	N/MS3057-12A	1		
Motor connector	N/MS3106B20-18S	1	Japan Aviation Electronics Ind.	For Motor cable
Cable clamp	N/MS3057-12A	1		

Part No.	DV0PM20039	Applicable model	<IP67 motor> (200V) MSME 3.0 kW to 5.0 kW, MDME 3.0 kW to 5.0 kW MFME 2.5 kW to 4.5 kW (Common to with/ without brake), MHME 2.0 kW to 5.0 kW, MGME 2.0 kW to 4.5 kW (400V) MSME 750 W to 5.0 kW, MDME 400 W to 5.0 kW MFME 1.5 kW to 4.5 kW (Common to with/ without brake), MHME 1.0 kW to 5.0 kW, MGME 0.9 kW to 4.5 kW	With brake
----------	------------	------------------	--	------------

• Components

Title	Part No.	Number	Manufacturer	Note
Connector (Driver side)	3E206-0100 KV	1	Sumitomo 3M (or equivalent)	For Connector X6 (6-pins)
Shell kit	3E306-3200-008	1		
Encoder connector	JN2DS10SL1-R	1	Japan Aviation Electronics Ind.	For Encoder cable
Connector pin	JN1-22-22S-PKG100	5		
Motor connector	JL04V-6A24-11SE-EB-R	1	Japan Aviation Electronics Ind.	For Motor cable
Cable clamp	JL04-2428CK(17)-R	1		

Part No.	DV0P4340	Applicable model	<IP65 motor> MSME 3.0 kW to 5.0 kW, MDME 3.0 kW to 5.0 kW MHME 2.0 kW to 5.0 kW, MGME 2.0 kW to 4.5 kW	With brake
----------	----------	------------------	--	------------

• Components

Title	Part No.	Number	Manufacturer	Note
Connector (Driver side)	3E206-0100 KV	1	Sumitomo 3M (or equivalent)	For Connector X6 (6-pins)
Shell kit	3E306-3200-008	1		
Encoder connector	N/MS3106B20-29S	1	Japan Aviation Electronics Ind.	For Encoder cable
Cable clamp	N/MS3057-12A	1		
Motor connector	N/MS3106B24-11S	1	Japan Aviation Electronics Ind.	For Motor cable
Cable clamp	N/MS3057-16A	1		

<Remarks>

- For crimp tool etc., necessary to produce a cable, access the web site of the manufacturer or consult with the manufacturer for details. For inquiries of manufacturer, refer to P.213 "List of Peripheral Equipments".

Part No.	DV0PM20056	Applicable model	<IP67 motor> MDME 7.5 kW to 15.0 kW MGME 6.0 kW, MHME 7.5 kW	Without brake
----------	------------	------------------	--	---------------

• Components

Title	Part No.	Number	Manufacturer	Note
Connector (Driver side)	3E206-0100 KV	1	Sumitomo 3M (or equivalent)	For Connector X6 (6-pins)
Shell kit	3E306-3200-008	1		
Encoder connector	JN2DS10SL1-R	1	Japan Aviation Electronics Ind.	For Encoder cable
Connector pin	JN1-22-22S-PKG100	5		
Motor connector	JL04V-6A32-17SE-EB-R	1	Japan Aviation Electronics Ind.	For Motor cable
Cable clamp	JL04-32CK(24)-R	1		

\* Cable cover size: Φ22 to Φ25. Cable core material is not specified. The user can select the cable compatible with the connector to be used.

Part No.	DV0PM20057	Applicable model	<IP67 motor> MDME 7.5 kW to 15.0 kW MGME 6.0 kW, MHME 7.5 kW	With brake
----------	------------	------------------	--	------------

• Components

Title	Part No.	Number	Manufacturer	Note
Connector (Driver side)	3E206-0100 KV	1	Sumitomo 3M (or equivalent)	For Connector X6 (6-pins)
Shell kit	3E306-3200-008	1		
Encoder connector	JN2DS10SL1-R	1	Japan Aviation Electronics Ind.	For Encoder cable
Connector pin	JN1-22-22S-PKG100	5		
Motor connector	JL04V-6A32-17SE-EB-R	1	Japan Aviation Electronics Ind.	For Motor cable
Cable clamp	JL04-32CK(24)-R	1		
Brake connector	N/MS3106B14S-2S	1	Japan Aviation Electronics Ind.	For Brake cable
Cable clamp	N/MS3057-6A	1		

\* Cable cover size: Φ22 to Φ25. Cable core material is not specified. The user can select the cable compatible with the connector to be used.

Connector Kit for Motor/Brake Connection

Part No.	DV0PM20040	Applicable model	MSME 50 W to 750 W
----------	------------	------------------	--------------------

• Components

Title	Part No.	Number	Manufacturer	Note
Connector	JN4FT02SJM-R	1	Japan Aviation Electronics Ind.	For brake cable
Socket contact	ST-TMH-S-C1B-3500	2		

• Pin disposition of connector for brake cable

[Direction of motor shaft]

[Opposite direction of motor shaft]

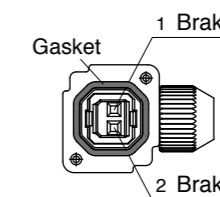
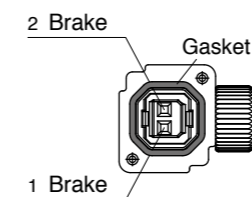

<Remarks>

Secure the gasket in place without removing it from the connector. Otherwise, the degree of protection of IP67 will not be guaranteed.

<Remarks>

- For crimp tool etc., necessary to produce a cable, access the web site of the manufacturer or consult with the manufacturer for details. For inquiries of manufacturer, refer to P.213 "List of Peripheral Equipments".



Battery for Absolute Encoder

Part No. DV0P2990

• Lithium battery: 3.6 V 2000 mAh

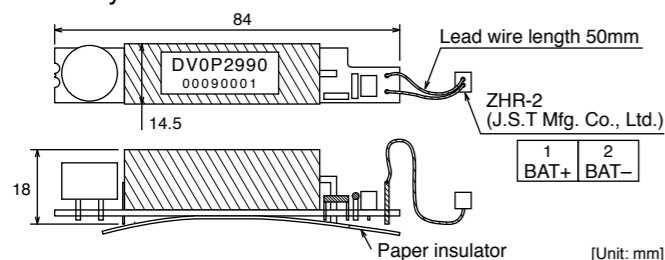

<Caution>

This battery is categorized as hazardous substance, and you may be required to present an application of hazardous substance when you transport by air (both passenger and cargo airlines).

Battery Box for Absolute Encoder

Part No. DV0P4430

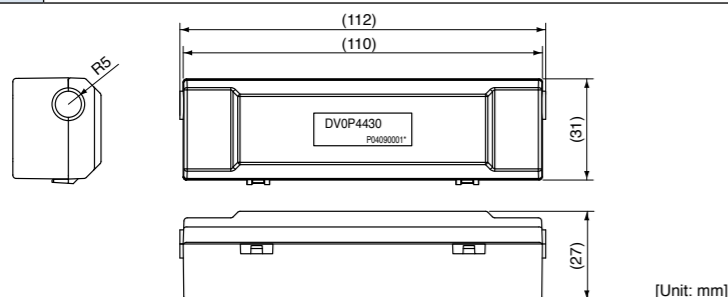

When making a cable for 17-bit absolute encoder by yourself

When you make your own cable for 17-bit absolute encoder, connect the optional battery for absolute encoder, DV0P2990 as per the wiring diagram below. Connector of the battery for absolute encoder shall be provided by customer as well.

<Caution>

Install and fix the battery securely. If the installation and fixing of the battery is not appropriate, it may cause the wire breakdown or damage of the battery. Refer to the instruction manual of the battery for handling the battery.

• Installation Place of Battery

- 1) Indoors, where the products are not subjected to rain or direct sun beam.
- 2) Where the products are not subjected to corrosive atmospheres such as hydrogen sulfide, sulfurous acid, chlorine, ammonia, chloric gas, sulfuric gas, acid, alkaline and salt and so on, and are free from splash of inflammable gas, grinding oil, oil mist, iron powder or chips and etc.
- 3) Well-ventilated and humid and dust-free place.
- 4) Vibration-free place

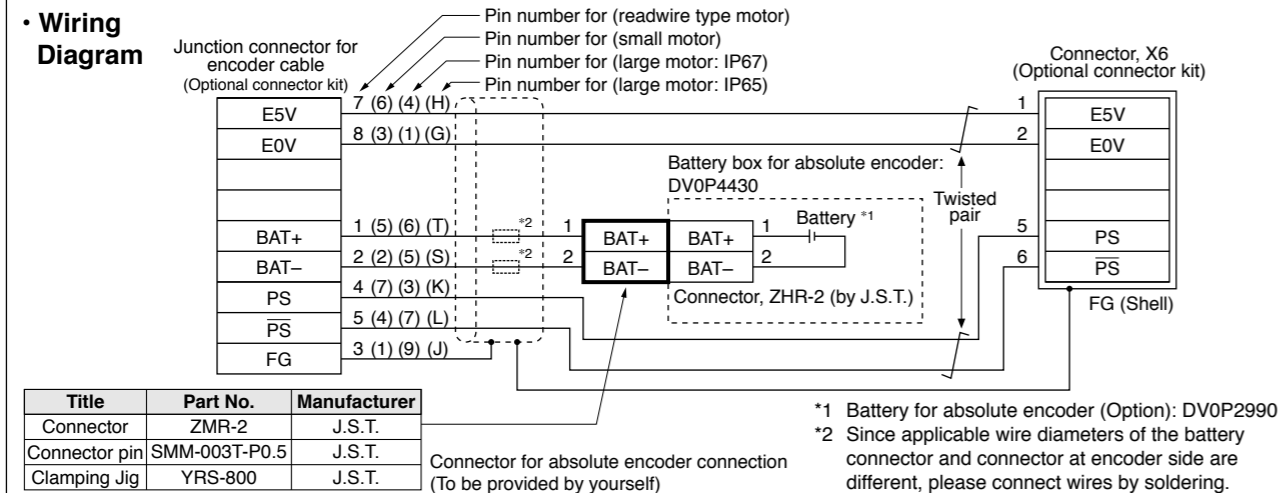

Mounting Bracket

Part No.	DV0PM20027	Frame symbol of applicable driver	A-frame	Mounting screw	M4 x L6 Pan head	4pcs
----------	------------	-----------------------------------	---------	----------------	------------------	------

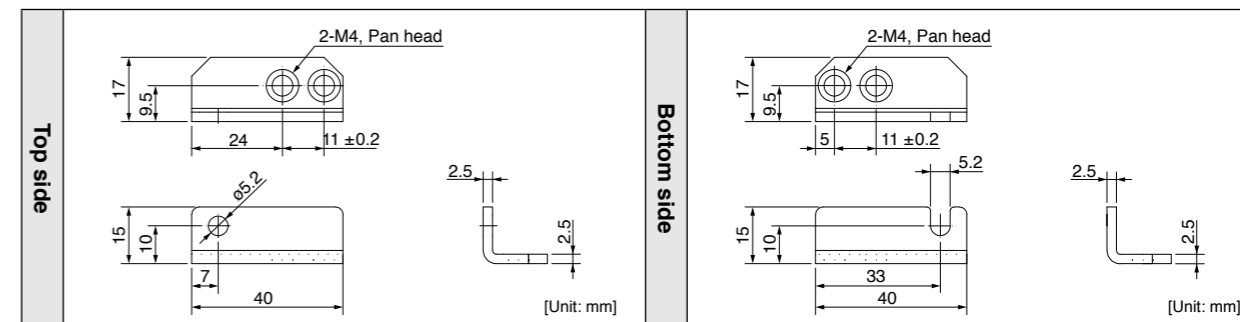

Part No.	DV0PM20028	Frame symbol of applicable driver	B-frame	Mounting screw	M4 x L6 Pan head	4pcs
----------	------------	-----------------------------------	---------	----------------	------------------	------

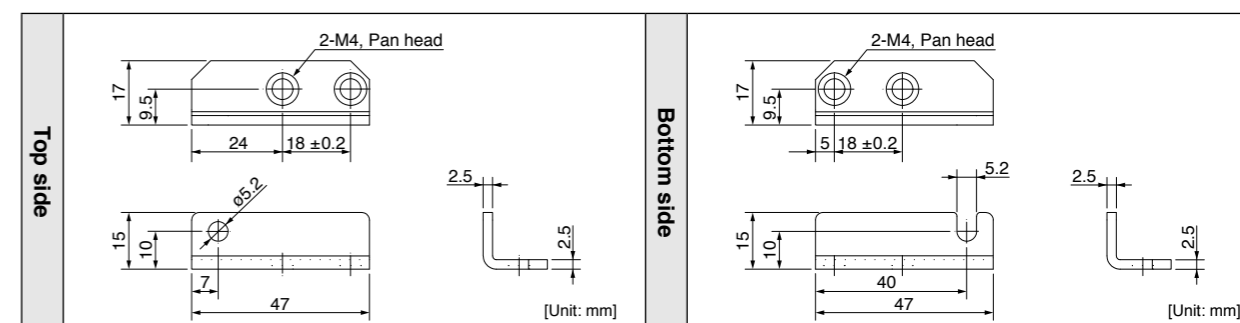

Part No.	DV0PM20029	Frame symbol of applicable driver	C-frame	Mounting screw	M4 x L6 Pan head	4pcs
----------	------------	-----------------------------------	---------	----------------	------------------	------

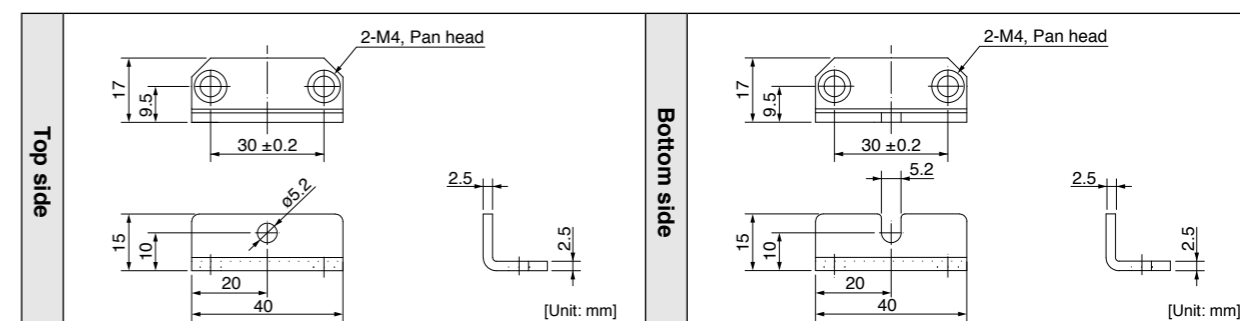

Part No.	DV0PM20030	Frame symbol of applicable driver	D-frame	Mounting screw	M4 x L6 Pan head	4pcs
----------	------------	-----------------------------------	---------	----------------	------------------	------

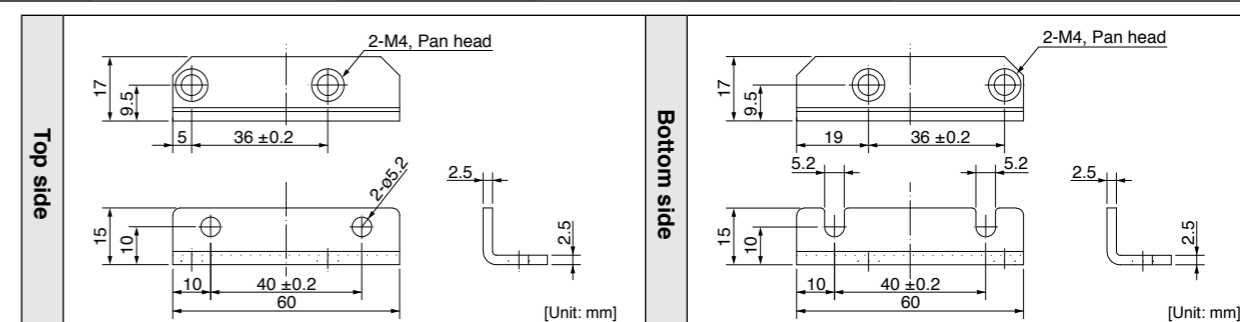

<Caution>

For E, F and G-frame, it is possible to make both a front end and back end mounting by changing the mounting direction of L-shape bracket (attachment).

Fig.1

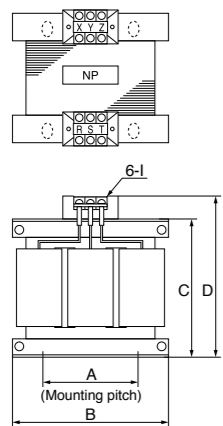

• Wiring of the reactor <3-Phase>

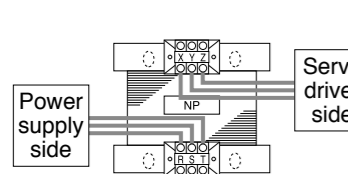
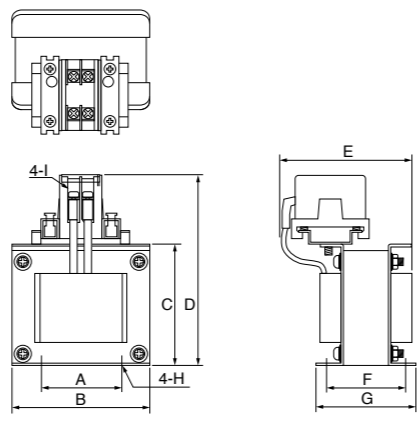
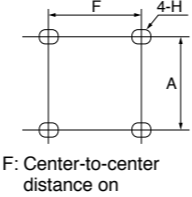
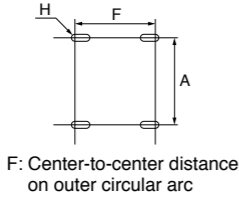
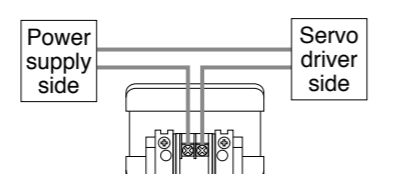

Fig.2



• Wiring of the reactor <Single phase>



[Unit: mm]

	Part No.	A	B	C	D	E(Max)	F	G	H	I	Inductance (mH)	Rated current (A)
Fig.1	DV0P220	65±1	125±1	(93)	136 <sub>Max</sub>	155	70+3/-0	85±2	4-7φ×12	M4	6.81	3
	DV0P221	60±1	150±1	(113)	155 <sub>Max</sub>	130	60+3/-0	75±2	4-7φ×12	M4	4.02	5
	DV0P222	60±1	150±1	(113)	155 <sub>Max</sub>	140	70+3/-0	85±2	4-7φ×12	M4	2	8
	DV0P223	60±1	150±1	(113)	155 <sub>Max</sub>	150	79+3/-0	95±2	4-7φ×12	M4	1.39	11
	DV0P224	60±1	150±1	(113)	160 <sub>Max</sub>	155	84+3/-0	100±2	4-7φ×12	M5	0.848	16
	DV0P225	60±1	150±1	(113)	160 <sub>Max</sub>	170	100+3/-0	115±2	4-7φ×12	M5	0.557	25
Fig.2	DV0P227	55±0.7	80±1	66.5±1	110 <sub>Max</sub>	90	41±2	55±2	4-5φ×10	M4	4.02	5
	DV0P228	55±0.7	80±1	66.5±1	110 <sub>Max</sub>	95	46±2	60±2	4-5φ×10	M4	2	8
	DV0PM20047	55±0.7	80±1	66.5±1	110 <sub>Max</sub>	105	56±2	70±2	4-5φ×10	M4	1.39	11

\* For application, refer to P.21 to P.28 and P.153 to P.154 "Table of Part Numbers and Options".

**Harmonic restraint**

Harmonic restraint measures are not common to all countries. Therefore, prepare the measures that meet the requirements of the destination country.

With products for Japan, on September, 1994, "Guidelines for harmonic restraint on heavy consumers who receive power through high voltage system or extra high voltage system" and "Guidelines for harmonic restraint on household electrical appliances and general-purpose articles" established by the Agency for Natural Resources and Energy of the Ministry of Economy, Trade and Industry (the ex-Ministry of International Trade and Industry). According to those guidelines, the Japan Electrical Manufacturers' Association (JEMA) have prepared technical documents (procedure to execute harmonic restraint: JEM-TR 198, JEM-TR 199 and JEM-TR 201) and have been requesting the users to understand the restraint and to cooperate with us. On January, 2004, it has been decided to exclude the general-purpose inverter and servo driver from the "Guidelines for harmonic restraint on household electrical appliances and general-purpose articles". After that, the "Guidelines for harmonic restraint on household electrical appliances and general-purpose articles" was abolished on September 6, 2004.

We are pleased to inform you that the procedure to execute the harmonic restraint on general-purpose inverter and servo driver was modified as follows.

- All types of the general-purpose inverters and servo drivers used by specific users are under the control of the "Guidelines for harmonic restraint on heavy consumers who receive power through high voltage system or extra high voltage system". The users who are required to apply the guidelines must calculate the equivalent capacity and harmonic current according to the guidelines and must take appropriate countermeasures if the harmonic current exceeds a limit value specified in a contract demand. (Refer to JEM-TR 210 and JEM-TR 225.)
- The "Guidelines for harmonic restraint on household electrical appliances and general-purpose articles" was abolished on September 6, 2004. However, based on conventional guidelines, JEMA applies the technical documents JEM-TR 226 and JEM-TR 227 to any users who do not fit into the "Guidelines for harmonic restraint on heavy consumers who receive power through high voltage system or extra high voltage system" from a perspective on enlightenment on general harmonic restraint. The purpose of these guidelines is the execution of harmonic restraint at every device by a user as usual to the utmost extent.

<Remarks> When using a reactor, be sure to install one reactor to one servo driver.

Part No.	Manufacturer's part No.	Specifications					Activation temperature of built-in thermostat	
		Resistance	cable core outside diameter	Weight	Rated power (reference) *1			
					Free air	with fan 1 m/s		
Ω	mm	kg	W	W				
DV0P4280	RF70M	50	φ1.27 (AWG18 stranded wire)	0.1	10	25	140±5 °C B-contact Open/Close capacity (resistance load) 1 A 125 VAC 6000 times 0.5 A 250 VAC 10000 times	
DV0P4281	RF70M	100		0.1	10	25		
DV0P4282	RF180B	25		0.4	17	50		
DV0P4283	RF180B	50		0.2	17	50		
DV0P4284	RF240	30		0.5	40	100		
DV0P4285	RH450F	20		1.2	52	130		
DV0PM20048	RF240	120		0.5	35	80		
DV0PM20049	RH450F	80		1.2	65	190		
DV0PM20058	RH450F × 6	3.3		— *2	16	— *3		780
DV0PM20059	RH450F × 6	13.3		— *2	16	— *3		1140

Manufacturer : Iwaki Musen Kenkyusho

\*1 Power with which the driver can be used without activating the built-in thermostat.

A built-in thermal fuse and a thermal protector are provided for safety.

The circuit should be so designed that the power supply will be turned off as the thermal protector operates.

The built-in thermal fuse blows depending on changes in heat dissipation condition, operating temperature limit, power supply voltage or load.

Mount the regenerative resistor on a machine operating under aggressive regenerating condition (high power supply voltage, large load inertia, shorter deceleration time, etc.) and make sure that the surface temperature will not exceed 100 °C.

Attach the regenerative resistor to a nonflammable material such as metal.

Cover the regenerative resistor with a nonflammable material so that it cannot be directly touched.

Temperatures of parts that may be directly touched by people should be kept below 70 °C.

\*2 Terminal block with screw tightening torque as shown below.

T1, T2, 24 V, 0 V, E : M4 : 1.2 N·m to 1.4 N·m

R1, R2 : M5 : 2.0 N·m to 2.4 N·m

Use the cable with the same diameter as the main circuit cable. (Refer to P.19).

\*3 With built-in fan which should always be operated with the power supply connected across 24 V and 0 V.

Frame	Power supply		
	Single phase, 100 V	Single phase, 200 V 3-phase, 200 V	3-phase, 400 V
A	DV0P4280	DV0P4281 (50 W, 100 W) DV0P4283 (200 W)	—
B	DV0P4283	DV0P4283	
C	DV0P4282	DV0P4283	
D		DV0P4284	DV0PM20048
E		DV0P4284 × 2 in parallel or DV0P4285	DV0PM20049
F	—	DV0P4285 × 2 in parallel	DV0PM20049 × 2 in parallel
G		DV0P4285 × 3 in parallel	DV0PM20049 × 3 in parallel
H		DV0P4285 × 6 in parallel or DV0PM20058	DV0PM20049 × 6 in parallel or DV0PM20059

DV0P4280, DV0P4281

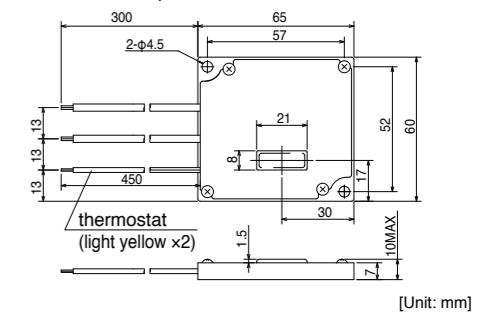

DV0P4282, DV0P4283

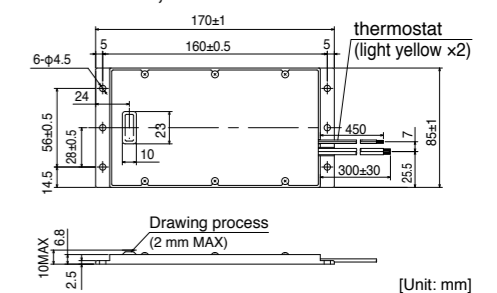

DV0P4284, DV0PM20048

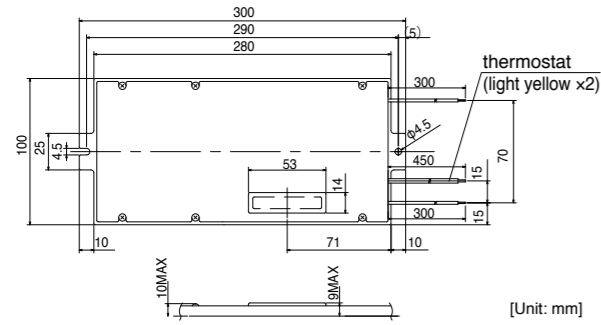

DV0P4285, DV0PM20049

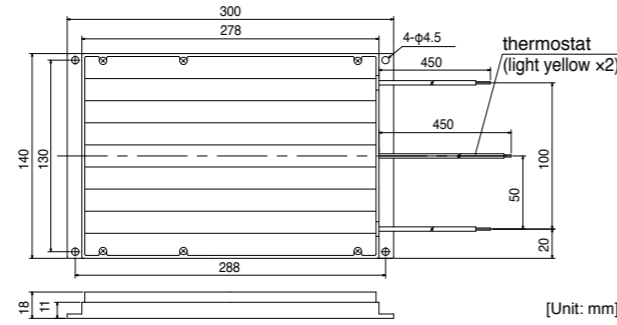

DV0PM20058, DV0PM20059

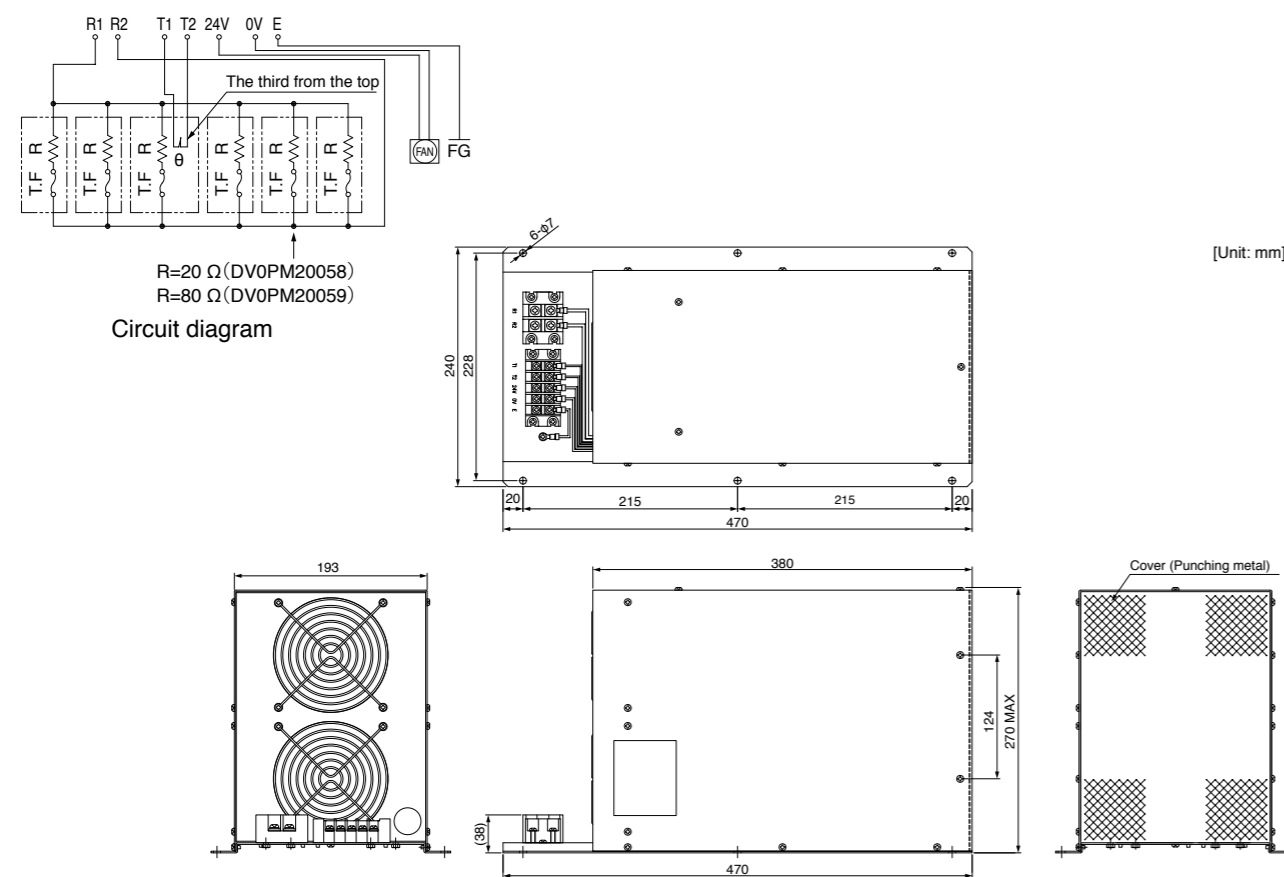

<Remarks>

Thermal fuse is installed for safety. Compose the circuit so that the power will be turned off when the thermostat is activated. The thermal fuse may blow due to heat dissipating condition, working temperature, supply voltage or load fluctuation.

Make it sure that the surface temperature of the resistor may not exceed 100 °C at the worst running conditions with the machine, which brings large regeneration (such case as high supply voltage, load inertia is large or deceleration time is short) Install a fan for a forced cooling if necessary.

<Caution>

Regenerative resistor gets very hot.

Take preventive measures for fire and burns.  
Avoid the installation near inflammable objects, and easily accessible place by hand.

Motor	Part No.	Manufacturer	
MSMD	Z15D271 or TNR15G271K	SEMITEC Corporation or NIPPON CHEMI-CON CORPORATION	
MSMJ			
MSME	Z15D151	SEMITEC Corporation	
			50 W to 750 W 750 W (400 V) 1.0 kW to 5.0 kW
MDME	NVD07SCD082	KOA Corporation	
			400 W (400 V), 600 W (400 V)
			1.0 kW to 3.0 kW
MFME	NVD07SCD082	KOA Corporation	
			4.0 kW to 7.5 kW 11 kW, 15 kW
MGME	Z15D151	SEMITEC Corporation	
MHMD MHMJ	Z15D271 or TNR15G271K	SEMITEC Corporation or NIPPON CHEMI-CON CORPORATION	
MHME	Z15D151	SEMITEC Corporation	
			1.0 kW, 1.5 kW 2.0 kW to 7.5 kW



# Compact Servo Only for Position Control.

Ultra compact  
position control type

## MINAS E Series

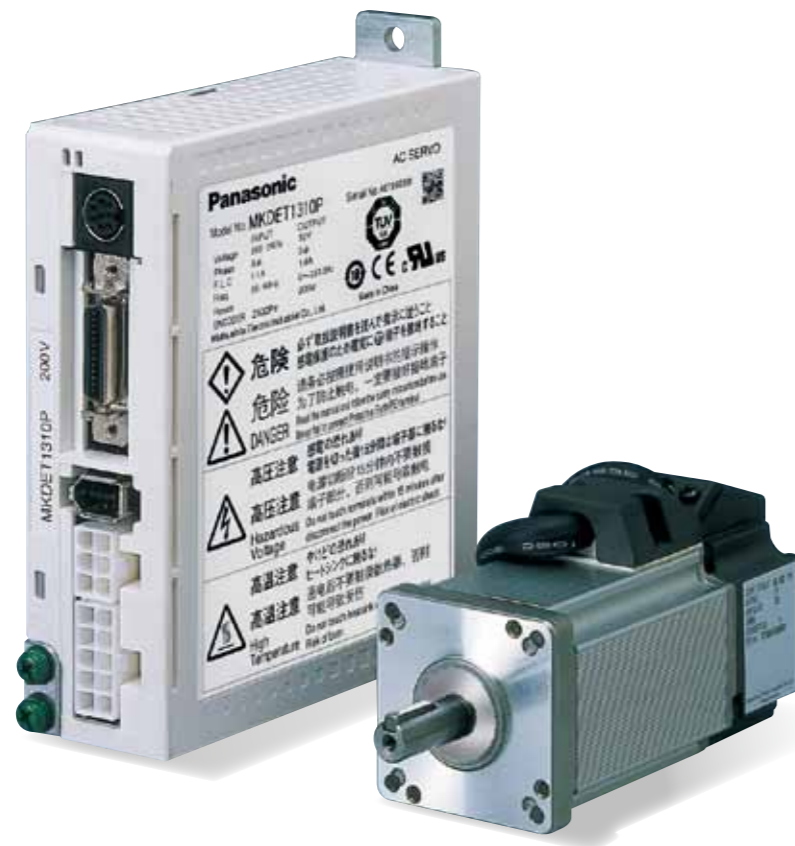

### 1 Best Fit to Small Drives

- Further evolution in down-sizing, by 47 % in size. (Note)
- Exclusively designed for position control.

(Note) Compared to MUDS043A1

### 2 Easy to Handle, Easy to Use

- DIN-rail mounting unit (option) improves handling/installation.
- User-friendly Console makes the setup easy.
- High functionality Real-Time Auto-Gain Tuning enables adjustment-free operation.



### 3 High-Speed Positioning with Resonance Suppression Filters

- Built-in notch filter suppresses resonance of the machine.
- Built-in adaptive filter detect resonance frequency and suppress vibration.

### 4 Smoother operation for Low Stiffness Machine

- Damping control function suppresses vibration during acceleration/deceleration

## Contents

<b>Features</b> .....	215
<b>Motor Line-up</b> .....	219
<b>Model Designation</b> .....	220
<b>Overall Wiring</b> .....	221
<b>Driver and List of Applicable Peripheral Equipments</b> .....	221
<b>Driver</b> .....	223
Driver Specifications.....	223
Standard Wiring Example of Main Circuit.....	224
Encoder Wiring Diagram.....	224
Control Circuit Standard Wiring Example.....	225
Dimensions of Driver.....	226
<b>Motor</b> .....	227
Specifications/Model designation/Torque Characteristics.....	227
Dimensions of Moter.....	231
Motors with Gear Reducer.....	232
<b>Options</b> .....	236
Setup Support Software.....	236
Cable part No. Designation.....	237
Cable Set.....	238
Encoder Cable.....	238
Motor Cable.....	238
Brake Cable.....	238
Connector Kit.....	239
Interface Cable.....	241
Communication Cable.....	241
Console.....	241
DIN Rail Mounting Unit.....	242
External Regenerative Resistor.....	242
Reactor.....	243
Surge Absorber for Motor Brake.....	243
List of Peripheral Components.....	244

# 1. Easy to Handle, Easy to Use

## High-functionality Real-Time Auto-Gain Tuning (Note 1)

- Offers real automatic gain tuning for low and high stiffness machines with a combination of an adaptive filter.
- Supports the vertical axis application where the load torque is different in rotational direction.

## DIN-rail mounting unit (option)

- DIN-rail mounting unit allows parallel mounting with small control devices such as PLC.
- Easy to mount and easy to dismount.

# 2. Further Reduction of Vibration

## Adaptive filter (Note1)

- Makes the notch filter frequency automatically follow the machine resonance frequency in real-time auto-gain tuning.
- Suppression of "Judder" noise of the machine, which is caused by variation of the machines or resonance frequency due to aging, can be expected.

## Notch filter (Note1)

- 1-channel notch filter is equipped in the driver independent from adaptive filter.
- Each of 2 filters can set up frequency and notch width, and frequency in 1Hz unit. Suppression of "Judder" noise of the machine which has multiple resonance points can be expected.

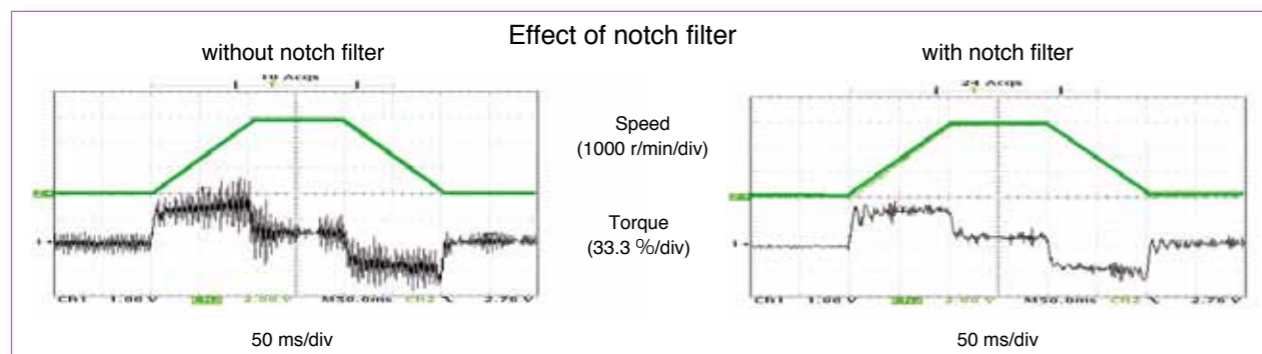

## Damping control (Note1)

- You can suppress vibration occurring at both starting and stopping in low stiffness machine, by manually setting up vibration frequency in 0.1 Hz unit. Note) Only applies to manual adjustment

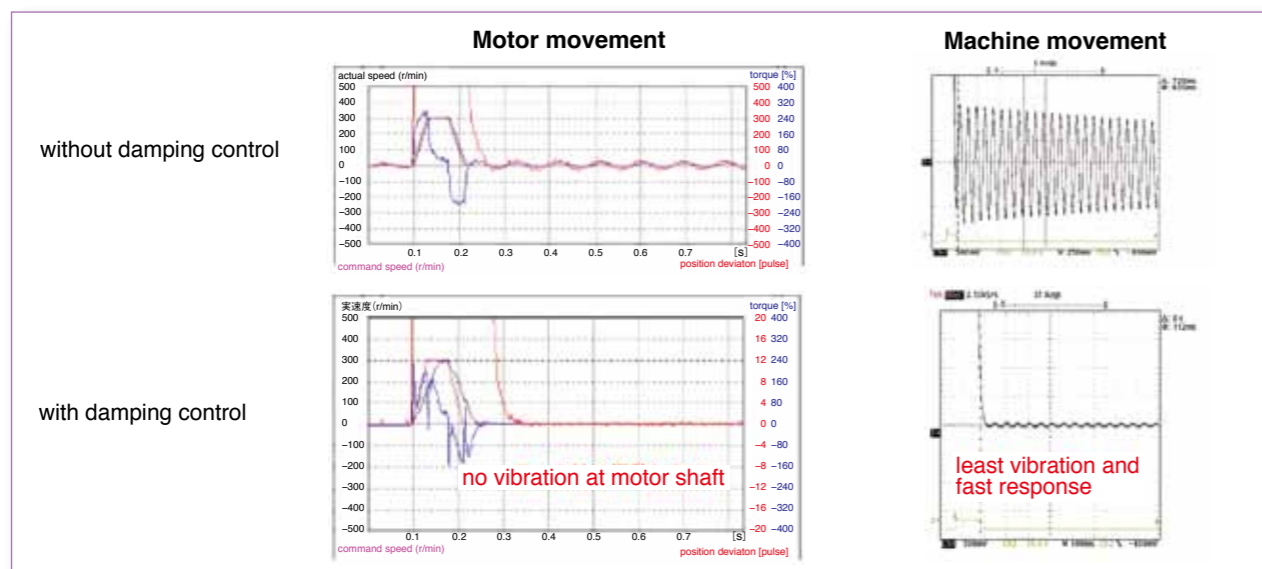

(Note1) Select at positioning action mode.  
 • At high speed positioning mode (Pr02=0) Select either one of notch filter, damping control or high-functionality real-time auto-gain tuning. Not possible to use them all at the same time. Adaptive filter cannot be used.  
 • At high-functionality positioning mode (Pr02=1) All of notch filter, damping control, high-functionality real-time auto-gain tuning and adaptive filter can be used at the same time.

# 3. Further Flexibility and Multiplicity

## Console (Option)

- You can set up parameters, copy and make a JOG run.
- Convenient for maintenance at site.
- Refer to P.241, Options.

## Command control modes

- Offers 2 command modes, "Position control" and "Internal velocity control".
- You can make a 4-speed running at preset values with parameter at internal velocity control mode.

## Inrush current suppressing function

- Inrush suppressing resistor, which prevent the circuit breaker shutdown of the power supply caused by inrush current at power-on, is equipped in this driver.
- Prevents unintentional shutdown of the power supply circuit breaker in multi axis application and does not give load to the power line.

## Regeneration discharging function

- Discharges the regenerative energy with external resistor, where energy is generated while stopping the load with large moment of inertia, or use in up-down operation, and is returned to the driver from the motor.
- No regenerative resistor is installed in the driver.
- It is highly recommended to install an external regenerative resistor (option).

## Built-in dynamic brake

- You can select the dynamic brake action which short the servo motor windings of U, V and W, at Servo-OFF, CW/CCW over-travel inhibition, power shutdown and trip.
- You can select the action sequence depending on the machine requirement.

## Setup support software (Option)

- With the setup support software, "PANATERM" via RS232 / RS485 communication port, you can monitor the running status of the driver and set up parameters. Note) Refer to P.236 for setup support software.

## Key-way shaft and tapped shaft end

- Easy pulley attachment and easy maintenance
- Attache screw to the tapped shaft to prevent key or pulley from being pulled out.

## Wave-form graphic function

- With the setup support software, "PANATERM", you can monitor the "Command speed", "Actual speed", "Torque", "Position deviation" and "Positioning complete signal".
- Helps you to analyze the machine and shorten the setup time. Note) Refer to P.236 for setup support software.

## Frequency analyzing function

- You can confirm the response frequency characteristics of total machine mechanism including the servo motor with the setup support software, "PANATERM".
- Helps you to analyze the machine and shorten the setup time. Note) Refer to P.236 for setup support software.

## Torque limit switching function

- You can select 2 preset torque limit value from external input.
- Use this function for tension control or press-hold control.

## Conformity to CE and UL Standards



Subject	Standard conformed	
Motor	IEC60034-1 IEC60034-5 UL1004 CSA22.2 No.100	Conforms to Low-Voltage Directives
	EN50178 UL508C CSA22.2 No.14	
Motor and driver	EN55011 Radio Disturbance Characteristics of Industrial, Scientific and Medical (ISM) Radio-Frequency Equipment	Conforms to references by EMC Directives
	EN61000-6-2 Immunity for Industrial Environments	
	EC61000-4-2 Electrostatic Discharge Immunity Test	
	IEC61000-4-3 Radio Frequency Electromagnetic Field Immunity Test	
	IEC61000-4-4 Electric High-Speed Transition Phenomenon/Burst Immunity Test	
	IEC61000-4-5 Lightning Surge Immunity Test	
	IEC61000-4-6 High Frequency Conduction Immunity Test	
IEC61000-4-11 Instantaneous Outage Immunity Test		

IEC : International Electrotechnical Commission  
 EN : Europäischen Normen  
 EMC : Electromagnetic Compatibility  
 UL : Underwriters Laboratories  
 CSA : Canadian Standards Association

Pursuant to at the directive 2004/108/EC, article 9(2)

Panasonic Testing Centre  
 Panasonic Service Europe,  
 a division of Panasonic Marketing Europe GmbH  
 Winsbergring 15,22525 Hamburg,F.R.Germany

\* When exporting this product, follow statutory provisions of the destination country.

Motor Line-up

Motor series	Rated output (kW)	Rated rotational speed (Max. speed) (r/min)	Rotary encoder		Brake	Gear	UL/CSA	Enclosure	Features	Applications
			2500 P/r incremental	17bit absolute/incremental	Holding	High precision				
<b>MUMA</b>  Ultra low inertia	<b>0.05 to 0.4</b>	3000 (5000)	○	—	○	○	○	IP65 Except shaft throughhole and connector	Small capacity Ultra low inertia	SMT machines Inserters High repetitive positioning application
	0.05									
	0.1									
	0.2									
0.4										

Model Designation

■ Servo Motor

**M U M A 5 A Z P 1 S \* \***

Symbol	Type
MUMA	Ultra low inertia (50 W to 400 W)

Motor rated output

Symbol	Rated output
5A	50 W
01	100 W
02	200 W
04	400 W

Voltage specifications

Symbol	Specifications
1	100 V
2	200 V
Z	100 V/200 V common (50 W only)

Rotary encoder specifications

Symbol	Format	Pulse counts	Resolution	Wires
P	Incremental	2500 P/r	10,000	5

Special specifications

Motor structure

Symbol	Shaft	Holding brake		Oil seal	
	Key-way, center tap	without	with	without	with*
S	●	●		●	
T	●		●	●	

\* Motor with oil seal is manufactured by order.

Design order

Symbol	Specifications
1	Standard

See P.227 for motor specifications

■ Motor with gear reducer

**M U M A 0 1 1 P 3 1 N**

Symbol	Type
MUMA	Ultra low inertia (100 W to 400 W)

Motor rated output

Symbol	Specifications
01	100 W
02	200 W
04	400 W

Voltage specifications

Symbol	Specifications
1	100 V
2	200 V

Rotary encoder specifications

Symbol	Format	Pulse counts	Resolution	Wires
P	Incremental	2500 P/r	10,000	5

Gear reduction ration, gear type

Symbol	Gear reduction ratio	Motor output (W)			Gear type
		100	200	400	
1N	1/5	●	●	●	For high accuracy
2N	1/9	●	●	●	
4N	1/25	●	●	●	

Motor structure

Symbol	Shaft	Holding brake	
	Key-way	without	with
3	●	●	
4	●		●

See P.232 for motor with gear reducer specifications

■ Servo Driver

**M K D E T 1 3 1 0 P \* \***

Frame symbol

Symbol	Frame
MKDE	E series, K-frame
MLDE	E series, L-frame

Power device Max. current rating

Symbol	Current rating
T1	10 A
T2	15 A

Supply voltage specifications

Symbol	Specifications
1	Single phase, 100 V
2	Single phase, 200 V
3	3-phase, 200 V
5	Single/3-phase, 200 V

Special specifications

Control mode

Symbol	Specifications
P	Pulse train

Current detector current rating

Symbol	Current rating
05	5 A
10	10 A

See P.223 for driver specifications

• Wiring of main circuit

**Circuit Breaker (MCCB)**  
Protects the power lines. Shuts off the circuit when overcurrent passes.

**Noise Filter (NF)**  
Prevents external noise from the power lines. And reduces an effect of the noise generated by the servo driver.

**Magnetic Contactor (MC)**  
Turns on/off the main power of the servo driver. Surge absorber to be used together with this.

**Reactor (L)**  
Reduces harmonic current of the main power.

**Pin-5 and Pin-3 of CN POWER**

• Connect an external regenerative resistor (option) between P(pin-5) and B(pin-3) of connector, CN X1, when regenerative energy is large. (Refer to P.242 for regenerative resistor.)

- Motor to P.227
- Driver to P.223
- Option to P.236
- Recommended equipments
- Parts customer to prepare

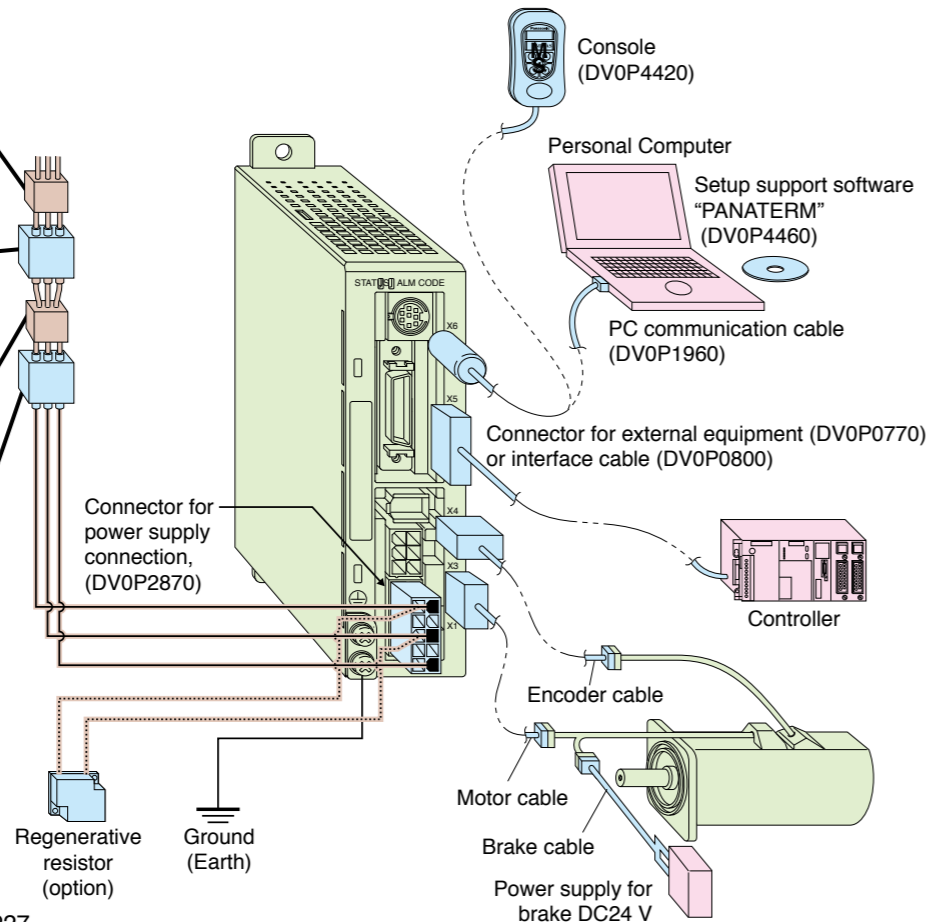

■ List of recommended peripheral equipments

Power supply	Motor		Power capacity (at rated output)	Circuit Breaker (Rated current)	Noise Filter	Magnetic Contactor Contact Composition	Wire diameter (L1, L2, L3, U, V and W)
	Series	Output					
Single phase, 100 V	MUMA	50 W	0.3 kVA	(5 A)	DV0P4160	10 A (3P+1a)	0.75 mm <sup>2</sup> to 0.85 mm <sup>2</sup> AWG18
		100 W	0.4 kVA	(10 A)			
		200 W	0.5 kVA	(5 A)			
Single phase, 200 V	MUMA	50 W	0.3 kVA	(5 A)		15 A (3P+1a)	
		100 W	0.4 kVA	(10 A)			
		200 W	0.5 kVA	(5 A)			
3-phase 200 V	MUMA	50 W	0.3 kVA	(5 A)	10 A (3P+1a)		
		100 W	0.4 kVA	(10 A)			
		200 W	0.5 kVA	(10 A)			

- \* Select the single and 3-phase common specifications corresponding to the power supplies.
- To conform to EC Directives, install a circuit breaker which conforms to IEC and UL Standards (Listed, marked) between noise filter and power supply.
- For details of the noise filters, refer to P.256.

<Remarks>

- Use a copper conductor cables with temperature rating of 60 °C or higher for main power connector and ground terminal wiring.
- Use a cable for ground with diameter of 2.0 mm<sup>2</sup> (AWG14) or larger.

■ Carrying page

Options	Part No.	Carrying page
Technical Reference	Japanese	DV0P3680
	English	DV0P3700
Console	DV0P4420	241
Setup Support Software, PANATERM	Japanese	DV0P4460
	English	DV0P4460
RS232 Communication Cable (for Connection with PC)	DV0P1960	241
Interface Cable	DV0P0800	241
Connector Kit for External Equipment	DV0P0770	240
Connector Kit for Motor and Encoder	DV0P3670	239
Connector Kit for Driver Power Supply	DV0P2870	239
Encoder Cable	MFECA0 * * 0EAM	238
Motor Cable	MFMCA0 * * 0AEB	238
Brake Cable	MFMCB0 * * 0GET	238
Cable Set (3 m) <sup>(Note 3)</sup>	DV0P37300	238
Cable Set (5 m) <sup>(Note 3)</sup>	DV0P39200	238
DIN Rail Mount Unit	DV0P3811	242
External Regenerative Resistor	100 V 50 Ω 10 W	DV0P2890
	200 V 100 Ω 10 W	DV0P2891
Reactor	100 V	DV0P227
		DV0P228
	200 V	DV0P220
Noise Filter	DV0P4160	256
Surge Absorber	Single phase 100 V, 200 V	DV0P4190
	3-phase 200 V	DV0P1450
Noise Filter for Signal Wire	DV0P1460	256

(Note 3) Cable set (3 m) contains,  
 1) Interface cable: DV0P0800  
 2) Encoder cable (3 m) : MFECA0030EAM  
 3) Motor cable (3 m) : MFMCA0030AEB  
 4) Connector kit for driver power supply connection : DV0P2870  
 Cable set (5 m) contains,  
 1) Interface cable: DV0P0800  
 2) Encoder cable (5 m) : MFECA0050EAM  
 3) Motor cable (5 m) : MFMCA0050AEB  
 4) Connector kit for driver power supply connection : DV0P2870

■ Table of Part Numbers and Options

Power supply	Output (W)	2500P/r, Incremental				Option					
		Motor <sup>Note) 1</sup>	Rating/Spec. (page)	Driver	Dimensions (Frame symbol)	Encoder Cable <sup>Note) 2</sup>	Motor Cable <sup>Note) 2</sup>	Brake Cable <sup>Note) 2</sup>	External Regenerative Resistor	Reactor	Noise Filter
Single phase 100 V	50	MUMA5AZP1 □	227	MKDET1105P	226 (K)	MFECA0 * * 0EAM	MFMCA0 * * 0AEB		DV0P2890	DV0P227	DV0P4160
	100	MUMA011P1 □	227	MKDET1110P	226 (K)						
	200	MUMA021P1 □	227	MLDET2110P	226 (L)						
Single phase 200 V	50	MUMA5AZP1 □	229	MKDET1505P	226 (K)						
	100	MUMA012P1 □	229	MKDET1505P	226 (K)						
	200	MUMA022P1 □	229	MLDET2210P	226 (L)						
3-phase 200 V	400	MUMA042P1 □	229	MLDET2510P	226 (L)						
	50	MUMA5AZP1 □	229	MKDET1505P	226 (K)						
	100	MUMA012P1 □	229	MKDET1505P	226 (K)						
	200	MUMA022P1 □	229	MKDET1310P	226 (K)						
	400	MUMA042P1 □	229	MLDET2510P	226 (L)						
				MLDET2310P							

Note) 1 Motor model number suffix: □  
 S : Key way with center tap, without brake  
 T : Key way with center tap, with brake  
 Note) 2 \* \* represents cable length. For details, refer to P.237.



Basic Specifications	Input power	Single phase, 100 V	Single phase, 100 V to 115 V $+10\%$ $-15\%$	50/60 Hz	
		Single phase, 200 V	Single phase, 200 V to 240 V $+10\%$ $-15\%$	50/60 Hz	
		3-phase, 200 V	3-phase, 200 V to 240 V $+10\%$ $-15\%$	50/60 Hz	
	Environment	Temperature	Operating : 0 to 55 °C, Storage : -20 °C to 65 °C (Max.temperature guarantee 80 °C for 72 hours <Nomal temperature>)		
		Humidity	Both operating and storage : 90 %RH or less (free from condensation)		
		Altitude	1000 m or lower		
		Vibration	5.88 m/s <sup>2</sup> or less, 10 to 60 Hz (No continuous use at resonance frequency)		
	Withstand voltage	Should be 1500 VAC (Sensed current: 20 mA) for 1 minute between Primary and Ground.			
	Control method	IGBT PWM Sinusoidal wave drive			
	Encoder feedback	2500 P/r (10000 resolution) incremental encoder			
	Control signal	Input	7 inputs (1) Servo-ON, (2) Alarm clear and other inputs vary depending on the control mode.		
		Output	4 outputs (1) Servo alarm, (2) Alarm, (3) Release signal of external brake and other outputs vary depending on the control mode.		
	Pulse signal	Input	2 inputs Supports both line driver I/F and open collector I/F.		
		Output	4 outputs Feed out the encoder pulse (A, B and Z-phase) in line driver. Z-phase pulse is also feed out in open collector.		
Communication function	RS232	1 : 1 communication to a host with RS232 interface is enabled.			
Display LED	(1) Status LED (STATUS), (2) Alarm code LED (ALM-CODE)				
Regeneration	No built-in regenerative resistor (external resistor only)				
Dynamic brake	Built-in				
Control mode	3 modes of (1) High-speed position control, (2) Internal velocity control and (3) High-functionality positioning control are selectable with parameter.				
Position control	Control input	(1) CW over-travel inhibition, (2) CCW over-travel inhibition, (3) Deviation counter clear, (4) Gain switching, (5) Electronic gear switching			
	Control output	(1) Positioning complete (In-position)			
	Pulse input	Max. command pulse frequency	Line driver : 500 kpps, Open collector : 200 kpps		
		Type of input pulse train	Differential input. Selectable with parameter, ((1) CW/CCW, (2) A and B-phase, (3) Command and Direction)		
		Electronic gear (Division/Multiplication of command pulse)	Setup of electronic gear ratio Setup range of $(1-10000) \times 2^{(0-17)} / (1-10000)$		
Smoothing filter	Primary delay filter or FIR type filter is selectable to the command input.				
Internal speed control	Control input	(1) CW over-travel inhibition, (2) CCW over-travel inhibition, (3) Selection 1 of internal command speed, (4) Selection 2 of internal command speed, (5) Speed zero clamp			
	Control output	(1) Speed arrival (at-speed)			
	Internal speed command	Internal 4-speed is selectable with control input.			
	Soft-start/down function	Individual setup of acceleration and deceleration are enabled, with 0 to 10 s/1000 r/min. Sigmoid acceleration/deceleration is also enabled.			
	Zero-speed clamp	0-clamp of internal speed command with speed zero clamp input is enabled.			
Auto-gain tuning	Real-time	Estimates the load inertia in real-time in actual operation and sets up the gain automatically corresponding to the machine stiffness. Useable at (1) High-response position control, (2) Internal speed control and (3) High-functionality position control.			
	Normal mode	Estimates the load inertia with an action command inside of the driver, and sets up the gain automatically corresponding to setup of the machine stiffness. Useable at (1) High-response position control, (2) Internal speed control and (3) High-functionality position control.			
Common	Masking of unnecessary input	Masking of the following input signal is enabled. (1) Over-travel inhibition, (2) Speed zero clamp, (3) Torque limit switching			
	Division of encoder feedback pulse	1 P/r to 2500 P/r (encoder pulses count is the max.).			
	Protective function	Hardware error	Over-voltage, under-voltage, over-speed over-load, over-heat, over-current and encoder error etc.		
		Software error	Excess position deviation, command pulse division error, EEPROM error etc.		
	Traceability of alarm data	Traceable up to past 14 alarms including the present one.			
	Damping control function	Manual setup with parameter			
Setup	Manual	Console			
	Setup support software	PANATERM (Supporting OS : Windows98, Windows ME, Windows2000, and WindowsXP)			

Standard Wiring Example of Main Circuit

3-Phase, 200 V

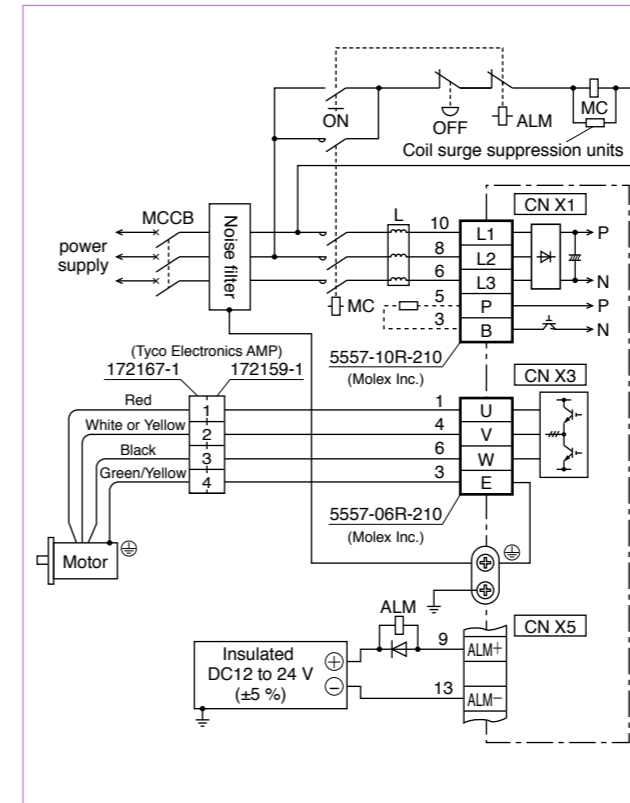

Single Phase, 100 V / 200 V

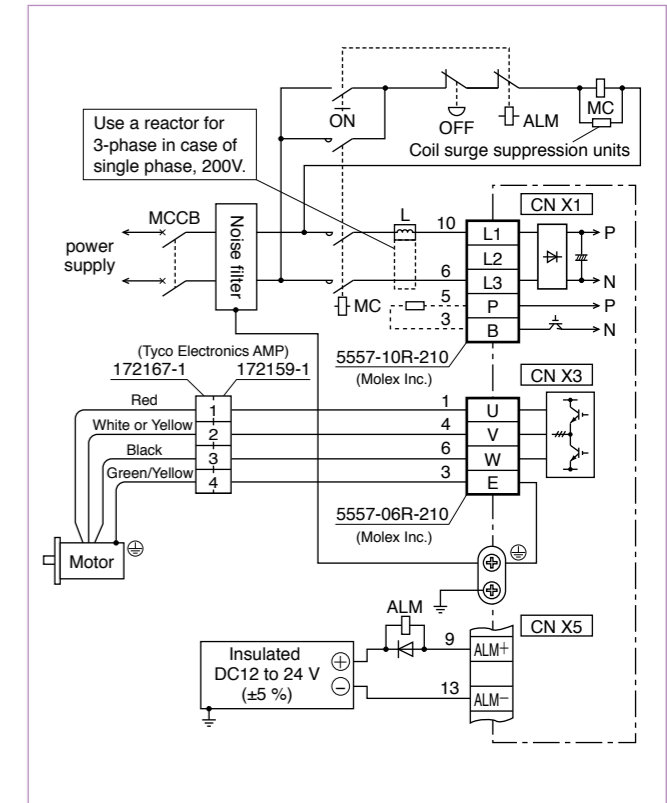

Encoder Wiring Diagram

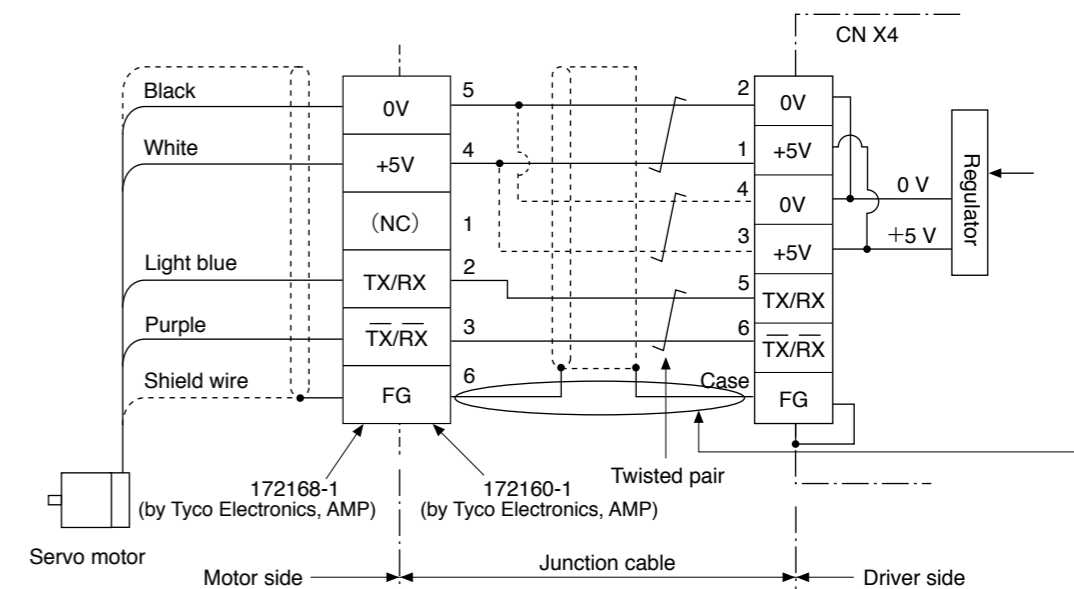

When you make your own junction cable for encoder (Refer to P.239, P.240 "Options" for connector.)

- 1) Refer the wiring diagram.
- 2) Use the twisted pair wire with shield, with core diameter of 0.18 mm<sup>2</sup> (AWG24) or larger, with higher bending resistance.
- 3) Use the twisted pair wire for the corresponding signal and power supply.
- 4) Shielding  
Connect the shield of the driver to the case of CN X4.  
Connect the shield of the motor to Pin-6.

CN X 5 Wiring Example at Position Control Mode

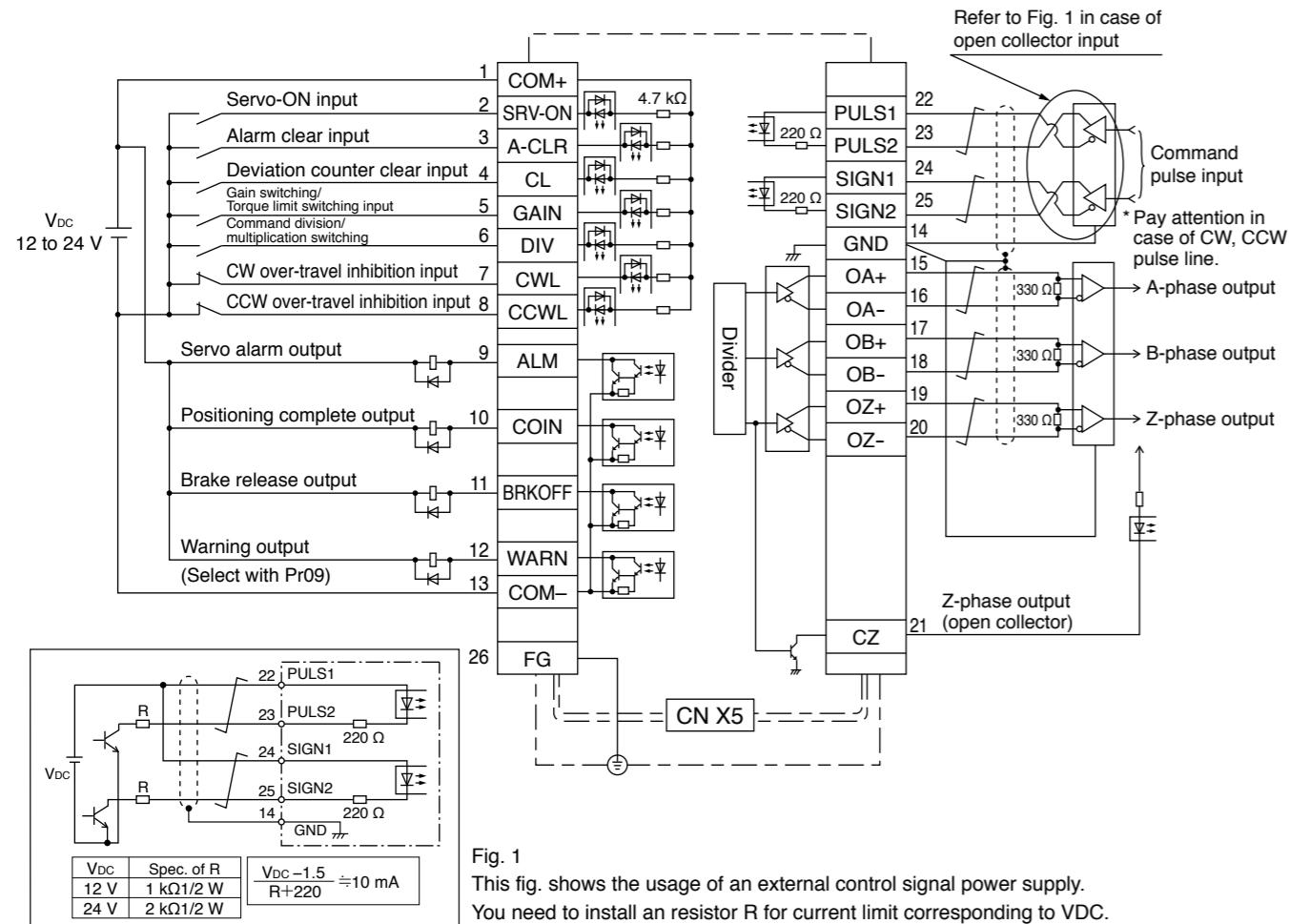

CN X 5 Wiring Example at Internal Velocity Control Mode

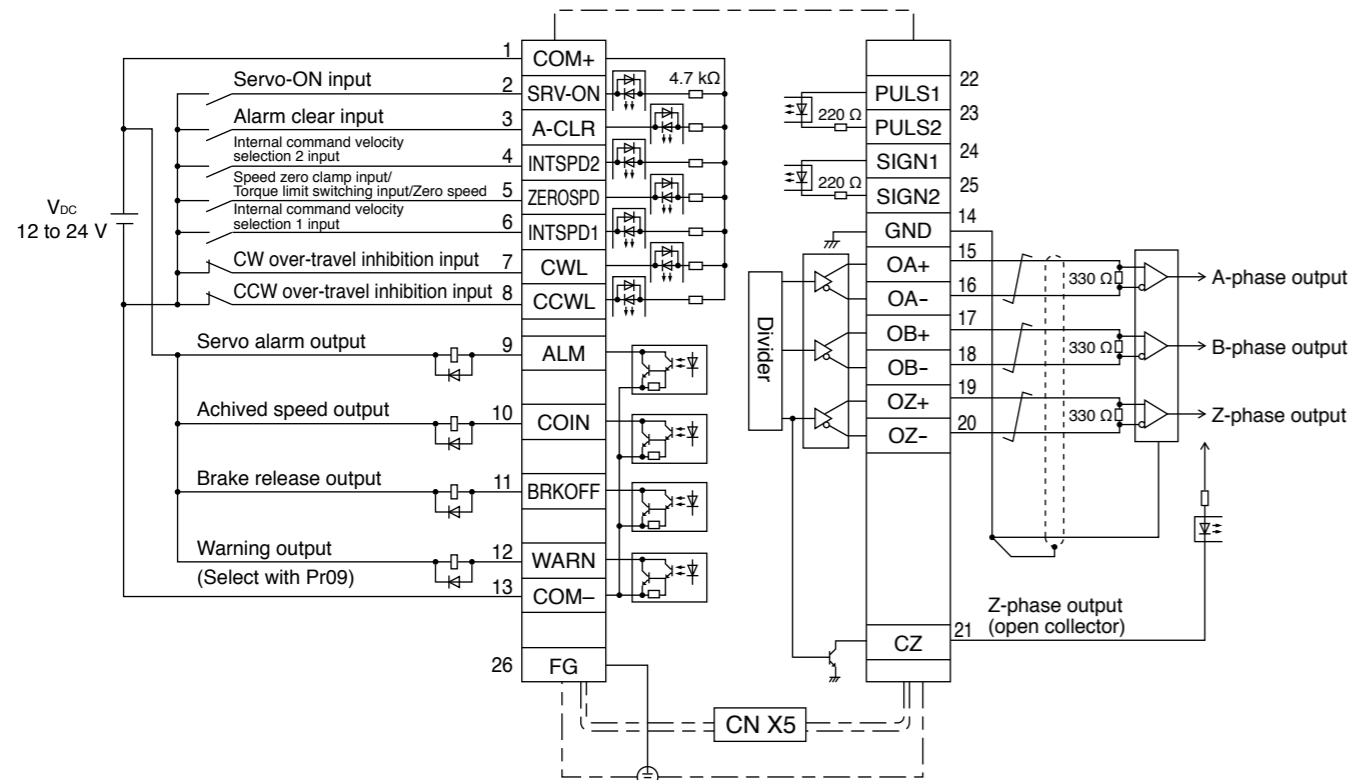

Frame K

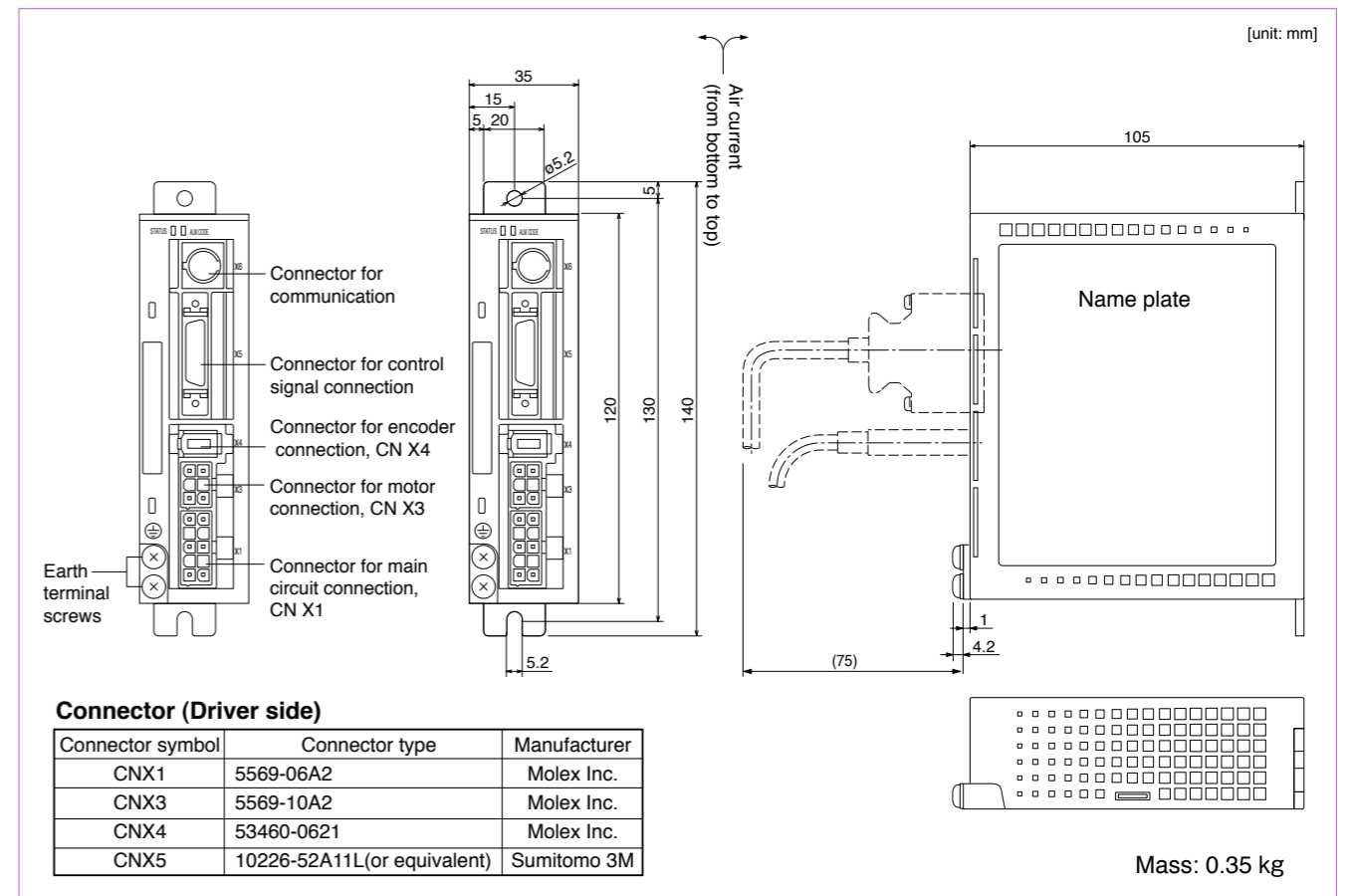

Frame L

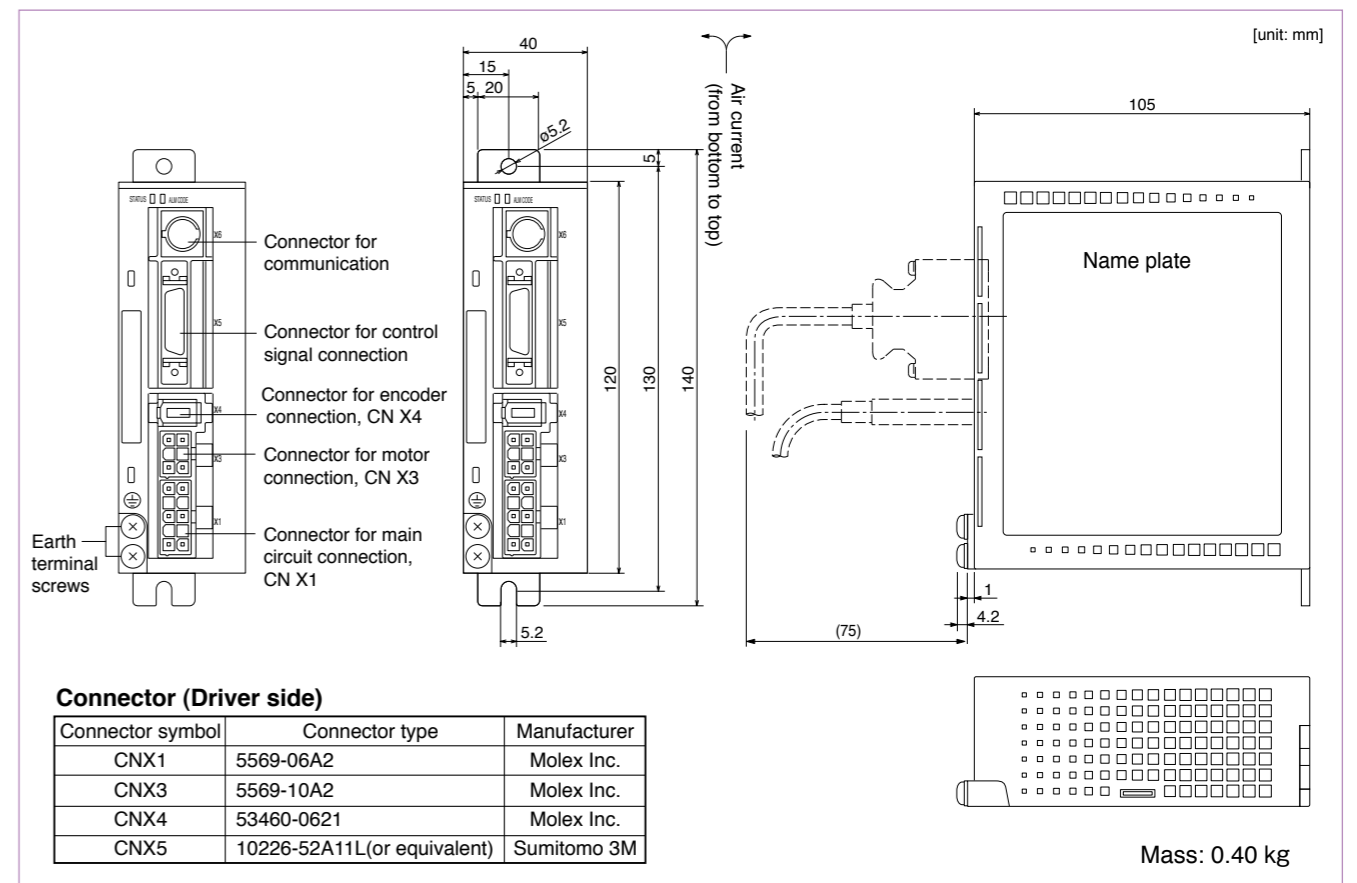

		AC100 V			
Motor model		MUMA	5AZP1□	011P1□	021P1□
Applicable driver	Model No.	MKDET1105P	MKDET1110P	MLDET2110P	
	Frame symbol	Frame K		Frame L	
Power supply capacity (kVA)		0.3	0.4	0.5	
Rated output (W)		50	100	200	
Rated torque (N·m)		0.16	0.32	0.64	
Momentary Max. peak torque (N·m)		0.48	0.95	1.91	
Rated current (Arms)		1.0	1.6	2.5	
Max. current (Ao-p)		4.3	6.9	11.7	
Regenerative brake frequency (times/min) Note)1	Without option	No limit Note)2		No limit Note)2	
	DV0P2890	No limit Note)2		No limit Note)2	
Rated rotational speed (r/min)		3000			
Max. rotational speed (r/min)		5000			
Moment of inertia of rotor ( $\times 10^{-4}$ kg·m <sup>2</sup> )	Without brake	0.021	0.032	0.10	
	With brake	0.026	0.036	0.13	
Recommended moment of inertia ratio of the load and the rotor Note)3		30 times or less			
Rotary encoder specifications		2500 P/r			
		Incremental			
Resolution per single turn		10000			
Protective enclosure rating		IP65 (except rotating portion of output shaft and lead wire end)			
Environment	Ambient temperature	0 °C to 40 °C (free from freezing), Storage : -20 °C to 65 °C (Max. temperature guarantee 80 °C for 72 hours <nomal humidity>)			
	Ambient humidity	85 %RH or lower (free from condensing)			
	Installation location	Indoors (no direct sunlight), free from corrosive gas, inflammable gas, oil mist and dust			
	Altitude	1000 m or lower			
	Vibration resistance	49 m/s <sup>2</sup> or less			
Mass (kg), ( ) represents holding brake type		0.4 (0.6)	0.5 (0.7)	0.96 (1.36)	

Brake specifications (This brake will be released when it is energized. Do not use this for braking the motor in motion.)		
Static friction torque (N·m)	0.29	1.27
Engaging time (ms)	25	50
Releasing time (ms) Note)4	20 (30)	15 (100)
Exciting current (DC) (A)	0.26	0.36
Releasing voltage	DC 1 V or more	
Exciting voltage	DC 24 V 10 %	

Permissible load			
During assembly	Radial load P-direction (N)	147	392
	Thrust load A-direction (N)	88	147
	Thrust load B-direction (N)	117	196
During operation	Radial load P-direction (N)	68	245
	Thrust load A-direction (N)	58	98
	Thrust load B-direction (N)	58	98

For motor dimensions, refer to P.231, and for the diver, refer to P.226.

Model Designation

e.g.) M U M A 5 A Z P 1 S

Symbol	Type
MUMA	Ultra low inertia (50 W to 200 W)

Motor rated output	
Symbol	Rated output
5A	50 W
01	100 W
02	200 W

Voltage specifications	
Symbol	Specifications
1	100 V
Z	100/200 V (50 W only)

Design order 1 : Standard

Motor structure

Symbol	Shaft	Holding brake		Oil seal	
	Key-way, center tap	without	with	without	with
S	●	●		●	
T	●		●	●	

Rotary encoder specifications

Symbol	Format	Pulse counts	Resolution	Wires
P	Incremental	2500 P/r	10000	5

Torque Characteristics [at AC100 V of power voltage (Dotted line represents the torque at 10 % less supply voltage.)]

MUMA5AZP1□

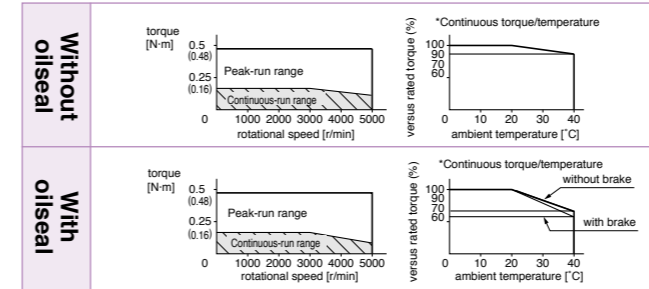

MUMA011P1□

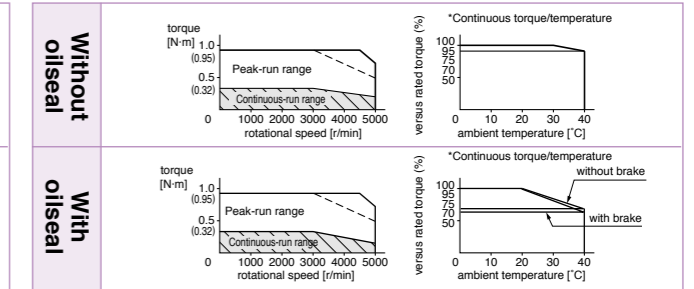

MUMA021P1□

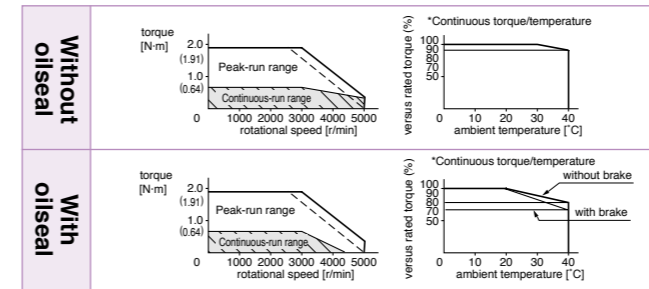

\*When you lower the torque limit setup (Pr5E and 5F), running range at high speed might be lowered as well.

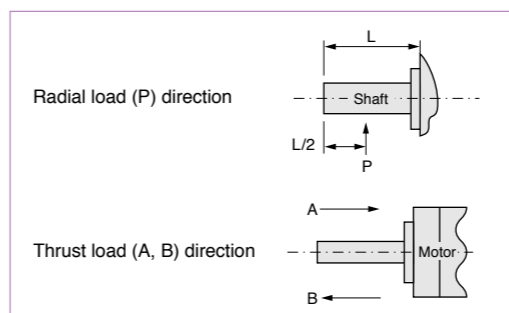
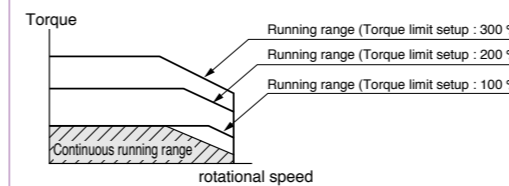

- Note) 1. Regenerative brake frequency represents the frequency of the motor's stops from the rated speed with deceleration without load.
- If the load is connected, frequency will be defined as  $1/(m+1)$ , where  $m = (\text{load moment of inertia}) / (\text{rotor moment of inertia})$ .
  - When the motor speed exceeds the rated speed, regenerative brake frequency is in inverse proportion to the square of (running speed/rated speed).
  - Power supply voltage is AC115 V (at 100 V of the main voltage). If the supply voltage fluctuates, frequency is in inverse proportion to the square of (Running supply voltage/115) relative to the value in the table.
  - When regeneration occurs continuously such cases as running speed frequently changes or vertical feeding, consult us or a dealer.
2. If the effective torque is within the rated torque, there is no limit in regenerative brake.
3. Consult us or a dealer if the load moment of inertia exceeds the specified value.
4. Specified releasing time is obtained with the use of surge absorber for brake (Z15D151 by SEMITEC Corporation or equivalent). ( ) represents the actually measured value using a diode (200 V, 1 A or equivalent)

		AC200 V			
Motor model	MUMA	5AZP1□	012P1□	022P1□	042P1□
Applicable driver	Model No.	MKDET1505P		MKDET1310P	MLDET2310P
	Frame symbol	Frame K		Frame K	Frame L
				Frame L	
Power supply capacity (kVA)		0.3	0.3	0.5	0.9
Rated output (W)		50	100	200	400
Rated torque (N · m)		0.16	0.32	0.64	1.3
Momentary Max. peak torque (N · m)		0.48	0.95	1.91	3.8
Rated current (Arms)		1.0	1.0	1.6	2.5
Max. current (Ao-p)		4.3	4.3	7.5	11.7
Regenerative brake frequency (times/min)	Without option	No limit		Note)2	
	Note)1	DV0P2891 x 1		No limit	
Rated rotational speed (r/min)		3000			
Max. rotational speed (r/min)		5000			
Moment of inertia of rotor (×10 <sup>-4</sup> kg·m <sup>2</sup> )	Without brake	0.021	0.032	0.10	0.17
	With brake	0.026	0.036	0.13	0.20
Recommended moment of inertia ratio of the load and the rotor	Note)3	30 times or less			
Rotary encoder specifications		2500 P/r			
	Resolution per single turn	Incremental 10000			
Protective enclosure rating		IP65 (except rotating portion of output shaft and lead wire end)			
Environment	Ambient temperature	0 °C to 40 °C (free from freezing), Storage : -20 °C to 65 °C (Max.temperature guarantee 80 °C for 72 hours <nomal humidity>)			
	Ambient humidity	85 %RH or lower (free from condensing)			
	Installation location	Indoors (no direct sunlight), free from corrosive gas, inflammable gas, oil mist and dust			
	Altitude	1000 m or lower			
Vibration resistance		49 m/s <sup>2</sup> or less			
Mass (kg), ( ) represents holding brake type		0.4 (0.6)	0.5 (0.7)	0.96 (1.36)	1.5 (1.9)

Brake specifications (This brake will be released when it is energized. Do not use this for braking the motor in motion.)		
Static friction torque (N · m)		0.29
Engaging time (ms)		25
Releasing time (ms)	Note)4	20 (30)
Exciting current (DC) (A)		0.26
Releasing voltage		DC 1 V or more
Exciting voltage		DC 24 V 10 %

Permissible load		
During assembly	Radial load P-direction (N)	147
	Thrust load A-direction (N)	88
	Thrust load B-direction (N)	117
During operation	Radial load P-direction (N)	68
	Thrust load A-direction (N)	58
	Thrust load B-direction (N)	58

For motor dimensions, refer to P.231, and for the driver, refer to P.226.

Note) Driver for 50 W and 100 W has a common power supply of single phase and 3-phase 200 V.

Driver for 200 W, the upper row is the power supply of 3-phase 200 V, and lower is the power supply of single-phase 200 V.

Driver for 400 W, the upper row is the power supply of 3-phase 200 V, and lower is the common power supply of single-phase and 3-phase 200 V.

Model Designation

e.g.) M U M A 5 A Z P 1 S

Symbol	Type
MUMA	Ultra low inertia (50 W to 400 W)

Symbol	Rated output
5A	50 W
01	100 W
02	200 W
04	400 W

Symbol	Specifications
2	200 V
Z	100/200 V (50 W only)

Design order 1 : Standard

Motor structure

Symbol	Shaft Key-way, center tap	Holding brake		Oil seal	
	without	with	without	with	
S	●	●		●	
T	●		●	●	

Rotary encoder specifications

Symbol	Format	Pulse counts	Resolution	Wires
P	Incremental	2500 P/r	10000	5

Torque Characteristics [at AC200 V of power voltage (Dotted line represents the torque at 10 % less supply voltage.)]

MUMA5AZP1□

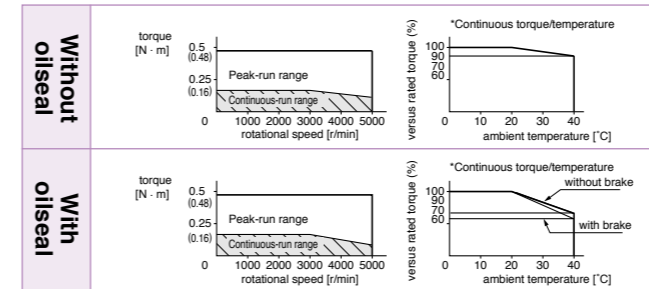

MUMA012P1□

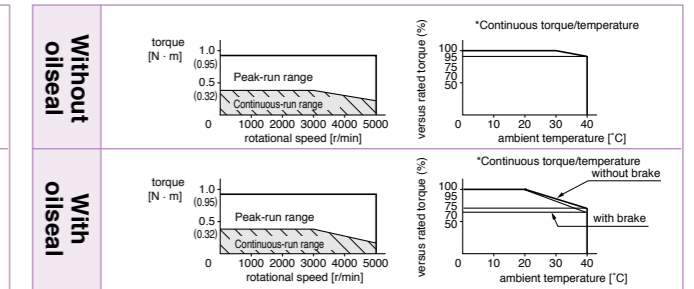

MUMA022P1□

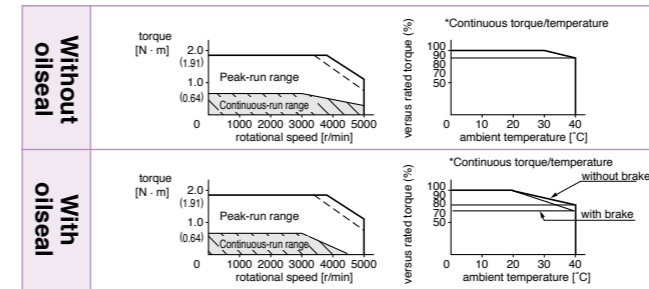

MUMA042P1□

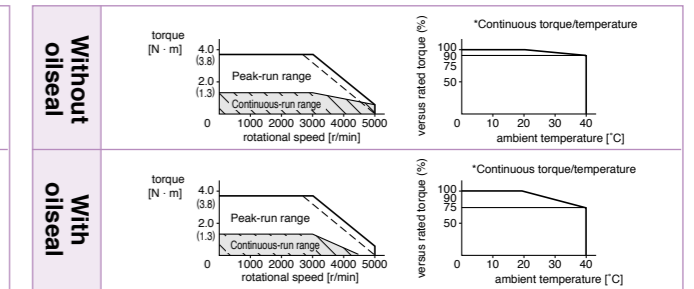

\*When you lower the torque limit setup (Pr5E and 5F), running range at high speed might be lowered as well.

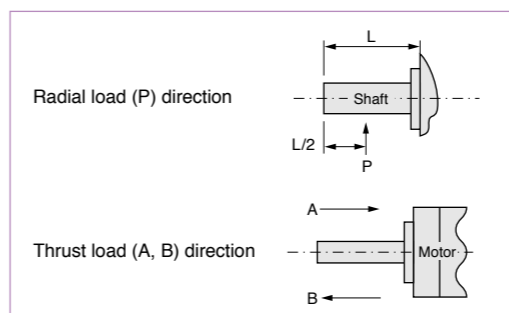
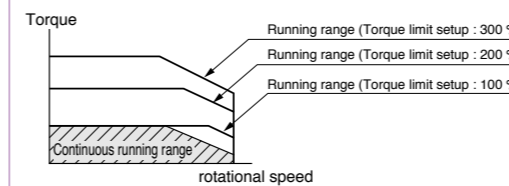

- Note) 1. Regenerative brake frequency represents the frequency of the motor's stops from the rated speed with deceleration without load.
- If the load is connected, frequency will be defined as 1/(m+1), where m = (load moment of inertia) / (rotor moment of inertia).
  - When the motor speed exceeds the rated speed, regenerative brake frequency is in inverse proportion to the square of (running speed/rated speed).
  - Power supply voltage is AC240 V (at 200 V of the main voltage). If the supply voltage fluctuates, frequency is in inverse proportion to the square of (Running supply voltage/240) relative to the value in the table.
  - When regeneration occurs continuously such cases as running speed frequently changes or vertical feeding, consult us or a dealer.
2. If the effective torque is within the rated torque, there is no limit in regenerative brake.
3. Consult us or a dealer if the load moment of inertia exceeds the specified value.
4. Specified releasing time is obtained with the use of surge absorber for brake (Z15D151 by SEMITEC Corporation or equivalent). ( ) represents the actually measured value using a diode (200 V, 1 A or equivalent)

[Unit: mm]

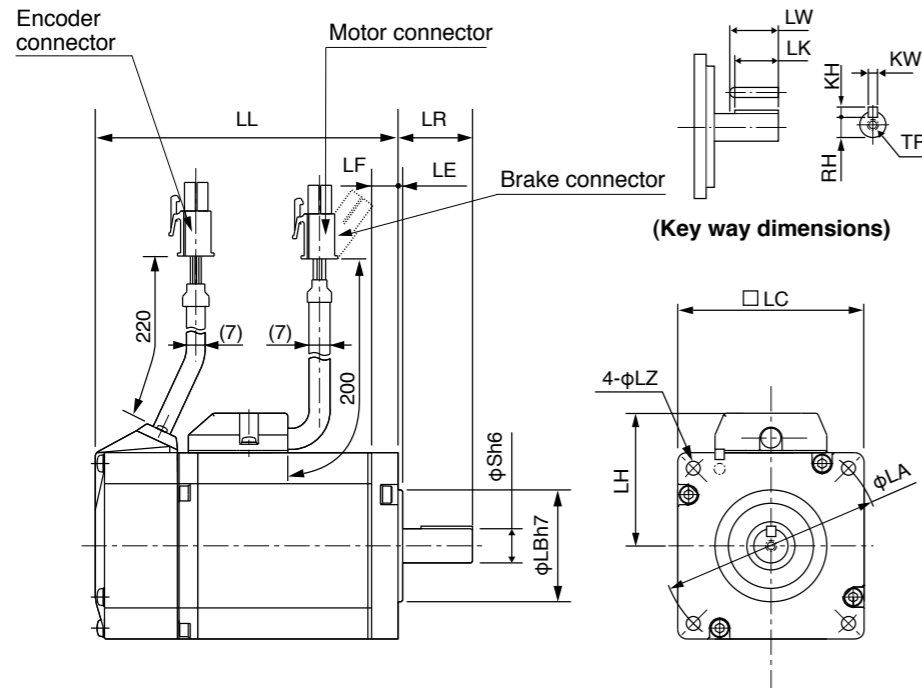

\* Dimensions are subject to change without notice. Contact us or a dealer for the latest information

[Unit: mm]

MUMA series (Ultra low inertia)

Motor output	50 W	100 W	200 W	400 W	
Motor model	<b>MUMA</b> 5A□P1□	01□P1□	02□P1□	04□P1□	
Rotary encoder specifications	2500 P/r Incremental	2500 P/r Incremental	2500 P/r Incremental	2500 P/r Incremental	
LL	Without brake	75.5	92.5	123.5	
	With brake	107	124	156.5	
LR	24	24	30	30	
S	8	8	11	14	
LA	48	48	70	70	
LB	22	22	50	50	
LC	42	42	60	60	
LE	2	2	3	3	
LF	7	7	7	7	
LH	34	34	43	43	
LZ	3.4	3.4	4.5	4.5	
Key way	LW	14	14	20	25
	LK	12.5	12.5	18	22.5
	KW	3h9	3h9	4h9	5h9
	KH	3	3	4	5
	RH	6.2	6.2	8.5	11
	TP	M3 × 6 (depth)	M3 × 6 (depth)	M4 × 8 (depth)	M5 × 10 (depth)
Mass (kg)	Without brake	0.40	0.50	0.96	1.5
	With brake	0.60	0.70	1.36	1.9
Connector/Plug specifications	refer to Options, P.239, P.240.				

<Cautions>

Reduce the moment of inertia ratio if high speed response operation is required.  
Read the Instruction Manual carefully and understand all precautions and remarks before using the products.

# MINAS E Series Motors with Gear Reducer

Motor Types with Gear Reducer

Reduction ratio	Motor output (W)			Type of reducer
	100	200	400	
1/5	●	●	●	For high precision
1/9	●	●	●	
1/25	●	●	●	

Efficiency of the gear reducer shows the following inclination in relation to output torque and rotational speed.

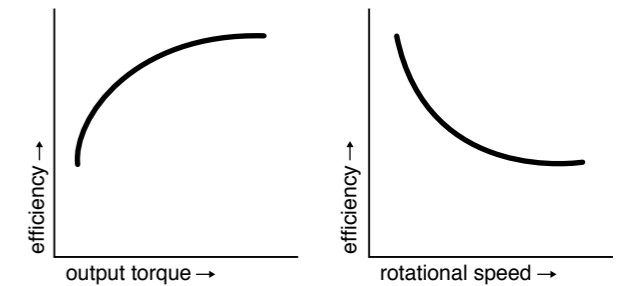

Model No. Designation

e.g.) M U M A 0 1 1 P 3 1 N

Symbol	Type
MUMA	Low inertia (100 to 400 W)

Symbol	Rated output
01	100 W
02	200 W
04	400 W

Symbol	Specifications
1	100 V
2	200 V

Symbol	Format	Pulse counts	Pulse counts	Wire
P	Incremental	2500 P/r	10000	5

Symbol	Reduction ratio	Motor output			Type of reducer
		100	200	400	
1N	1/5	●	●	●	For High precision
2N	1/9	●	●	●	
4N	1/25	●	●	●	

Symbol	Shaft Key-way		Holding brake	
	without	with	without	with
3	●	●	●	●
4	●	●	●	●

Specifications of Motor with Gear Reducer

Motor type	MUMA
Backlash	3 minutes or smaller (initial value) at output shaft of the reducer
Composition of gear	Planetary gear
Gear efficiency	65 % to 85 %
Rotational direction at output shaft (of reducer)	Same direction as the motor output shaft
Composition of gear	Planetary gear
Mounting method	Flange mounting
Permissible moment of inertia of the load (conversion to the motor shaft)	10 times or smaller than rotor moment of inertia of the motor
Protective structure	IP44 (at gear reducer)
Ambient temperature	0 to 40 °C
Ambient humidity	85 %RH (free from condensation) or less
Vibration resistance	49 m/s <sup>2</sup> or less (at motor frame)
Impact resistance	98 m/s <sup>2</sup> or less

Table of Motor Specifications

Model	MUMA with gear reducer												
	Output	Reduction ratio	Output	Rated speed	Max. speed	Rated torque	Peak max. torque	Moment of inertia (motor + reducer/converted to motor shaft)		Mass		Permissible radial load	Permissible thrust load
	(W)		(W)	(r/min)	(r/min)	(N·m)	(N·m)	w/o brake	w/ brake	w/o brake	w/ brake	(N)	(N)
MUMA01□P□1N	100	1/5	75	600	1000	1.18	3.72	0.072	0.076	1.05	1.25	490	245
MUMA01□P□2N		1/9	80	333	555	2.25	6.86	0.0663	0.0703	1.05	1.25	588	294
MUMA01□P□4N		1/25	80	120	200	6.27	19.0	0.0645	0.0685	2.20	2.40	1670	833
MUMA02□P□1N	200	1/5	170	600	1000	2.65	8.04	0.218	0.248	1.68	2.08	490	245
MUMA02□P□2N		1/9	132	333	555	3.72	11.3	0.368	0.398	2.66	3.06	1180	588
MUMA02□P□4N		1/25	140	120	200	11.1	33.3	0.388	0.418	2.66	3.06	1670	833
MUMA042P□1N	400	1/5	340	600	1000	5.39	16.2	0.533	0.563	3.2	3.6	980	490
MUMA042P□2N		1/9	332	333	555	9.51	28.5	0.438	0.468	3.2	3.6	1180	588
MUMA042P□4N		1/25	332	120	200	26.4	79.2	0.470	0.500	4.7	5.1	2060	1030

For dimensions, refer to P.235.

The Combination of the Driver and the Motor

Combination with driver		100 V			200 V		
Encoder	Motor output	Part No. of motor with reducer	Single phase, 100 V	Part No. of motor with reducer	3-phase, 200 V	Single phase, 200 V	
			Part No. of driver		Part No. of driver	Part No. of driver	
2500 P/r Incremental	100 W	MUMA011P□□N	MKDET1110P	MUMA012P□□N	MKDET1505P	MKDET1505P	
	200 W	MUMA021P□□N	MLDET2110P	MUMA022P□□N	MKDET1310P	MLDET2210P	
	400 W	-	-	MUMA042P□□N	MLDET2510P MLDET2310P	MLDET2510P	

For dimensions, refer to P.235.

Torque Characteristics

For High Precision (MUMA Series 100 W to 400 W)

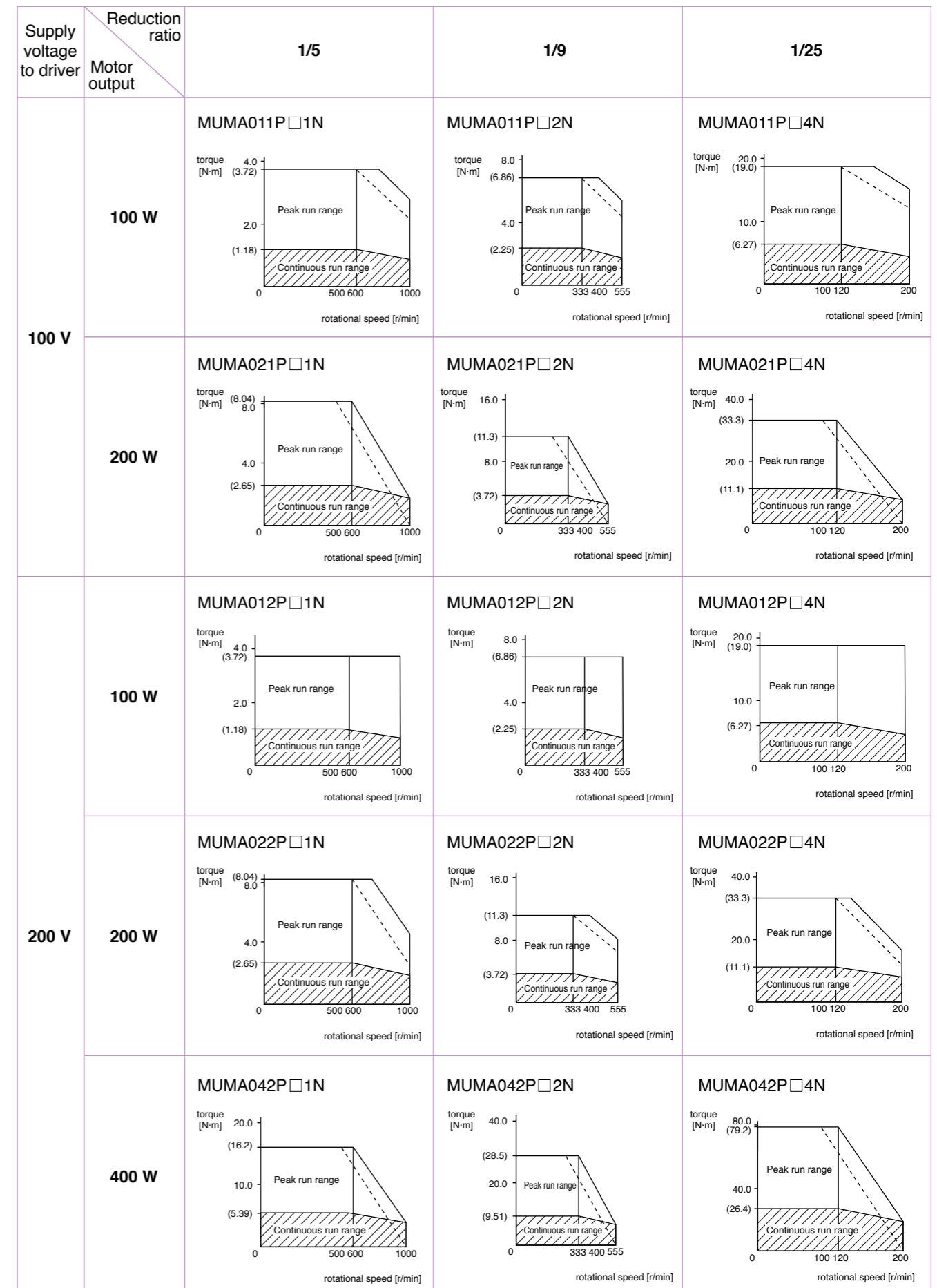

Dotted line represents the torque at 10 % less supply voltage.

MUMA series with Gear Reducer

[Unit: mm]

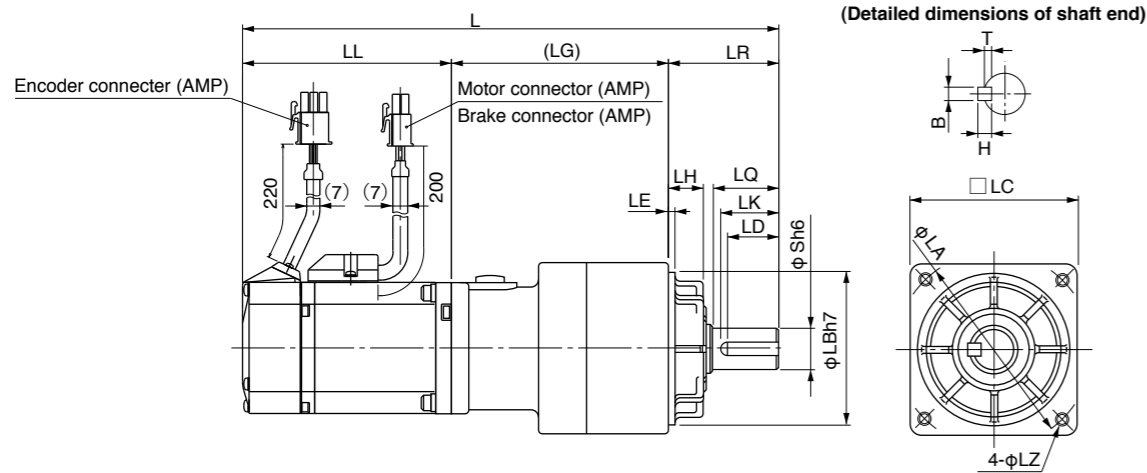

2500 P/r Encoder

[Unit: mm]

Model	Motor output	Reduction ratio	L	LL	LR	LQ	LC	LB	LA	S	LH	LZ	LK	(LG)	LE	Key way BxHxLD	T					
MUMA01□P□1N	100 W	1 / 5	192	92.5	32	20	52	50	60	12	10	M5 (Depth: 12)	18	67.5	3	4x4x16	2.5					
			223.5	124																		
MUMA01□P□2N		1 / 9	192	92.5	50	30	78	70	90	19	17	M6 (Depth: 20)	26	92	6x6x22	3.5						
			223.5	124																		
MUMA01□P□4N		1/25	234.5	92.5	266	124	200 W	1 / 5	200.5	96	32	20	52	50	60	12	10	M5 (Depth: 12)	18	72.5	4x4x16	2.5
MUMA02□P□1N		1 / 5	233.5	129	235.5	96	50	30	78	70	90	19	M6 (Depth: 20)	26	100	6x6x22	3.5					
MUMA02□P□2N	1 / 9	268.5	129	246	96	89.5																
MUMA02□P□4N	1/25	279	129	279	129	400 W	1 / 5	263	123.5	61	40	98	90	115	24	18	M8 (Depth: 20)	35	104	5	8x7x30	4
MUMA042P□1N	1 / 5	296	156.5	263	123.5	89.5																
MUMA042P□2N	1 / 9	296	156.5	288.5	123.5	61	40	98	90	115	24	18	M8 (Depth: 20)	35	104	5	8x7x30	4				
MUMA042P□4N	1/25	321.5	156.5																			

Upper column : without brake  
Lower column : with brake

Setup Support Software

Setup Support Software "PANATERM" for MINAS series AC Servo Motor & Driver

Part No. DV0P4460 (Japanese/English version)

The PANATERM assists users in setting parameters, monitoring control conditions, setup support, and analyzing mechanical operation data on the PC screen, when installed in a commercially available personal computer, and connected to the MINAS A4 series, E series through the RS232 serial interface.

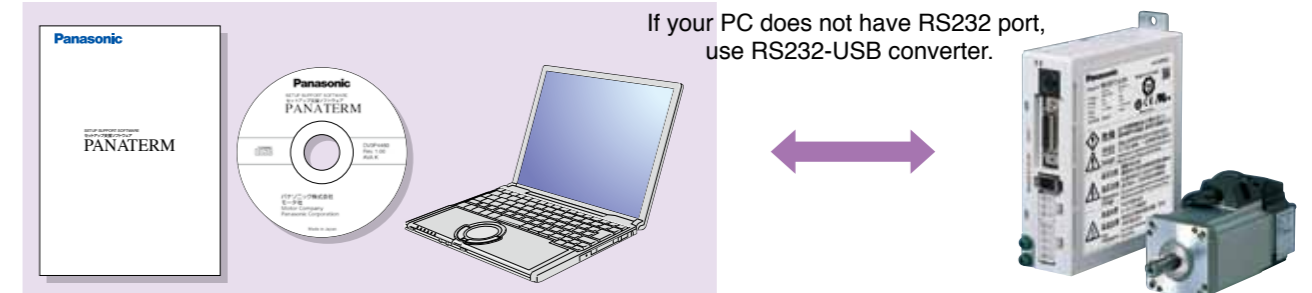

If your PC does not have RS232 port, use RS232-USB converter.

Basic Function

Parameter setup

- After a parameter is defined on the screen, it will be sent to the driver immediately.
- Once you register parameters you frequently use, they can be easily set up on the screen.

Monitoring Control Conditions

Monitor

- Control conditions: Control mode, velocity, torque, error and warning
- Driver input signal
- Load conditions: Total count of command/feedback pulses, Load ratio, Regenerative resistor load ratio

Alarm

- Displays the numbers and contents of the current alarm and up to 14 error events in the past.
- Clears the numbers and contents of the current alarm and up to 14 error events in the past.

Setup

Auto tuning

- Gain adjustment and inertia ratio measurement

Graphic waveform display

- The graphic display shows command velocity, actual velocity, torque, and error waveforms.

Absolute encoder setup

- Clears absolute encoder at the origin.
- Displays single revolution/multi-revolution data.
- Displays absolute encoder status.

Analysis of Mechanical Operation Data

Frequency analysis

- Measures frequency characteristics of the machine, and displays Bode diagram.

Can not use with A5 family.

Hardware configuration

- [Personal computer]** • CPU : Pentium 100MHz or more • Memory : 16 MB or more (32 MB recommended)
- Hard disk capacity (vacancy of 25 MB or more recommended) • OS : Windows® 98, Windows® Me, Windows® 2000, Windows® XP (US version)
- Communication speed of serial communication port : 2400 bps or more (The software may not operate normally using USB-to-Serial adapter.)
- [Display]** • Resolution : 640\*480 (VGA) or more (desirably 1024\*768) • Number of colors : 256 colors or more
- [CD-ROM drive]** • CD-ROM drive operable on the above-mentioned personal computer

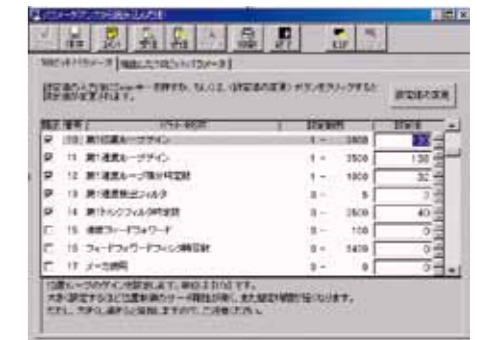

Parameter

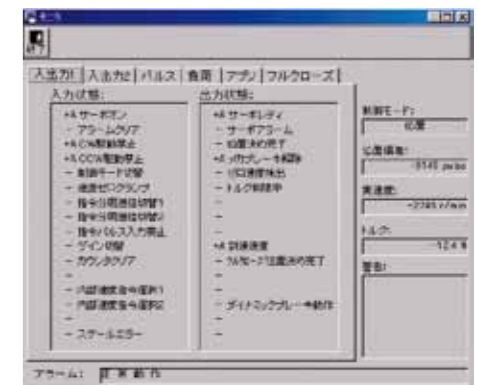

Monitor

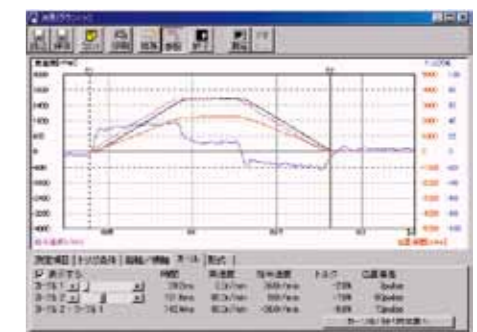

Graphic waveform display

Encoder Cable

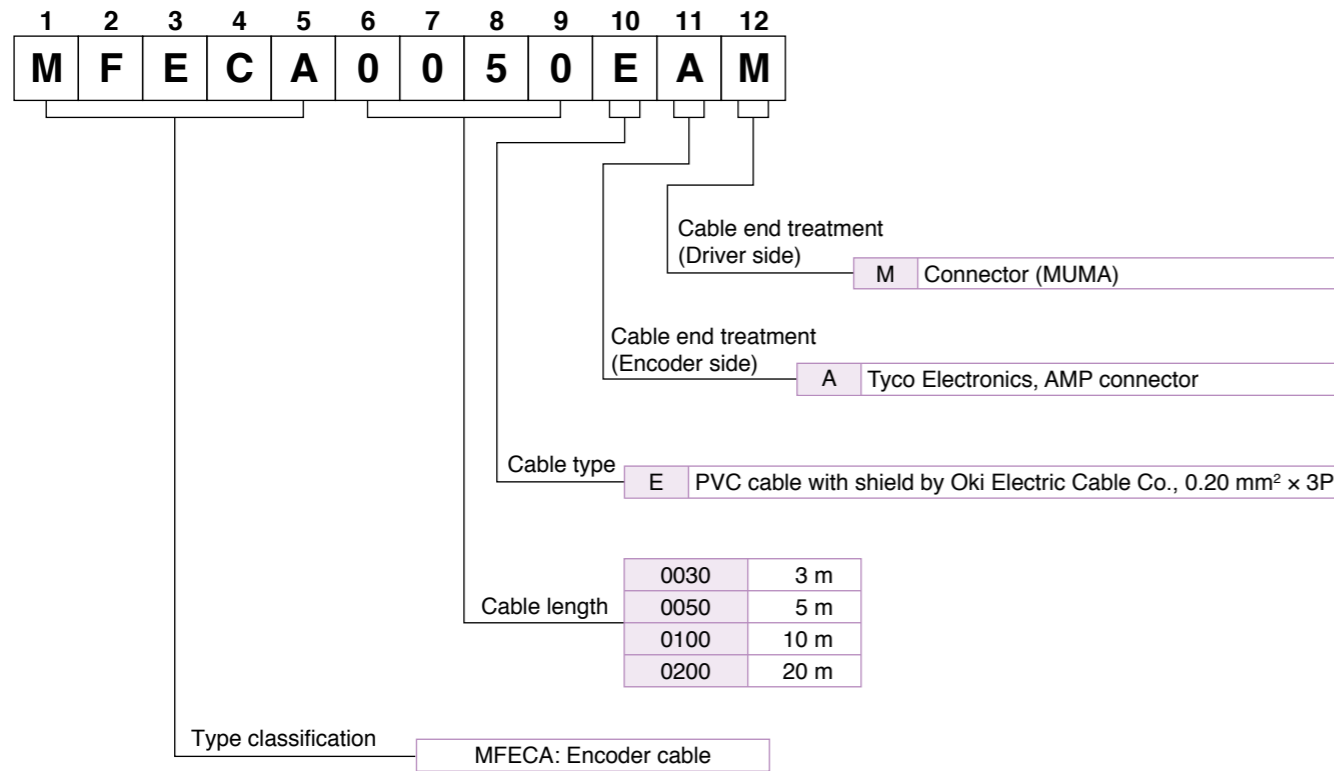

Motor Cable, Brake Cable

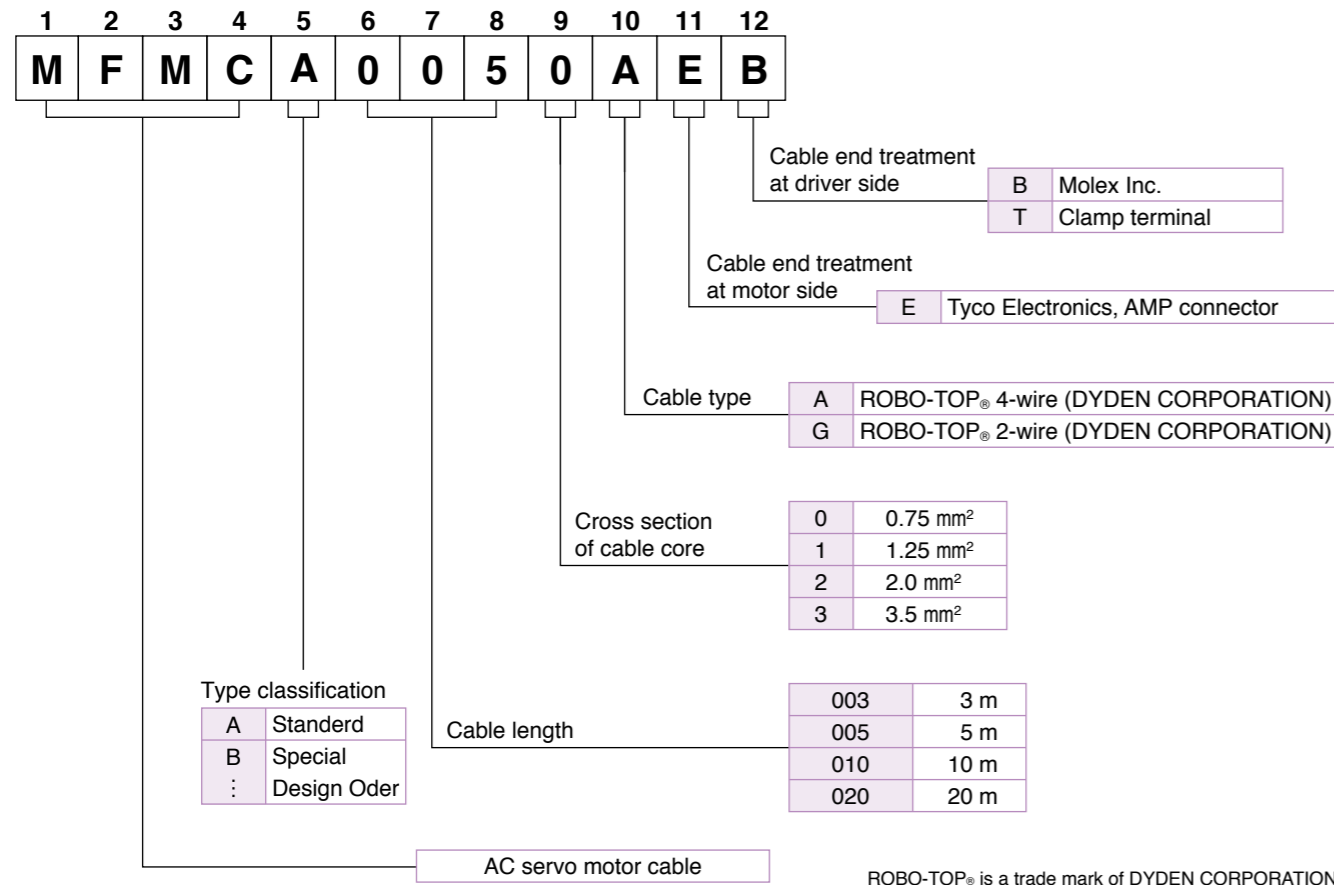

Cable

Cable Set (3 m)

- Part No. **DV0P37300**
- 1) Interface cable : DV0P0800
  - 2) Encoder cable (3 m) : MFECA0030EAM
  - 3) Motor cable (3 m) : MFMCA0030AEB
  - 4) Connector kit for driver power supply connection : DV0P2870

Cable Set (5 m)

- Part No. **DV0P39200**
- 1) Interface cable : DV0P0800
  - 2) Encoder cable (5 m) : MFECA0050EAM
  - 3) Motor cable (5 m) : MFMCA0050AEB
  - 4) Connector kit for driver power supply connection : DV0P2870

Encoder Cable

Part No. **MFECA0 \* \* 0EAM**

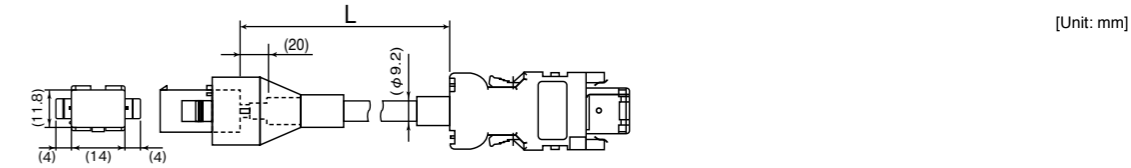

Title	Part No.	Manufacturer	L (m)	Part No.
Connector (Driver side)	3E206-0100KV	Sumitomo 3M	3	MFECA0030EAM
Shell kit	3E306-3200-008	or equivalent	5	MFECA0050EAM
Connector	172160-1	Tyco Electronics	10	MFECA0100EAM
Connector Pin	170365-1		20	MFECA0200EAM
Cable	0.20 mm <sup>2</sup> × 3P	Oki Electric Cable Co., Ltd.		

Motor Cable (ROBO-TOP® 105 °C 600 V . DP)

ROBO-TOP® is a trade mark of DYDEN CORPORATION

Part No. **MFMCA0 \* \* 0AEB**

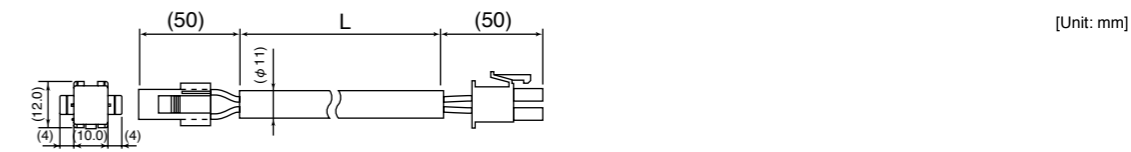

Title	Part No.	Manufacturer	L (m)	Part No.
Connector	172159-1	Tyco Electronics	3	MFMCA0030AEB
Connector Pin	170362-1, 170366-1		5	MFMCA0050AEB
Connector	5557-06R-210	Molex Inc	10	MFMCA0100AEB
Connector Pin	5556T		20	MFMCA0200AEB
Cable	ROBO-TOP 600 V 0.75 mm <sup>2</sup>	Daiden Co.,Ltd.		

Brake Cable (ROBO-TOP® 105 °C 600V . DP)

ROBO-TOP® is a trade mark of DYDEN CORPORATION

Part No. **MFMCB0 \* \* 0GET**

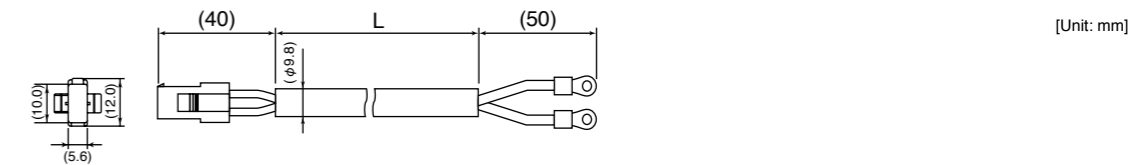

Title	Part No.	Manufacturer	L (m)	Part No.
Connector	172157-1	Tyco Electronics	3	MFMCB0030GET
Connector Pin	170362-1, 170366-1		5	MFMCB0050GET
Nylon insulated round terminal	N1.25-M4	J.S.T Mfg. Co., Ltd.	10	MFMCB0100GET
Cable	ROBO-TOP 600 V 0.75 mm <sup>2</sup>	Daiden Co.,Ltd.	20	MFMCB0200GET



Connector Kit for Power Supply Connection

Part No.	DV0P2870
----------	----------

● Parts composition

Title	Part No.	Number	Manufacturer	Note
Connector (10 pins)	5557-10R-210	1	Molex Inc.	For connector, CN X1 (10 pins)
Connector pin	5556PBTLL	6		

● Pin configuration of connector CN X1

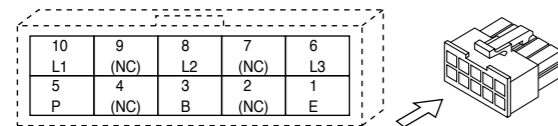

● Recommended manual crimping tool (to be prepared by customer)

Part No.	Cable material
57026-5000	UL1007
57027-5000	UL1015

<Cautions>

1. The above pin disposition is shown when viewed from the terminal inserting direction. Make a correct wiring by checking the stamped pin numbers on the connector itself.
2. Refer to P.224 for wiring and connection.
3. Do not connect anything to pins marked "NC".

Connector Kit for Motor/Encoder Connection

Part No.	DV0P3670 (Incremental 2500 pulse, 5-wire)
----------	---

This option is required when you make your own encoder cable and motor cable. (Brake cable is required for brake.)

● Parts composition

Title	Part No.	Number	Manufacturer	Note
Connector (Driver side)	3E206-0100 KV	1	Sumitomo 3M or equivalent	For connector, CN X4 (6 pins)
Shell kit	3E306-3200-008	1		
Connector (6 pins)	172160-1	1	Tyco Electronics	For junction to encoder cable (6 pins)
Connector pin	170365-1	6		
Connector (4 pins)	172159-1	1	Tyco Electronics	For junction to motor power cable (4 pins)
Connector pin	170366-1	4		
Connector (6 pins)	5557-06R-210	1	Molex Inc.	For connector, CN X3 (6 pins)
Connector pin	5556PBTLL	4		

<Remarks>

We may use parts equivalent to the above for shell and connector cover.

● Pin configuration of connector CN X4 plug

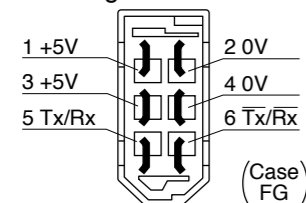

● Recommended manual crimping tool (to be prepared by customer)

Title	Part No.	Manufacturer	Cable material
For encoder cable junction	755330-1	Tyco Electronics	—
For motor power cable junction	755331-1		
For Connector CN X3	57026-5000	Molex Inc.	UL1007
	57027-5000		UL1015

<Remarks>

1. The above pin configuration is shown when viewed from the pin-soldering direction. Make a correct wiring by checking the stamped pin numbers on the connector itself.
2. Connect the shield of the wire to the case (FG) without fail.
3. For wiring and connection, refer to P.224.

● Pin configuration of encoder cable junction

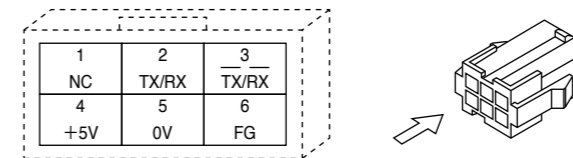

● Pin configuration of motor power cable junction

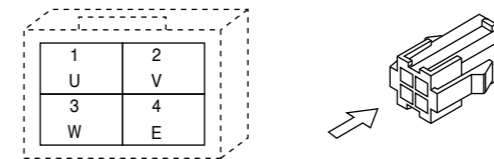

● Pin configuration of mating connector to CN X3 connector

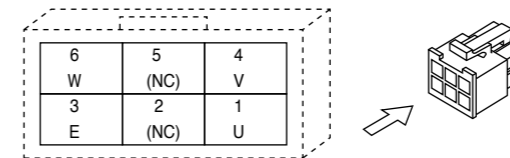

<Cautions>

1. The above pin configuration is shown when viewed from the terminal inserting direction. Make a correct wiring by checking the stamped pin numbers on the connector itself.
2. Refer to P.224 for wiring and connection.

Connector Kit for External Peripheral Equipment

Part No.	DV0P0770
----------	----------

● Parts composition

Title	Part No.	Number	Manufacturer	Note
Connector	10126-3000PE	1	Sumitomo 3M or equivalent	For connector, CN X5 (26 pins)
Connector cover	10326-52A0-008	1		

● Pin configuration of connector CN X5 (26 pins) (viewed from the soldering side)

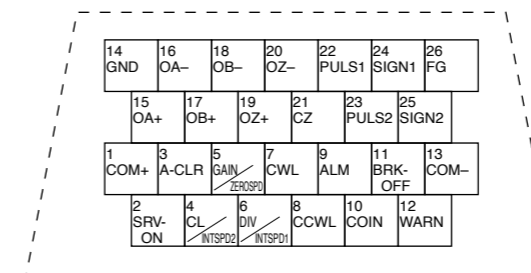

<Cautions>

1. Make a correct wiring by checking the stamped pin numbers on the connector itself.
2. Refer to P.225 for symbols and functions of the above signals.

Interface Cable

Part No. DV0P0800 Cable of 2 m is connected.

● Dimensions

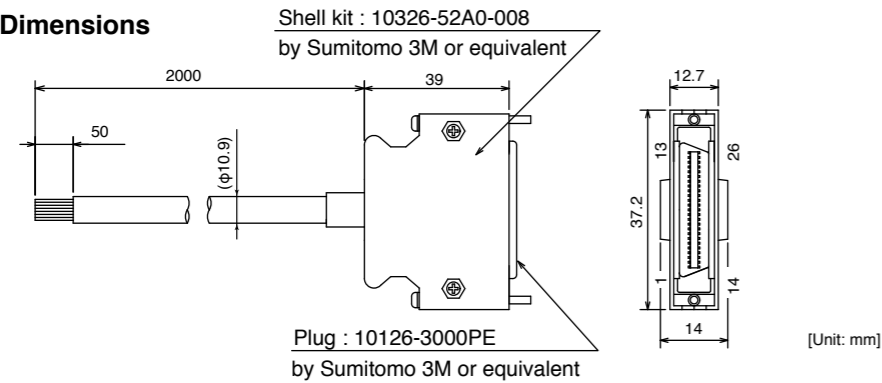

● Wiring table

Pin No.	Title of signal	Color or cable	Pin No.	Title of signal	Color or cable	Pin No.	Title of signal	Color or cable
1	COM+	Orange (Red 1)	10	COIN	Pink (Black 1)	19	OZ+	Pink (Red 2)
2	SRV-ON	Orange (Black 1)	11	BRK-OFF	Orange (Red 2)	20	OZ-	Pink (Black 2)
3	A-CLR	Gray (Red 1)	12	WARN	Orange (Black 2)	21	CZ	Orange (Red 3)
4	CL/INTSPD2	Gray (Black 1)	13	COM-	Gray (Red 2)	22	PULS1	Gray (Red 3)
5	GAIN/ZEROSPD	White (Red 1)	14	GND	Gray (Black 2)	23	PULS2	Gray (Black 3)
6	DIV/INTSPD1	White (Black 1)	15	OA+	White (Red 2)	24	SIGN1	White (Red 3)
7	CWL	Yellow (Red 1)	16	OA-	White (Black 2)	25	SIGN2	White (Black 3)
8	CCWL	Yellow (Black 1)	17	OB+	Yellow (Red 2)	26	FG	Orange (Black 3)
9	ALM	Pink (Red 1)	18	OB-	Yellow (Black 2)			

<Notes>

e. g. of Pin No. designation : Pin No. 1 ..... Wire color is orange, and one red dot.  
Pin No. 12 ... Wire color is orange, and two black dot.

<Remarks>

The shield of this cable is not connected to a connector pin. To connect the shield to FG or GND at the driver side, use a connector kit for external device connection.

Communication Cable (For Connection with PC)

Part No. DV0P1960

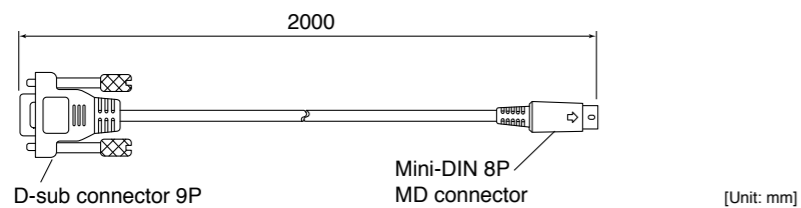

Console

Part No. DV0P4420

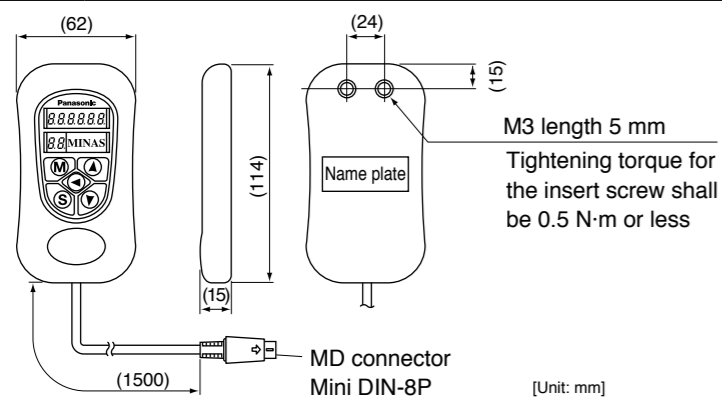

DIN Rail Mounting Unit

Part No. DV0P3811

● Dimensions

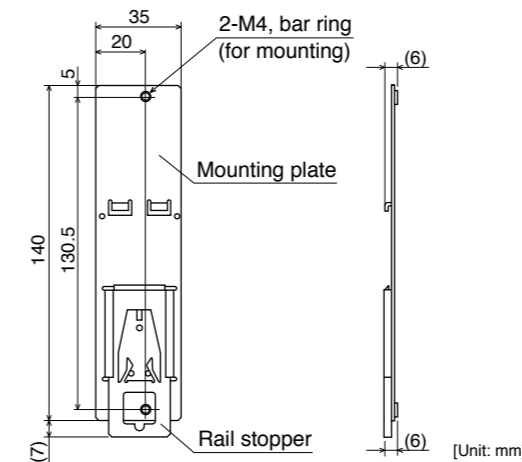

<Notes>

2 mounting screws (M4 X L8, Pan head) are attached.  
Rail stopper can be extended to max. 10 mm.

<Cautions>

Please read carefully operation manual before using this product.  
In addition, please do not apply excessive stress to the product.

• Driver mounted to DIN rail

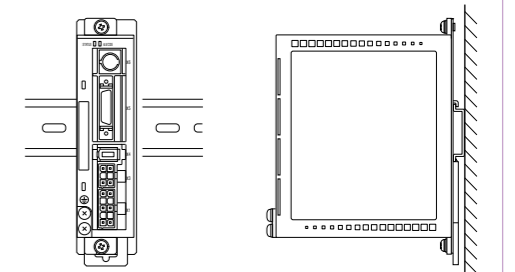

• How to Install

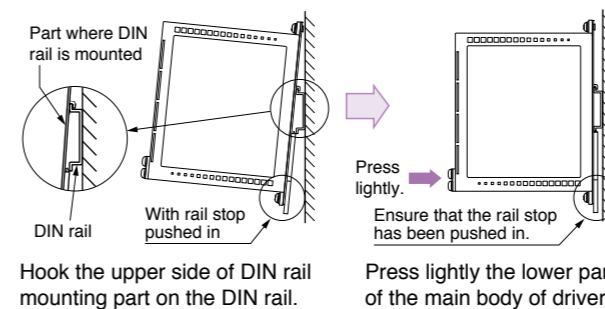

• Removing from DIN Rail

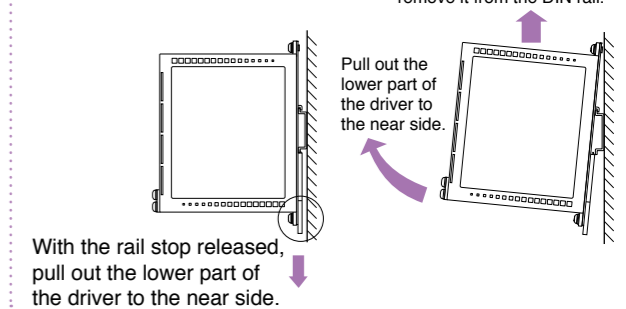

External Regenerative Resistor

Part No.	Manufacturer's Part No.	Specifications			Note (Input Power of drive)
		Resistance Ω	Rated power W	Activation temperature of built-in fuse °C	
DV0P2890	45M03	50	10	137 <sup>+0.3</sup> <sub>-0.3</sub>	Single phase, 100 V
DV0P2891	45M03	100	10	137 <sup>+0.3</sup> <sub>-0.3</sub>	Single/3-phase, 200 V

Manufactured by Iwaki Musen Kenkyusho Co., Ltd.

● Dimensions

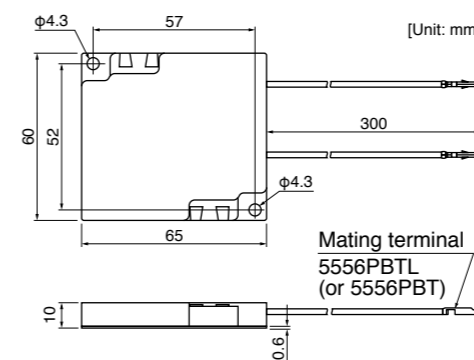

<Caution>

Regenerative resistor gets very hot.

Take preventive measures for fire and burns.  
Avoid the installation near inflammable objects, and easily accessible place by hand.

<Remarks>

Thermal fuse is installed for safety. The thermal fuse may blow due to heat dissipating condition, working temperature, supply voltage or load fluctuation.

Make it sure that the surface temperature of the resistor may not exceed 100 °C at the worst running conditions with the machine, which brings large regeneration (such case as high supply voltage, load inertia is large or deceleration time is short)

Reactor

Frame symbol of driver	Power supply specifications	Rated output	Part No.	Fig.
MKDE	Single phase, 100 V	50 to 100 W	DV0P227	1
	Single phase, 200 V	50 to 100 W	DV0P220	2
	3-phase, 200 V	50 to 200 W		
MLDE	Single phase, 100 V	200 W	DV0P228	1
	Single phase, 200 V	200 to 400 W	DV0P220	2
	3-phase, 200 V	400 W		

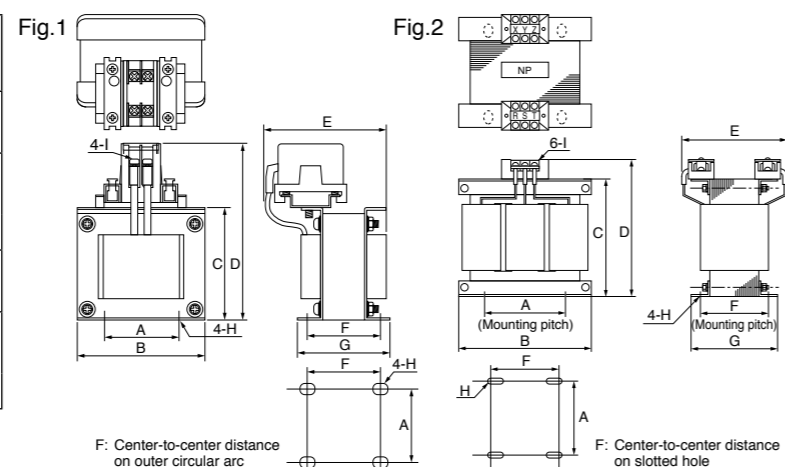

F: Center-to-center distance on outer circular arc (Fig. 1)  
F: Center-to-center distance on slotted hole (Fig. 2)

[Unit: mm]

	Part No.	A	B	C	D	E (Max)	F	G	H	I	Inductance (mH)	Rated current (A)
Fig.1	DV0P227	55±0.7	80±1	66.5±1	110 Max	90	41±2	55±2	4-5φ×10	M4	4.02	5
	DV0P228	55±0.7	80±1	66.5±1	110 Max	95	46±2	60±2	4-5φ×10	M4	2	8
Fig.2	DV0P220	65±1	125±1	(93)	136 Max	155	70+3/-0	85±2	4-7φ×12	M4	6.81	3

**Harmonic restraint on general-purpose inverter and servo driver**

On September, 1994, Guidelines for harmonic restraint on heavy consumers who receive power through high voltage system or extra high voltage system and Guidelines for harmonic restraint on household electrical appliances and general-purpose articles established by the Agency for Natural Resources and Energy of the Ministry of Economy, Trade and Industry (the ex-Ministry of International Trade and Industry). According to those guidelines, the Japan Electrical Manufacturers Association (JEMA) have prepared technical documents (procedure to execute harmonic restraint: JEM-TR 198, JEM-TR 199 and JEM-TR 201) and have been requesting the users to understand the restraint and to cooperate with us. On January, 2004, it has been decided to exclude the general-purpose inverter and servo driver from the Guidelines for harmonic restraint on household electrical appliances and general-purpose articles. After that, the Guidelines for harmonic restraint on household electrical appliances and general-purpose articles was abolished on September 6, 2004.

We inform you that the procedure to execute the harmonic restraint on general-purpose inverter and servo driver will be modified as follows.

1. All types of the general-purpose inverters and servo drivers used by specific users are under the control of the Guidelines for harmonic restraint on heavy consumers who receive power through high voltage system or extra high voltage system. The users who are required to apply the guidelines must calculate the equivalent capacity and harmonic current according to the guidelines and must take appropriate countermeasures if the harmonic current exceeds a limit value specified in a contract demand. (Refer to JEM-TR 210 and JEM-TR 225.)
2. The Guidelines for harmonic restraint on household electrical appliances and general-purpose articles was abolished on September 6, 2004. However, based on conventional guidelines, JEMA applies the technical documents JEM-TR 226 and JEM-TR 227 to any users who do not fit into the Guidelines for harmonic restraint on heavy consumers who receive power through high voltage system or extra high voltage system from a perspective on enlightenment on general harmonic restraint. The purpose of these guidelines is the execution of harmonic restraint at every device by a user as usual to the utmost extent.

<Remarks>

When using a reactor, be sure to install one reactor to one servo driver.

■ Recommended components

Surge Absorber for Motor Brake

Motor	Surge absorber for motor brake	
	Part No. (Manufacturer's)	Manufacturer
MUMA 50 W to 400 W	Z15D151	SEMITEC Corporation

List of Peripheral Components

List of Peripheral Components

Manufacturer	Tel No. / Home Page	Peripheral components
Panasonic Corporation Eco Solutions Company	<a href="http://panasonic.net/es/">http://panasonic.net/es/</a>	Circuit breaker
Panasonic Corporation Automotive & Industrial Systems Company	<a href="http://panasonic.net/id/">http://panasonic.net/id/</a>	Surge absorber Swich, Relay
Iwaki Musen Kenkyusho Co., Ltd.	+81-44-833-4311 <a href="http://www.iwakimusen.co.jp/">http://www.iwakimusen.co.jp/</a>	Regenerative resistor
SEMITEC Corporation	+81-3-3621-2703 <a href="http://www.semitec.co.jp/english2/">http://www.semitec.co.jp/english2/</a>	Surge absorber for motor brake
TDK Corporation	+81-3-5201-7229 <a href="http://www.global.tdk.com/">http://www.global.tdk.com/</a>	Noise filter for signal lines
Okaya Electric Industries Co. Ltd.	+81-3-4544-7040 <a href="http://www.okayaelec.co.jp/english/index.html">http://www.okayaelec.co.jp/english/index.html</a>	Surge absorber Noise filter
Sumitomo 3M	+81-3-5716-7290 <a href="http://solutions.3m.com/wps/portal/3M/ja_JP/WW2/Country/">http://solutions.3m.com/wps/portal/3M/ja_JP/WW2/Country/</a>	Connector
Tyco Electronics	+81-44-844-8052 <a href="http://www.te.com/ja/home.html">http://www.te.com/ja/home.html</a>	
Japan Molex Inc.	+81-462-65-2313 <a href="http://www.molex.co.jp">http://www.molex.co.jp</a>	
DYDEN CORPORATION	+81-3-5805-5880 <a href="http://www.dyden.co.jp/english/index.htm">http://www.dyden.co.jp/english/index.htm</a>	Cable

\* The above list is for reference only. We may change the manufacturer without notice.

---

MEMO

## Contents

<b>A5 Family</b> .....	<b>247</b>
EC Directives .....	247
Conformity to UL Standards.....	247
Composition of Peripheral Equipments .....	249
<b>E Series</b> .....	<b>255</b>
Compliance to EC and EMC Directives .....	255
Composition of Peripheral Components .....	255
Conformity to UL Standards.....	256
<b>Motor capacity selection software</b> .....	<b>257</b>
AC Servo Motor Capacity Selection Software .....	257
Option Selection Software for AC Servo Motor.....	257
<b>Guide to the International System of Units (SI)</b> .....	<b>258</b>
<b>Selecting Motor Capacity</b> .....	<b>260</b>
<b>Request Sheet for Motor Selection</b> .....	<b>266</b>
<b>Connection Between Driver and Controller</b> .....	<b>274</b>
Connection Between A5 Family Driver and Controller.....	274
Replacing Old Model Servo Driver with MINAS A5II and A5 Series .....	279
Connection Between E Series Driver and Controller. ....	283
Index.....	288
Sales Office .....	305

EC Directives

The EC Directives apply to all such electronic products as those having specific functions and have been exported to EU and directly sold to general consumers. Those products are required to conform to the EU unified standards and to furnish the CE marking on the products.  
 However, our AC servos meet the relevant EC Directives for Low Voltage Equipment so that the machine or equipment comprising our AC servos can meet EC Directives.

EMC Directives

MINAS Servo System conforms to relevant standard under EMC Directives setting up certain model (condition) with certain locating distance and wiring of the servo motor and the driver. And actual working condition often differs from this model condition especially in wiring and grounding. Therefore, in order for the machine to conform to the EMC Directives, especially for noise emission and noise terminal voltage, it is necessary to examine the machine incorporating our servos.

Conformity to UL Standards

Observe the following conditions of (1) and (2) to make the system conform to UL508C (E164620).  
 (1) Use the driver in an environment of Pollution Degree 2 or 1 prescribed in IEC60664-1.  
 (e.g. Install in the control box with IP54 enclosure.)  
 (2) Make sure to install a circuit breaker or fuse which are UL recognized (Listed  $\text{UL}$  marked) between the power supply and the noise filter.  
 For rated current of circuit breaker and fuse, refer to P.19 "Driver and List of Applicable Peripheral Equipments".  
 Use a copper cable with temperature rating of 75 °C or higher.  
 (3) Over-load protection level  
 Over-load protective function will be activated when the effective current exceeds 115 % or more than the rated current based on the time characteristics (see the graph). Confirm that the effective current of the driver does not exceed the rated current.

Set up the peak permissible current with Pr0.13 (Setup of 1st torque limit) and Pr5.22 (Setup of 2nd torque limit).

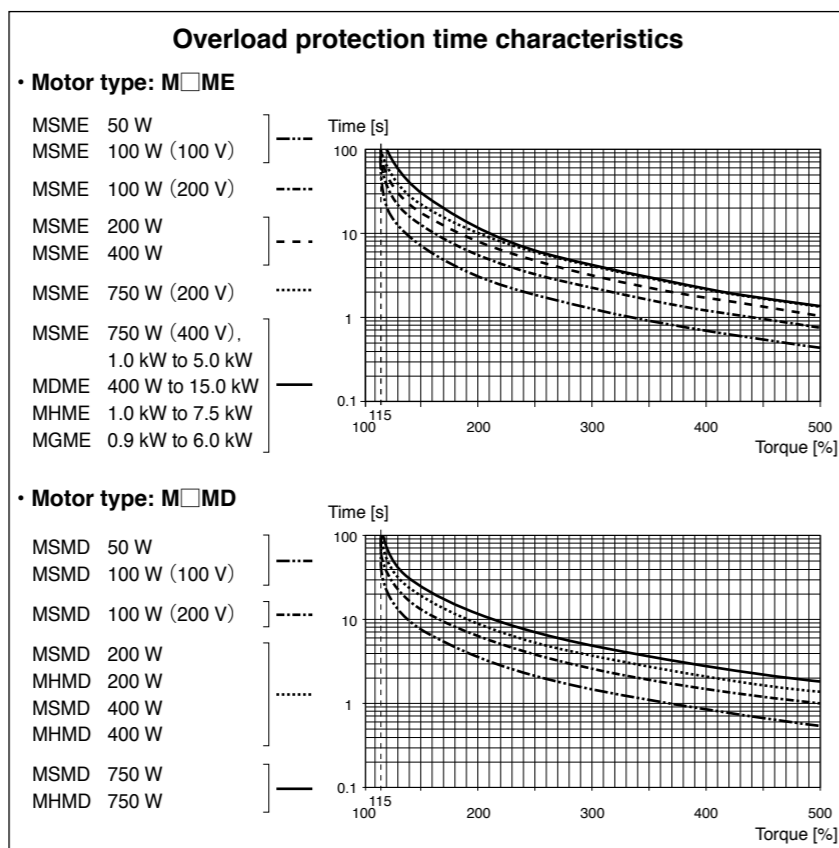

Conformed Standards

	Driver	Motor
EC Directives	EMC Directives	EN55011 EN61000-6-2 EN61800-3
	Low-Voltage Directives	EN61800-5-1
	Machinery Directives Functional safety *1	ISO13849-1(PL d)(Cat.3) EN61508(SIL2) EN62061(SILCL 2) EN61800-5-2(STO) IEC61326-3-1
UL Standards	UL508C (E164620)	UL1004-1 (E327868: 50 W to 750 W 6.0 kW to 15.0 kW) UL1004 (E327868: 400 W(400 V), 600 W(400 V), 750 W(400 V), 0.9 kW to 5.0 kW)
CSA Standards	C22.2 No.14	C22.2 No.100
Korea Radio Law (KC) *2	KN11 KN61000-4-2, 3, 4, 5, 6, 8, 11	—

IEC : International Electrotechnical Commission  
 EN : Europaischen Normen  
 EMC : Electromagnetic Compatibility  
 UL : Underwriters Laboratories  
 CSA : Canadian Standards Association

Pursuant to the directive 2004/108/EC, article 9(2)  
 Panasonic Testing Centre  
 Panasonic Service Europe, a division of  
 Panasonic Marketing Europe GmbH  
 Winsbergring 15, 22525 Hamburg, F.R. Germany

● When export this product, follow statutory provisions of the destination country.

\*1 A5IIE and A5E series doesn't correspond to the functional safety standard.

\*2 Information related to the Korea Radio Law

This servo driver is a Class A commercial broadcasting radio wave generator not designed for home use. The user and dealer should be aware of this fact.

A 급 기기 (업무용 방송통신기자재)  
 이 기기는 업무용(A 급) 전자파적합기기로서 판매자 또는 사용자는 이 점을 주의하시기 바라며, 가정외의 지역에서 사용하는 것을 목적으로 합니다.

( 대상기종 : Servo Driver )

Installation Environment

Use the servo driver in the environment of Pollution Degree 1 or 2 prescribed in IEC-60664-1 (e.g. Install the driver in control panel with IP54 protection structure.)

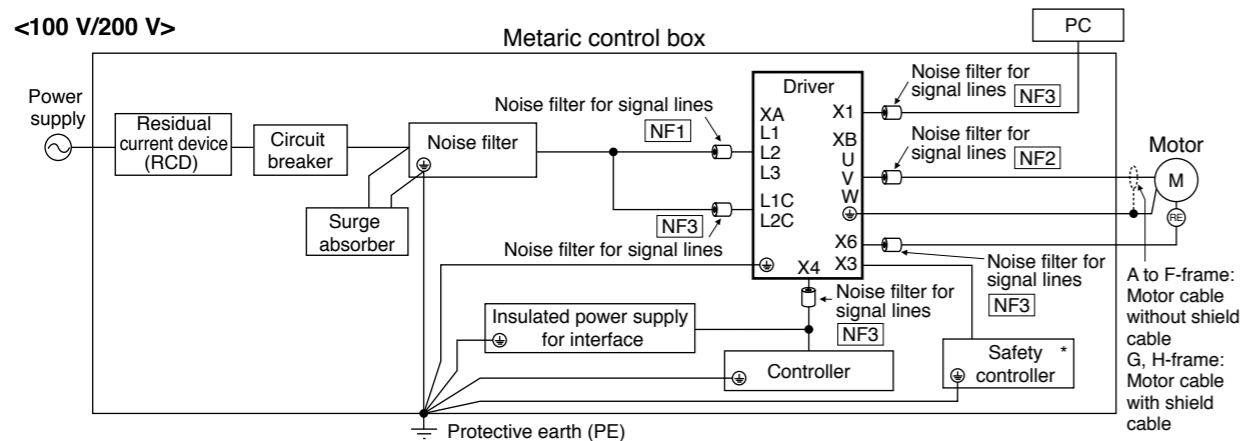

For [NF1] to [NF3], refer to the Table "Noise Filter for Signal Line" (P.254).  
\* A5IE, A5E is not provided with X3 terminal.

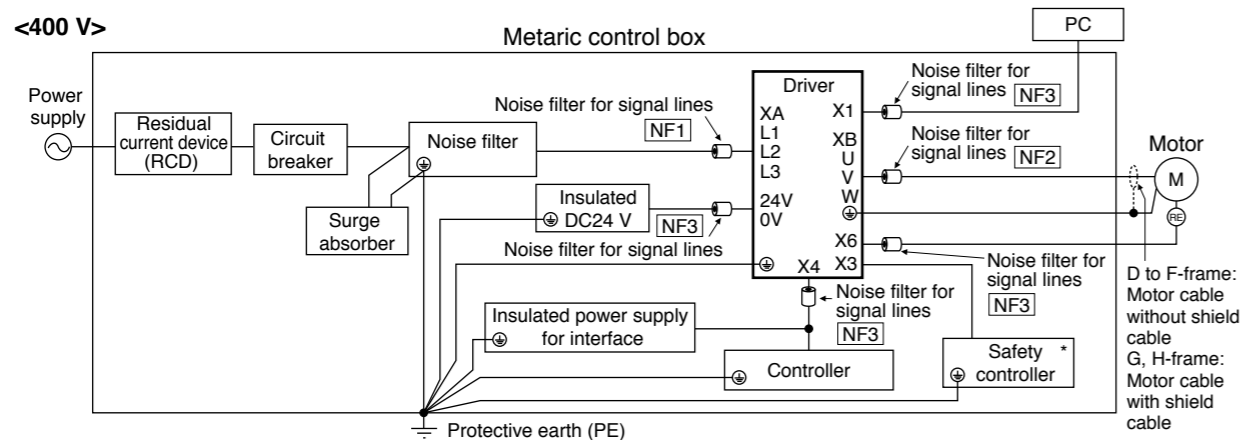

For [NF1] to [NF3], refer to the Table "Noise Filter for Signal Line" (P.254).  
\* A5IE, A5E is not provided with X3 terminal.

<Caution>

Use options correctly after reading Operating Instructions of the options to better understand the precautions. Take care not to apply excessive stress to each optional part.

Power Supply

100 V type (A to C-frame)	Single phase, 100 V $+10\%$ to $-15\%$	120 V $+10\%$ to $-15\%$	50/60 Hz
200 V type (A to D-frame)	Single/3-phase, 200 V $+10\%$ to $-15\%$	240 V $+10\%$ to $-15\%$	50/60 Hz
200 V type (E to H-frame)	3-phase, 200 V $+10\%$ to $-15\%$	230 V $+10\%$ to $-15\%$	50/60 Hz
400 V type [Main power supply] (D to H-frame)	3-phase, 380 V $+10\%$ to $-15\%$	480 V $+10\%$ to $-15\%$	50/60 Hz
400 V type [Control power supply] (D to H-frame)	DC 24 V $\pm 15\%$		

- (1) This product is designed to be used in over-voltage category (installation category) III of EN 61800-5-1:2007.
- (2) Use an insulated power supply of DC12 V to 24 V which has CE marking or complies with EN60950.

Circuit Breaker

Install a circuit breaker which complies with IEC Standards and UL recognized (Listed and marked) between power supply and noise filter.

The short-circuit protection circuit on the product is not for protection of branch circuit.

The branch circuit should be protected in accordance with NEC and the applicable local regulations in your area.

Noise Filter

When you install one noise filter at the power supply for multi-axes application, contact the manufacturer of the noise filter. If noise margin is required, connect 2 filters in series to emphasize effectiveness.

Options

Option part No.	Voltage specifications for driver	Manufacturer's part No.	Applicable driver (frame)	Manufacturer
DV0P4170	Single phase 100 V, 200 V	SUP-EK5-ER-6	A and B-frame	Okaya Electric Ind.

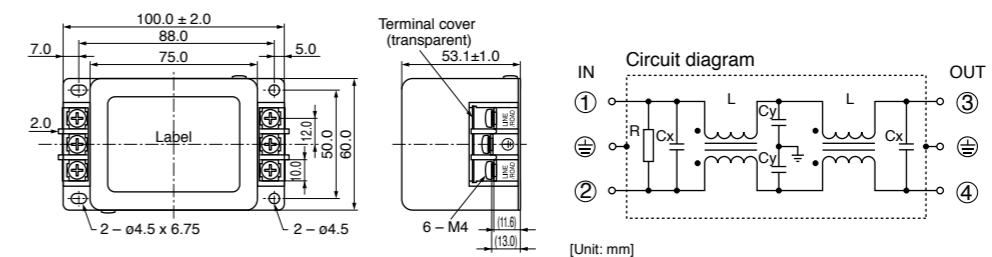

Option part No.	Voltage specifications for driver	Manufacturer's part No.	Applicable driver (frame)	Manufacturer
DV0PM20042	3-phase 200 V	3SUP-HU10-ER-6	A and B-frame	Okaya Electric Ind.
DV0P4220	Single/3-phase 200 V		C-frame	
DV0PM20043	3-phase 200 V	3SUP-HU50-ER-6	E-frame	

[DV0PM20042, DV0P4220]

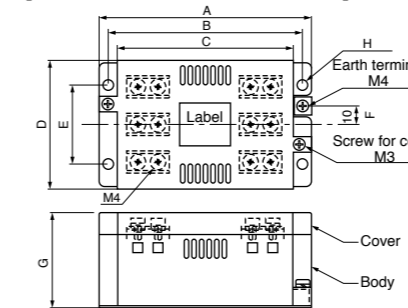

[DV0PM20043]

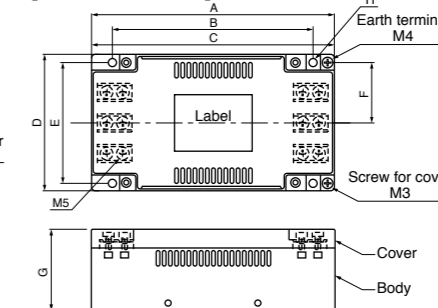

[Size]	A	B	C	D	E	F	G	H
DV0PM20042	115	105	95	70	43	10	52	5.5
DV0P4220	145	135	125	70	50	10	52	5.5
DV0PM20043	165	136	165	90	80	40	54	5.5

For single phase application, use 2 terminals among 3 terminals, leaving the remaining terminal unconnected.

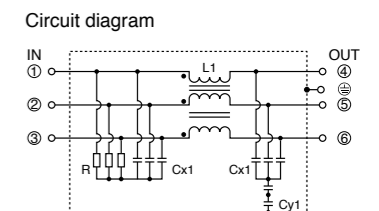

Option part No.	Voltage specifications for driver	Manufacturer's part No.	Applicable driver (frame)	Manufacturer
DV0P3410	3-phase 200 V	3SUP-HL50-ER-6B	F-frame	Okaya Electric Ind.

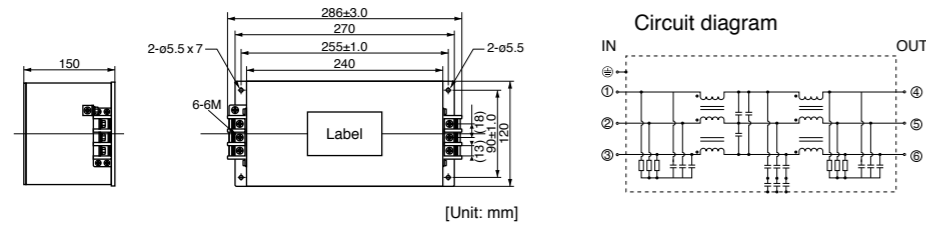

• Recommended components

Part No.	Voltage specifications for driver	Current rating (A)	Applicable driver (frame)	Manufacturer
RTHN-5010	3-phase 200 V	10	A, B, C-frame	TDK-Lambda Corp.
RTHN-5030		30	D-frame	
RTHN-5050		50	E, F-frame	

[RTHN-5010]

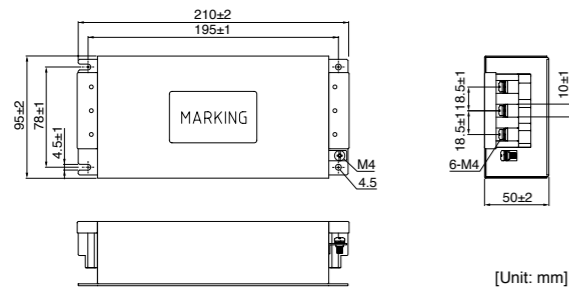

[RTHN-5030]

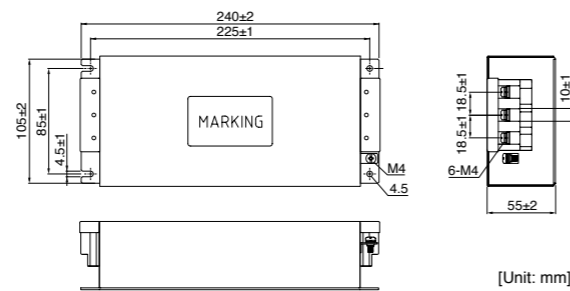

[RTHN-5050]

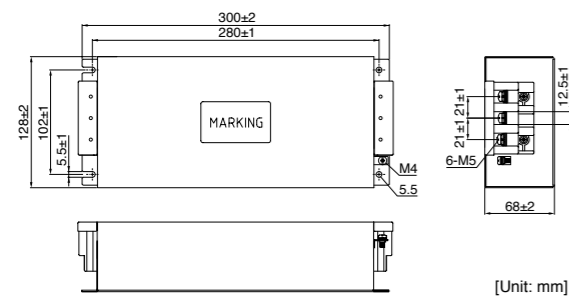

<Remarks>

- Select a noise filter of capacity that exceeds the capacity of the power source (also check for load condition).
- For detailed specification of the filter, contact the manufacturer.
- When two or more servo drivers are used with a single noise filter at the common power source, consult with the noise filter manufacturer.

Part No.	Voltage specifications for driver	Current rating (A)	Applicable driver (frame)	Manufacturer
FS5559-60-34	3-phase 200 V	60	G-frame	Schaffner EMC, Inc.
FS5559-80-34		80	H-frame	
FN258L-16-07	3-phase 400 V	16	D, E-frame	
FN258L-30-07		30	F-frame	
FN258-42-07		42	G, H-frame	
FN258-42-33		42		

[FS5559-60-34, FS5559-80-34]

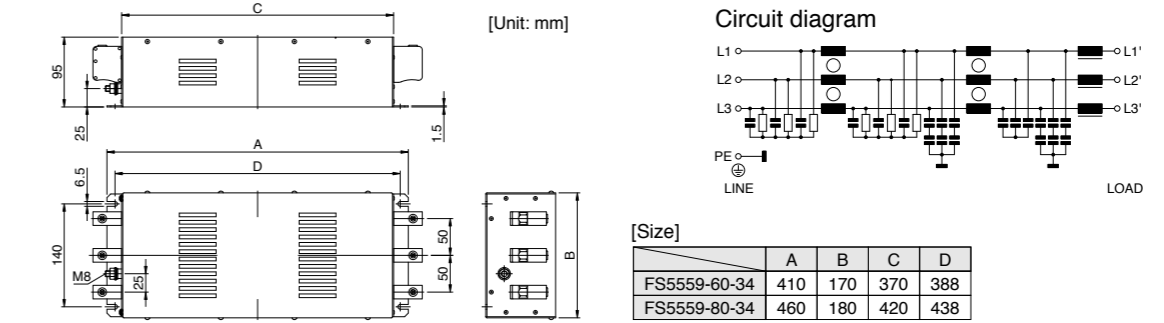

[FN258L-16-07]

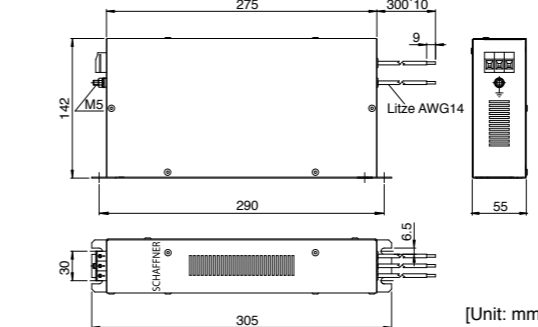

Circuit diagram

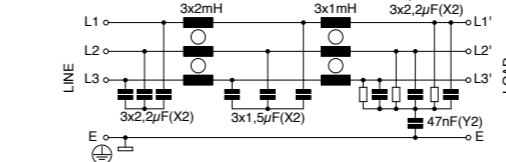

[FN258L-30-07]

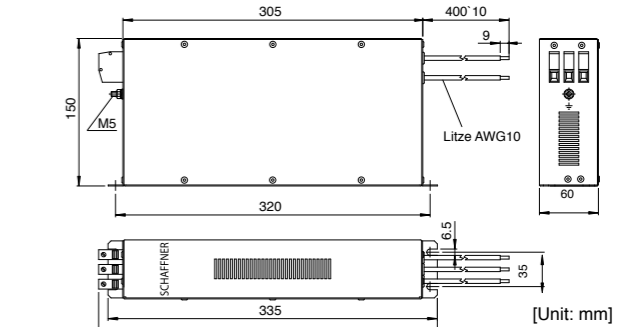

Circuit diagram

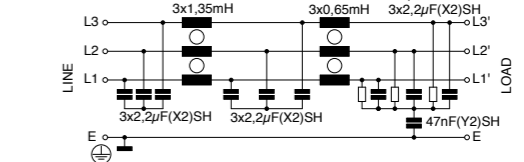

[FN258-42-07]

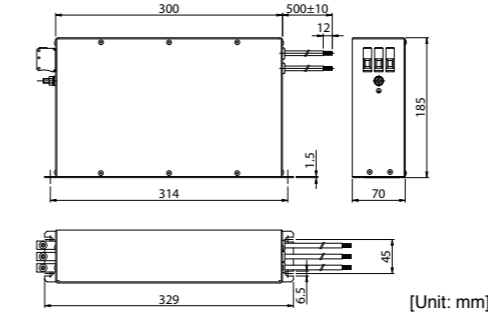

Circuit diagram

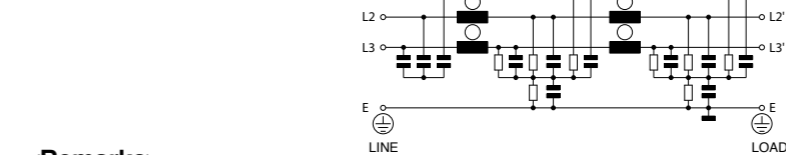

[FN258-42-33]

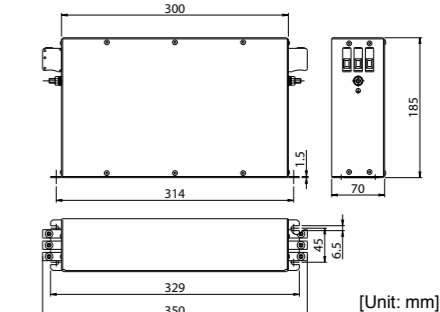

<Remarks>

- Select a noise filter of capacity that exceeds the capacity of the power source (also check for load condition).
- For detailed specification of the filter, contact the manufacturer.
- When two or more servo drivers are used with a single noise filter at the common power source, consult with the noise filter manufacturer.



Surge Absorber

Provide a surge absorber for the primary side of noise filter.

Option part No.	Voltage specifications for driver	Manufacturer's part No.	Manufacturer
DV0P1450	3-phase 200 V	R·A·V-781BXZ-4	Okaya Electric Ind.
DV0PM20050	3-phase 400 V	R·A·V-801BXZ-4	

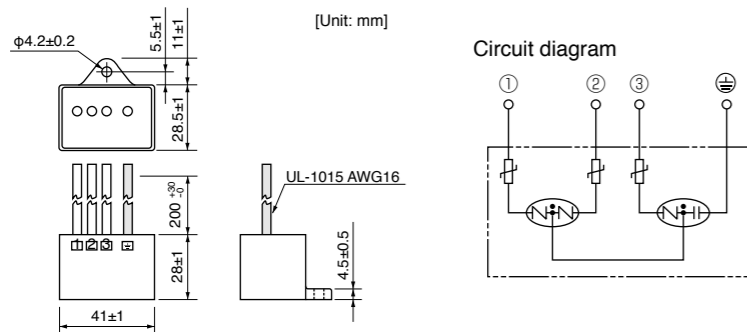

Option part No.	Voltage specifications for driver	Manufacturer's part No.	Manufacturer
DV0P4190	Single phase 100 V, 200 V	R·A·V-781BWZ-4	Okaya Electric Ind.

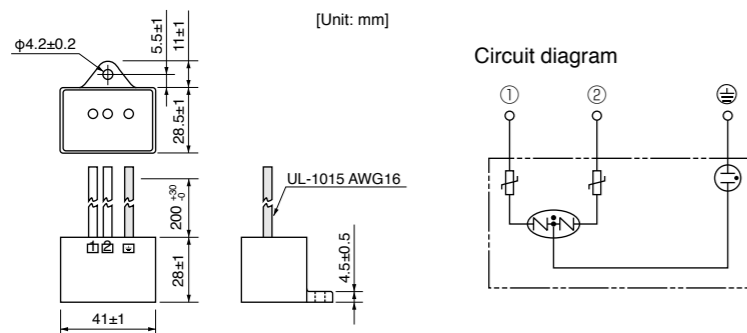

Noise Filter for Signal Lines

Install noise filters for signal lines to all cables (power cable, motor cable, encoder cable and interface cable)

Symbol <sup>*1</sup>	Cable Name	100 V/200 V Amp. frame symbol	400 V Amp. frame symbol	Option part No.	Manufacturer's part No.	Manufacturer	Qty.
NF1	Power cable	A, B, C, D	D, E, F	DV0P1460	ZCAT3035-1330	TDK Corp.	4
		E, F	—	Recommended components	RJ8035	KK-CORP.CO.JP	1
		G, H	G, H	Recommended components	RJ8095	KK-CORP.CO.JP	1
NF2	Motor cable	A, B, C, D, E, F	D, E, F	DV0P1460	ZCAT3035-1330	TDK Corp.	4
		G, H	G, H	Recommended components	T400-61D	MICROMETALS	1
NF3	<ul style="list-style-type: none"> <li>24 V Power cable</li> <li>Encoder cable</li> <li>Interface cable</li> <li>USB cable</li> <li>Control power cable</li> </ul>	Common (to all frames)		DV0P1460	ZCAT3035-1330	TDK Corp.	4

\*1 For symbols, refer to the Block Diagram "Installation Environment" (P.249).

<Remarks>

To connect the noise filter to the connector XB connection cable, adjust the sheath length at the tip of the cable, as required.

<Caution>

Fix the signal line noise filter in order to prevent excessive stress to the cables.

<Fig.2: Dimensions>

Part No.	Current	100 kHz (μH)	Size [Unit: mm]							
			A	B	C	D1	D2	Core thickness	E	F
RJ8035	35 A	9.9±3	170	150	23	80	53	24	R3.5	7
RJ8095	95 A	7.9±3	200	180	34	130	107	35	R3.5	7

Fig.1: DV0P1460(OPTION)

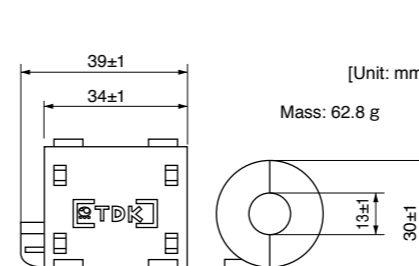

Fig.2: RJ8035, RJ8095 (Recommended components)

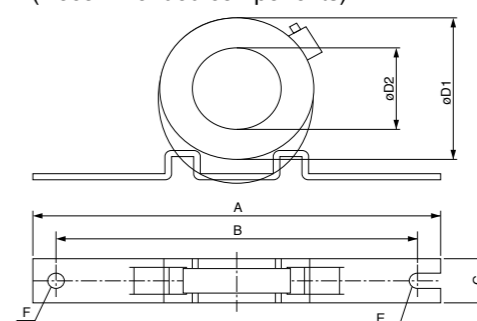
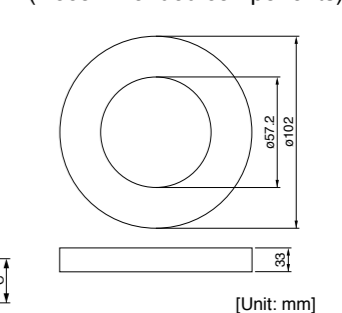

Fig.3: T400-61D (Recommended components)



Residual Current Device

Install a type B Residual current device (RCD) at primary side of the power supply.

Type B: Residual current device which detects a direct-current ingredient.

Grounding

(1) Connect the protective earth terminal (⊕) of the driver and the protective earth terminal (PE) of the control box without fail to prevent electrical shocks.

(2) Do not make a joint connection to the protective earth terminals (⊕). 2 terminals are provided for protective earth.

<Note>

For driver and applicable peripheral equipments, refer to P.19 "Driver and List of Applicable Peripheral Equipments".

Compliance to EC and EMC Directives

EC Directives

The EC Directives apply to all such electronic products as those having specific functions and have been exported to EU and directly sold to general consumers. Those products are required to conform to the EU unified standards and to furnish the CE marking on the products. MINAS AC Servos conforms to the EC Directives for Low Voltage Equipment so that the machine incorporating our servos has an easy access to the conformity to relevant EC Directives for the machine.

EMC Directives

MINAS Servo System conform to relevant standard under EMC Directives setting up certain model (condition) with certain locating distance and wiring of the servo motor and the driver. And actual working condition often differs from this model condition especially in wiring and grounding. Therefore, in order for the machine to conform to the EMC Directives, especially for noise emission and noise terminal voltage, it is necessary to examine the machine incorporating our servos.

Conformed Standards

Subject	Conformed Standard		Conforms to Low-Voltage Directives
Motor	IEC60034-1	IEC60034-5 UL1004 CSA22.2 No.100	
	EN50178	UL508C CSA22.2 No.14	
Motor and driver	EN55011	Radio Disturbance Characteristics of Industrial, Scientific and Medical (ISM) Radio-Frequency Equipment	Conforms to references by EMC Directives
	EN61000-6-2	Immunity for Industrial Environments	
	IEC61000-4-2	Electrostatic Discharge Immunity Test	
	IEC61000-4-3	Radio Frequency Electromagnetic Field Immunity Test	
	IEC61000-4-4	Electric High-Speed Transition Phenomenon/Burst Immunity Test	
	IEC61000-4-5	Lightening Surge Immunity Test	
	IEC61000-4-6	High Frequency Conduction Immunity Test	
	IEC61000-4-11	Instantaneous Outage Immunity Test	

IEC : International Electrotechnical Commission  
EN : Europaischen Normen  
EMC: Electromagnetic Compatibility  
UL : Underwriters Laboratories  
CSA : Canadian Standards Association

Pursuant to at the directive 2004/108/EC, article 9(2)  
Panasonic Testing Centre  
Panasonic Service Europe,  
a division of Panasonic Marketing Europe GmbH  
Winsbergring 15,22525 Hamburg,F.R.Germany

Composition of Peripheral Components

<Precautions in using options>

Use options correctly after reading operation manuals of the options to better understand the precautions. Take care not to apply excessive stress to each optional part.

Installation Environment

Use Minas driver in environment of Pollution Degree 1 or 2 prescribed in IEC-60664-1 (e.g. Install the driver in control panel with IP54 protection structure.)

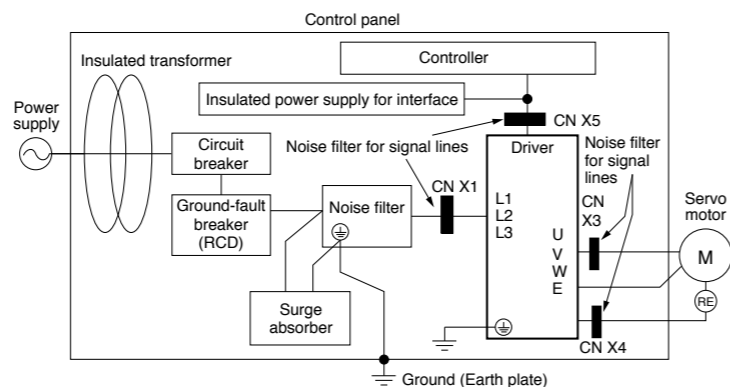

Power Supply

100 V system	Single phase, 100 V	+10 % -15 %	to	115 V	+10 % -15 %	50/60 Hz
200 V system	Single phase, 200 V	+10 % -15 %	to	240 V	+10 % -15 %	50/60 Hz
200 V system	3-phase, 200 V	+10 % -15 %	to	240 V	+10 % -15 %	50/60 Hz

- (1) Use the power supply under an environment of Overvoltage Category II specified in IEC60664-1.
- (2) For a interface power supply, use the insulated one with 12 to 24 VDC which conforms to CE Marking or EN Standards (EN60950).

Circuit Breaker

Connect a circuit breaker which conforms to IEC standards and is UL recognized (UL Listed, marked), between the power supply and the noise filter.

Noise Filter

When you install one noise filter in the power supply for multi axis application, consult with the manufacture of the filter.

Option part No.	Part No.	Manufacturer
DV0P4160	3SUP-HU10-ER-6	Okaya Electric Industries Co.

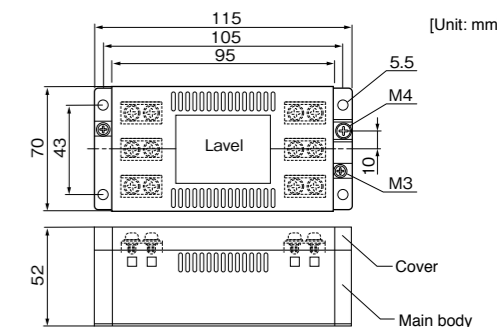

Surge Absorber

Install a surge absorber at primary side of the noise filter.

Option part No.	Driver voltage spec	Part No.	Manufacturer
DV0P1450	3-phase, 200 V	R·A·V-781BXZ-4	Okaya Electric

Option part No.	Driver voltage spec	Part No.	Manufacturer
DV0P4190	Single phase, 100 V, 200 V	R·A·V-781BWZ-4	Okaya Electric

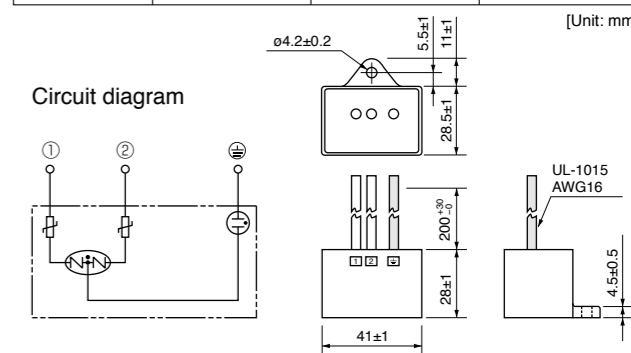
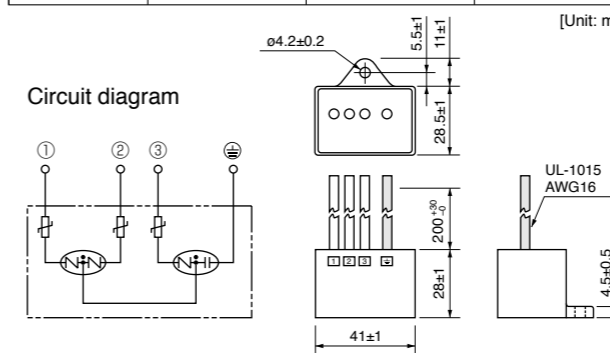

<Remarks>

Remove this surge absorber when you perform dielectric test on the machine, or surge absorber might be damaged.

Noise Filter for Signal Lines

Install noise filters for signal lines to all cables (Power line, motor cable, encoder cable, interface cable)

<Caution>

- Please fix a line noise filter to avoid excessive stress to the cable.
  - When using multiple axes, noise generated from each driver might influence driver and peripheral equipment and result to malfunction.
- Please insert line noise filters between driver and motor wires (U, V, W but grounding).  
(Please refer to P.255 "peripheral equipment configuration".)

Option part No.	Part No.	Qty.	Manufacturer
DV0P1460	ZCAT3035-1330	4	TDK Corp.

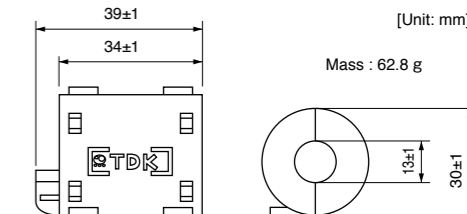

Grounding

- (1) Connect the protective earth terminal of the driver () and protective earth terminal of the control panel (PE) without fail to prevent electrical shocks.
- (2) Do not co-clamp to the ground terminals (). Two ground terminals are provided.

Ground-Fault Breaker

Install a ground fault circuit breaker (RCD) to the primary side of the power supply. Please use B-type (DC sensitive) ground fault circuit breakers defined in IEC60947-2, JISC8201-2-2.

Conformity to UL Standards

- Observe the following conditions of (1) and (2) to make the system conform to UL508C (File No. E164620).
- (1) Use the driver in an environment of Pollution Degree 2 or 1 prescribed in IEC60664-1. (e.g. Install in the control box with IP54 enclosure.)
  - (2) Install a circuit breaker or fuse which are UL recognized (LISTED marked) between the power supply and the noise filter without fail.

AC Servo Motor Capacity Selection Software

We have prepared PC software "M-SELECT" for AC servo motor capacity selection. Consult our sales representative or authorized distributor.

• Three-step selection

1. Select components and specified values

Select appropriate mechanical parameter items and fill them with parameter values derived from the real machine. To simulate the target machine as practical as possible, use maximum number of parameters available.



2. Enter operation pattern

Input the planned operation pattern that will contain [speed and rotation standard] or [absolute position standard] with optional settings such as S-acceleration/deceleration.



3. Select the motor

When the data required in step 1 and 2 above have been input, the software lists the motors, which will be appropriate to use with your machine. Select the motor that is best suitable for your machine application.



➔ Details of motor

Once the motor is selected, specifications of the motor and amplifier, and details of reason for determination are displayed and may be printed out.

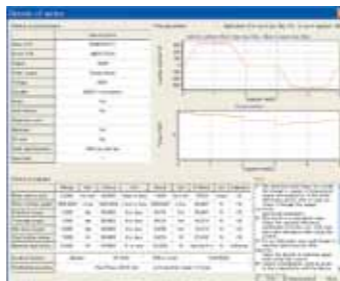

Option Selection Software for AC Servo Motor

We have prepared PC software to enable fast, easy, and correct option selection, a complicated job without the software.

• Two procedures for option selection

1. Selection according to driver series and motor type

Suitable option can be selected by selecting driver series, motor type and motor specification through pulldown menu.

Driver series

Motor type

Motor specification

Model number input area

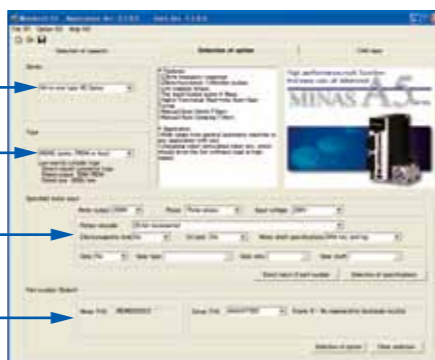

2. Entry of model number

If you know the model number based on the servo motor and driver currently used, enter the model number.

Tab

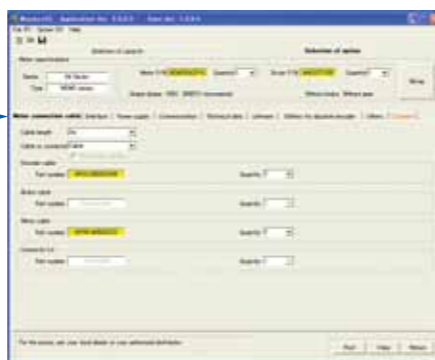

➔ Result of selection

Tab sheet specific to each of option model numbers is used for easier identification of the desired option.

\* When you are using the motor capacity selection software, simply press [Option Selection] tab and the screen as shown right will appear.

Please download from our web site and use after install to the PC.  
[http://industrial.panasonic.com/ww/i\\_e/25000/motor\\_fa\\_e/motor\\_fa\\_e.html](http://industrial.panasonic.com/ww/i_e/25000/motor_fa_e/motor_fa_e.html)

Organization of the System of Units

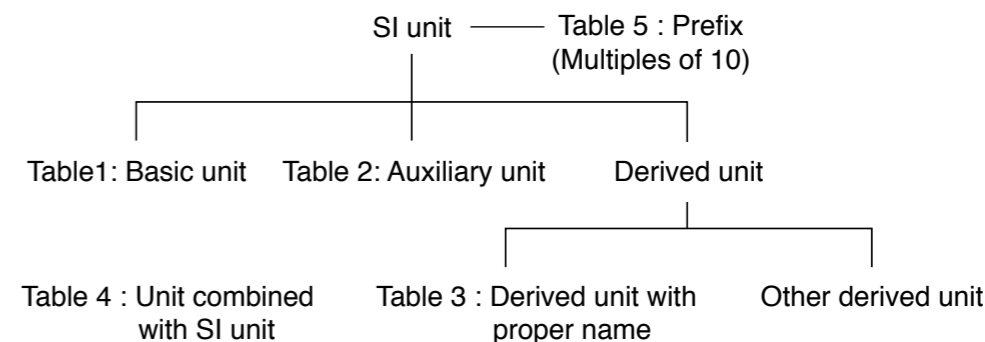

Table 1: Basic unit

Quantity	Name of unit	Symbol of unit
Length	meter	m
Weight	kilogram	kg
Time	second	s
Current	ampere	A
Thermodynamic temperature	kelvin	K
Amount of substance	mol	mol
Luminous intensity	candela	cd

Table 2: Auxiliary unit

Quantity	Name of unit	Symbol of unit
Plane angle	radian	rad
Solid angle	steradian	sr

Table 3: Major derived unit with proper name

Quantity	Name	Symbol of unit	Derivation from basic unit, auxiliary unit or other derived unit
Frequency	hertz	Hz	1 Hz = 1 s <sup>-1</sup>
Force	newton	N	1 N = 1 kg·m/s <sup>2</sup>
Pressure, Stress	pascal	Pa	1 Pa = 1 N/m <sup>2</sup>
Energy, Work, Amount of heat	joule	J	1 J = 1 N·m
Amount of work, Work efficiency, Power, Electric power	watt	W	1 W = 1 J/s
Electric charge, Amount of electricity	coulomb	C	1 C = 1 A·s
Electric potential, Potential difference, Voltage, Electromotive force	volt	V	1 V = 1 J/C
Electrostatic capacity, Capacitance	farad	F	1 F = 1 C/V
Electric resistance	ohm	Ω	1 Ω = 1 V/A
Electric conductance	siemens	S	1 S = 1 Ω <sup>-1</sup>
Magnetic flux	weber	Wb	1 Wb = 1 V·s
Magnetic flux density, Magnetic induction	tesla	T	1 T = 1 Wb/m <sup>2</sup>
Inductance	henry	H	1 H = 1 Wb/A
Degree centigrade (Celsius)	degree centigrade (Celsius) / degree	°C	t °C = (t+273.15) K
Luminous flux	lumen	lm	1 lm = 1 cd·sr
Illuminance	lux	lx	1 lx = 1 lm/m <sup>2</sup>

Table 4: Unit combined with SI unit

Quantity	Name	Symbol of unit
Time	minute	min
	hour	h
	day	d
Plane angle	degree	°
	minute	'
	second	"
Volume	liter	l, L
Weight	ton	t

Table 5: Prefix

Multiples powered to unit	Prefix	
	Name	Symbol
10 <sup>18</sup>	exa	E
10 <sup>15</sup>	peta	P
10 <sup>12</sup>	tera	T
10 <sup>9</sup>	giga	G
10 <sup>6</sup>	mega	M
10 <sup>3</sup>	kilo	k
10 <sup>2</sup>	hecto	h
10	deca	da
10 <sup>-1</sup>	deci	d
10 <sup>-2</sup>	centi	c
10 <sup>-3</sup>	milli	m
10 <sup>-6</sup>	micro	μ
10 <sup>-9</sup>	nano	n
10 <sup>-12</sup>	pico	p
10 <sup>-15</sup>	femto	f
10 <sup>-18</sup>	atto	a

Quantity	Symbol of conventional unit	Symbol of SI unit and compatible unit	Conversion value
Length	μ (micron)	μm	1 μ = 1 μm (micrometer)
Acceleration	Gal G	m/s <sup>2</sup> m/s <sup>2</sup>	1 Gal = 10 <sup>-2</sup> m/s <sup>2</sup> 1 G = 9.80665 m/s <sup>2</sup>
Frequency	c/s, c	Hz	1 c/s = Hz
Revolving speed, Number of revolutions	rpm	s <sup>-1</sup> or min <sup>-1</sup> , r/min	1 rpm = 1 min <sup>-1</sup>
Weight	kgf	-	} Same value
Mass	-	kg	
Weight flow rate	kgf/s	-	} Same value
Mass flow rate	-	kg/s	
Specific weight	kgf/m <sup>3</sup>	-	} Same value
Density	-	kg/m <sup>3</sup>	
Specific volume	m <sup>3</sup> /kgf	m <sup>3</sup> /kg	Same value
Load	kgf	N	1 kgf = 9.80665 N
Force	kgf dyn	N N	1 kgf = 9.80665 N 1 dyn = 10 <sup>-5</sup> N
Moment of force	kgf·m	N·m	1 kgf·m = 9.806 N·m
Pressure	kgf/cm <sup>2</sup>  at (Engineering atmospheric pressure) atm (Atmospheric pressure) mH <sub>2</sub> O, mAq mmHg Torr	Pa, bar <sup>(1)</sup> or kgf/cm <sup>2</sup>  Pa Pa Pa Pa or mmHg <sup>(2)</sup> Pa	1 kgf/cm <sup>2</sup> = 9.80665 × 10 <sup>4</sup> Pa = 0.980665 bar 1 at = 9.80665 × 10 <sup>4</sup> Pa 1 atm = 1.01325 × 10 <sup>5</sup> Pa 1 mH <sub>2</sub> O = 9.80665 × 10 <sup>3</sup> Pa 1 mmHg = 133.322 Pa
Stress	kgf/mm <sup>2</sup>  kgf/cm <sup>2</sup>	Pa or N/m <sup>2</sup>  Pa or N/m <sup>2</sup>	1 kgf/mm <sup>2</sup> = 9.80665 × 10 <sup>6</sup> Pa = 9.80665 × 10 <sup>6</sup> N/m <sup>2</sup> 1 kgf/cm <sup>2</sup> = 9.80665 × 10 <sup>4</sup> Pa = 9.80665 × 10 <sup>4</sup> N/m <sup>2</sup>
Elastic modulus	kgf/m <sup>2</sup>	Pa or N/m <sup>2</sup>	1 kgf/m <sup>2</sup> = 9.80665 Pa = 9.80665 N/m <sup>2</sup> 1 kgf/cm <sup>2</sup> = 9.80665 × 10 <sup>4</sup> N/m <sup>2</sup>
Energy, Work	kgf·m erg	J (joule) J	1 kgf·m = 9.80665 J 1 erg = 10 <sup>-7</sup> J
Work efficiency, Power	kgf·m/s PS	W (watt) W	1 kgf·m/s = 9.80665 W 1 PS = 0.7355 kW
Viscosity	PP	Pa·s	1 P = 0.1 Pa·s
Kinetic viscosity	St	mm <sup>2</sup> /s	10 <sup>-2</sup> St = 1 mm <sup>2</sup> /s
Thermodynamic temperature	K	K (kelvin)	1 K = 1 K
Temperature interval	deg	K <sup>(3)</sup>	1 deg = 1 K
Amount of heat	cal	J	1 cal = 4.18605 J
Heat capacity	cal/°C	J/K <sup>(3)</sup>	1 cal/°C = 4.18605 J/K
Specific heat, Specific heat capacity	cal/(kgf·°C)	cal/(kgf·K) <sup>(3)</sup>	1 cal/(kgf·°C) = 4.18605 J/(kg·K)
Entropy	cal/K	J/K	1 cal/K = 4.18605 J/K
Specific entropy	cal/(kgf·K)	J/(kg·K)	1 cal/(kgf·K) = 4.18605 J/(kg·K)
Internal energy (Enthalpy)	cal	J	1 cal = 4.18605 J
Specific internal energy (Specific enthalpy)	cal/kgf	J/kg	1 cal/kgf = 4.18605 J/kg
Heat flux	cal/h	W	1 kcal/h = 1.16279 W
Heat flux density	cal/(h·m <sup>2</sup> )	W/m <sup>2</sup>	1 kcal/(h·m <sup>2</sup> ) = 1.16279 W/m <sup>2</sup>
Thermal conductivity	cal/(h·m·°C)	W/(m·K) <sup>(3)</sup>	1 kcal/(h·m·°C) = 1.16279 W/(m·K)
Coefficient of thermal conductivity	cal/(h·m <sup>2</sup> ·°C)	W/(m <sup>2</sup> ·K) <sup>(3)</sup>	1 kcal/(h·m <sup>2</sup> ·°C) = 1.16279 W/(m <sup>2</sup> ·K)
Intensity of magnetic field	Oe	A/m	1 Oe = 10 <sup>3</sup> / (4π) A/m
Magnetic flux	Mx	Wb (weber)	1 Mx = 10 <sup>-8</sup> Wb
Magnetic flux density	Gs, G	T (tesla)	1 Gs = 10 <sup>-4</sup> T

**Note**  
 (1) Applicable to liquid pressure. Also applicable to atmospheric pressure of meteorological data, when "bar" is used in international standard.  
 (2) Applicable to scale or indication of blood pressure manometers.  
 (3) "C" can be substituted for "K".

Flow of Motor Selection

1. Definition of mechanism to be driven by motor.

Define details of individual mechanical components (ball screw length, lead and pulley diameters, etc.)

<Typical mechanism>

Ball screw mechanism

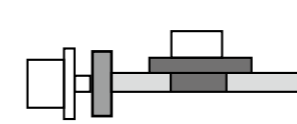

Belt mechanism

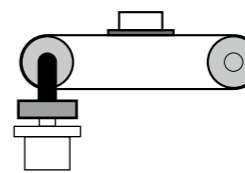

Rack & pinion, etc.

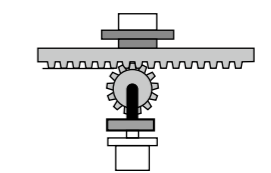

2. Definition of operating pattern.

Acceleration/deceleration time, Constant-velocity time, Stop time, Cycle time, Travel distance

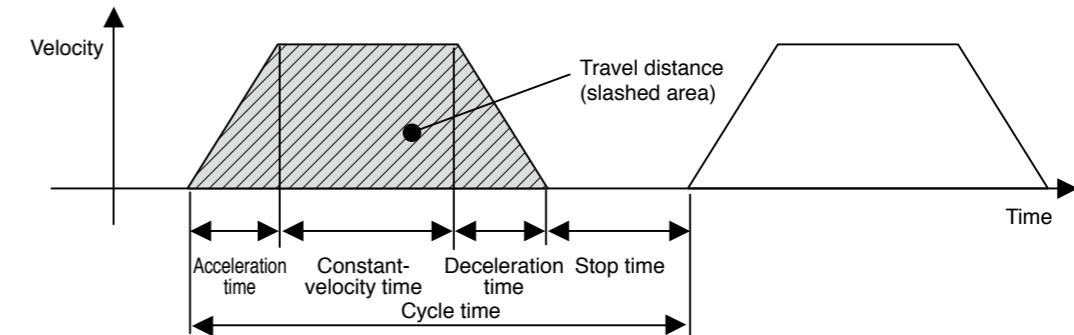

Note) Selection of motor capacity significantly varies depending on the operating pattern. The motor capacity can be reduced if the acceleration/deceleration time and stop time are set as long as possible.

3. Calculation of load inertia and inertia ratio.

Calculate load inertia for each mechanical component. (Refer to "General inertia calculation method" described later.)

Divide the calculated load inertia by the inertia of the selected motor to check the inertia ratio. For calculation of the inertia ratio, note that the catalog value of the motor inertia is expressed as "× 10<sup>-4</sup> kg·m<sup>2</sup>".

4. Calculation of motor velocity

Calculate the motor velocity from the moving distance, acceleration / deceleration time and constant-velocity time.

5. Calculation of torque

Calculate the required motor torque from the load inertia, acceleration/deceleration time and constant-velocity time.

6. Calculation of motor

Select a motor that meets the above 3 to 5 requirements.

Description on the Items Related to Motor Selection

1. Torque

(1) Peak torque

Indicate the maximum torque that the motor requires during operation (mainly in acceleration and deceleration steps). The reference value is 80% or less of the maximum motor torque. If the torque is a negative value, a regenerative discharge resistor may be required.

(2) Traveling torque, Stop holding torque

Indicates the torque that the motor requires for a long time. The reference value is 80% or less of the rated motor torque. If the torque is a negative value, a regenerative discharge resistor may be required.

Traveling torque calculation formula for each mechanism

**Ball screw mechanism**

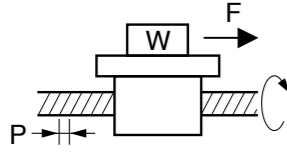

Traveling torque  $T_f = \frac{P}{2\pi\eta} (\mu g W + F)$

W : Weight [kg]       $\eta$  : Mechanical efficiency  
 P : Lead [m]       $\mu$  : Coefficient of friction  
 F : External force [N]      g : Acceleration of gravity 9.8[m/s<sup>2</sup>]

**Belt mechanism**

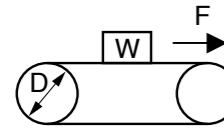

Traveling torque  $T_f = \frac{D}{2\pi\eta} (\mu g W + F)$

W : Weight [kg]       $\eta$  : Mechanical efficiency  
 P : Pulley diameter [m]       $\mu$  : Coefficient of friction  
 F : External force [N]      g : Acceleration of gravity 9.8[m/s<sup>2</sup>]

(3) Effective torque

Indicates a root-mean-square value of the total torque required for running and stopping the motor per unit time. The reference value is approx. 80% or less of the rated motor torque.

$$T_{rms} = \sqrt{\frac{T_a^2 \times t_a + T_f^2 \times t_b + T_d^2 \times t_d}{t_c}}$$

- T<sub>a</sub> : Acceleration torque [N·m]      t<sub>a</sub> : Acceleration time [s]      t<sub>c</sub> : Cycle time [s]
- T<sub>f</sub> : Traveling torque [N·m]      t<sub>b</sub> : Constant-velocity time [s]      (Run time + Stop time)
- T<sub>d</sub> : Deceleration torque [N·m]      t<sub>d</sub> : Deceleration time [s]

2. Motor velocity

Maximum velocity

Maximum velocity of motor in operation: The reference value is the rated velocity or lower value. When the motor runs at the maximum velocity, you must pay attention to the motor torque and temperature rise. For actual calculation of motor velocity, see "Example of motor selection" described later.

3. Inertia and inertia ratio

Inertia is like the force to retain the current moving condition. Inertia ratio is calculated by dividing load inertia by rotor inertia. Generally, for motors with 750 W or lower capacity, the inertia ratio should be "20" or less. For motors with 1000 W or higher capacity, the inertia ratio should be "10" or less. If you need quicker response, a lower inertia ratio is required. (For example, when the motor takes several seconds in acceleration step, the inertia ratio can be further increased.)

General inertia calculation method

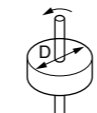
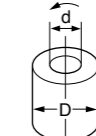
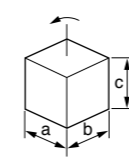
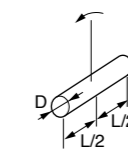
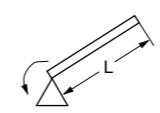
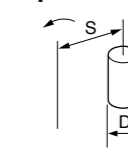
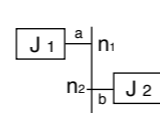
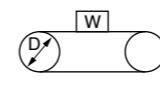
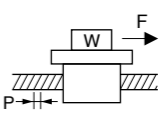
Shape	J calculation formula	Shape	J calculation formula
<b>Disk</b> 	$J = \frac{1}{8} W D^2$ [kg·m <sup>2</sup> ] W : Weight [kg] D : Outer diameter [m]	<b>Hollow cylinder</b> 	$J = \frac{1}{8} W (D^2 + d^2)$ [kg·m <sup>2</sup> ] W : Weight [kg] D : Outer diameter [m] d : Inner diameter [m]
<b>Prism</b> 	$J = \frac{1}{12} W (a^2 + b^2)$ [kg·m <sup>2</sup> ] W : Weight [kg] a, b, c : Side length [m]	<b>Uniform rod</b> 	$J = \frac{1}{48} W (3D^2 + 4L^2)$ [kg·m <sup>2</sup> ] W : Weight [kg] D : Outer diameter [m] L : Length [m]
<b>Straight rod</b> 	$J = \frac{1}{3} W L^2$ [kg·m <sup>2</sup> ] W : Weight [kg] L : Length [m]	<b>Separated rod</b> 	$J = \frac{1}{8} W D^2 + W S^2$ [kg·m <sup>2</sup> ] W : Weight [kg] D : Outer diameter [m] S : Distance [m]
<b>Reduction gear</b> 	Inertia on shaft "a" $J = J_1 + \left(\frac{n_2}{n_1}\right)^2 J_2$ [kg·m <sup>2</sup> ] n <sub>1</sub> : A rotational speed of a shaft [r/min] n <sub>2</sub> : A rotational speed of b shaft [r/min]		
<b>Conveyor</b> 	$J = \frac{1}{4} W D^2$ [kg·m <sup>2</sup> ] W : Workpiece weight on conveyor [kg] D : Drum diameter [m] * Excluding drum J	<b>Ball screw</b> 	$J = J_B + \frac{W \cdot P^2}{4\pi^2}$ [kg·m <sup>2</sup> ] W : Weight [kg] P : Lead J <sub>B</sub> : J of ball screw

If weight (W [kg]) is unknown, calculate it with the following formula:

Weight W[kg]=Density ρ [kg/m<sup>3</sup>] x Volume V[m<sup>3</sup>]

Density of each material

- Iron ρ =7.9 x 10<sup>3</sup> [kg/m<sup>3</sup>]
- Aluminum ρ =2.8 x 10<sup>3</sup> [kg/m<sup>3</sup>]
- Brass ρ =8.5 x 10<sup>3</sup> [kg/m<sup>3</sup>]

To Drive Ball Screw Mechanism

1. Example of motor selection for driving ball screw mechanism

- Workpiece weight WA = 10 [kg]
- Ball screw length BL = 0.5 [m]
- Ball screw diameter BD = 0.02 [m]
- Ball screw lead BP = 0.02 [m]
- Ball screw efficiency Bη = 0.9
- Travel distance 0.3[m]
- Coupling inertia Jc = 10 × 10<sup>-6</sup> [kg·m<sup>2</sup>] (Use manufacturer-specified catalog value, or calculation value.)

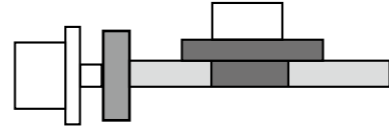

2. Running pattern :

- Acceleration time ta = 0.1 [s]
- Constant-velocity time tb = 0.8 [s]
- Deceleration time td = 0.1 [s]
- Cycle time tc = 2 [s]
- Travel distance 0.3[m]

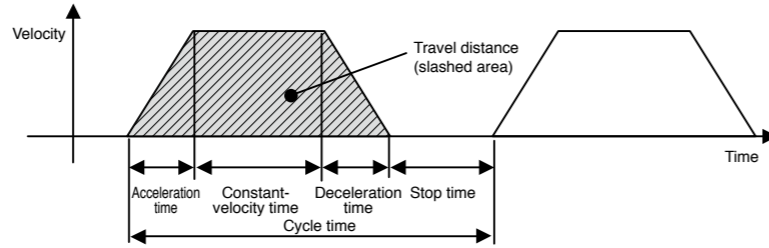

3. Ball screw weight

$$BW = \rho \times \pi \times \left(\frac{BD}{2}\right)^2 \times BL = 7.9 \times 10^3 \times \pi \times \left(\frac{0.02}{2}\right)^2 \times 0.5 = 1.24 \text{ [kg]}$$

4. Load inertia

$$JL = Jc + JB = Jc + \frac{1}{8}BW \times BD^2 + \frac{WA \cdot BP^2}{4\pi^2} = 0.00001 + (1.24 \times 0.02^2) / 8 + 10 \times 0.02^2 / 4\pi^2 = 1.73 \times 10^{-4} \text{ [kg}\cdot\text{m}^2\text{]}$$

5. Provisional motor selection

In case of MSME 200 W motor : JM = 0.14 × 10<sup>-4</sup> [kg·m<sup>2</sup>]

6. Calculation of inertia ratio

JL / JM = 1.73 × 10<sup>-4</sup> / 0.14 × 10<sup>-4</sup> Therefore, the inertia ratio is "12.3" (less than "30")  
(In case of MSME 100 W motor: JM = 0.051 × 10<sup>-4</sup> Therefore, the inertia ratio is "33.9".)

7. Calculation of maximum velocity (Vmax)

$$\frac{1}{2} \times \text{Acceleration time} \times V_{\text{max}} + \text{Constant-velocity time} \times V_{\text{max}} + \frac{1}{2} \times \text{Deceleration time} \times V_{\text{max}} = \text{Travel distance}$$

$$\frac{1}{2} \times 0.1 \times V_{\text{max}} + 0.8 \times V_{\text{max}} + \frac{1}{2} \times 0.1 \times V_{\text{max}} = 0.3$$

$$0.9 \times V_{\text{max}} = 0.3$$

$$V_{\text{max}} = 0.3 / 0.9 = 0.334 \text{ [m/s]}$$

8. Calculation of motor velocity (N [r/min]) Ball screw lead per resolution: BP = 0.02 [m]

$$N = 0.334 / 0.02 = 16.7 \text{ [r/s]}$$

$$= 16.7 \times 60 = 1002 \text{ [r/min]} < 3000 \text{ [r/min]} \text{ (Rated velocity of MSME 200W motor)}$$

9. Calculation of torque

Traveling torque  $T_f = \frac{BP}{2\pi B\eta} (\mu g WA + F) = \frac{0.02}{2\pi \times 0.9} (0.1 \times 9.8 \times 10 + 0) = 0.035 \text{ [N}\cdot\text{m]}$

Acceleration torque  $T_a = \frac{(JL + JM) \times 2\pi N [\text{r/s}]}{\text{Acceleration time [s]}} + \text{Traveling torque}$

$$= \frac{(1.73 \times 10^{-4} + 0.14 \times 10^{-4}) \times 2\pi \times 16.7}{0.1} + 0.035 = 0.196 + 0.035 = 0.231 \text{ [N}\cdot\text{m]}$$

Deceleration torque  $T_d = \frac{(JL + JM) \times 2\pi N [\text{r/s}]}{\text{Deceleration time [s]}} - \text{Traveling torque}$

$$= \frac{(1.73 \times 10^{-4} + 0.14 \times 10^{-4}) \times 2\pi \times 16.7}{0.1} - 0.035 = 0.196 - 0.035 = 0.161 \text{ [N}\cdot\text{m]}$$

10. Verification of maximum torque

Acceleration torque = Ta = 0.231 [N·m] < 1.91 [N·m] (Maximum torque of MSME 200 W motor)

11. Verification of effective torque

$$T_{\text{rms}} = \sqrt{\frac{T_a^2 \times t_a + T_f^2 \times t_b + T_d^2 \times t_d}{t_c}}$$

$$= \sqrt{\frac{0.231^2 \times 0.1 + 0.035^2 \times 0.8 + 0.161^2 \times 0.1}{2}} = 0.067 \text{ [N}\cdot\text{m]} < 0.64 \text{ [N}\cdot\text{m]} \text{ (Rated torque of MSME 200 W motor)}$$

12. Judging from the inertia ratio calculated above, selection of 200 W motor is preferable, although the torque margin is significantly large.

Example of Motor Selection

Example of motor selection for timing belt mechanism

1. Mechanism
- Workpiece weight WA = 2[kg] (including belt)
  - Pulley diameter PD = 0.05[m]
  - Pulley weight WP = 0.5[kg] (Use manufacturer-specified catalog value, or calculation value.)
  - Mechanical efficiency Bη = 0.8
  - Coupling inertia Jc = 0 (Direct connection to motor shaft)
  - Belt mechanism inertia JB
  - Pulley inertia JP

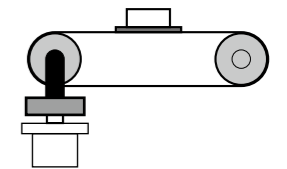

2. Running pattern

- Acceleration time ta = 0.1[s]
- Constant-velocity time tb = 0.8[s]
- Deceleration time td = 0.1[s]
- Cycle time tc = 2[s]
- Travel distance 1[m]

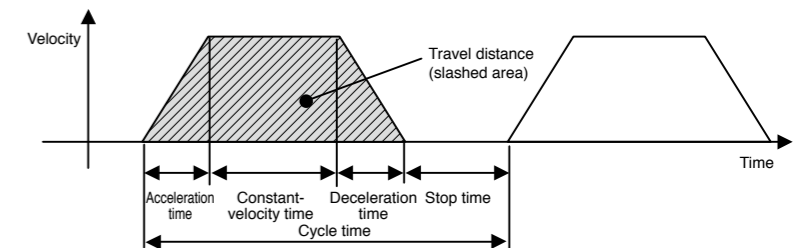

3. Load inertia JL = Jc + JB + JP

$$= Jc + \frac{1}{4}WA \times PD^2 + \frac{1}{8}WP \times PD^2 \times 2$$

$$= 0 + \frac{1}{4} \times 2 \times 0.05^2 + \frac{1}{8} \times 0.5 \times 0.05^2 \times 2 = 0.00156 = 15.6 \times 10^{-4} \text{ [kg}\cdot\text{m}^2\text{]}$$

4. Provisional motor selection

In case of MSME 750 W motor : JM = 0.87 × 10<sup>-4</sup> [kg·m<sup>2</sup>]

5. Calculation of inertia ratio

JL / JM = 15.6 × 10<sup>-4</sup> / 0.87 × 10<sup>-4</sup> Therefore, the inertia ratio is "17.9" (less than "20")

## 6. Calculation of maximum velocity (Vmax)

$$\frac{1}{2} \times \text{Acceleration time} \times V_{\max} + \text{Constant-velocity time} \times V_{\max} + \frac{1}{2} \times \text{Deceleration time} \times V_{\max} = \text{Travel distance}$$

$$\frac{1}{2} \times 0.1 \times V_{\max} + 0.8 \times V_{\max} + \frac{1}{2} \times 0.1 \times V_{\max} = 1$$

$$0.9 \times V_{\max} = 1$$

$$V_{\max} = 1 / 0.9 = 1.111 [\text{m/s}]$$

## 7. Calculation of motor velocity (N [r/min])

A single rotation of pulley :  $\pi \times PD = 0.157 [\text{m}]$

$$N = 1.111 / 0.157 = 7.08 [\text{r/s}]$$

$$= 7.08 \times 60 = 424.8 [\text{r/min}] < 3000 [\text{r/min}] \text{ (Rated velocity of MSME 750 W motor)}$$

## 8. Calculation of torque

Traveling torque  $T_f = \frac{PD}{2\eta} (\mu g W_A + F) = \frac{0.05}{2 \times 0.8} (0.1 \times 9.8 \times 3 + 0)$

$$= 0.061 [\text{N}\cdot\text{m}]$$

Acceleration torque  $T_a = \frac{(J_L + J_M) \times 2\pi N [\text{r/s}]}{\text{Acceleration time} [\text{s}]} + \text{Traveling torque}$

$$= \frac{(15.6 \times 10^{-4} + 0.87 \times 10^{-4}) \times 2\pi \times 7.08}{0.1} + 0.061$$

$$= 0.751 + 0.061 = 0.812 [\text{N}\cdot\text{m}]$$

Deceleration torque  $T_d = \frac{(J_L + J_M) \times 2\pi N [\text{r/s}]}{\text{Deceleration time} [\text{s}]} - \text{Traveling torque}$

$$= \frac{(15.6 \times 10^{-4} + 0.87 \times 10^{-4}) \times 2\pi \times 7.08}{0.1} - 0.061$$

$$= 0.751 - 0.061 = 0.69 [\text{N}\cdot\text{m}]$$

## 9. Verification of maximum torque

Acceleration torque  $T_a = 0.812 [\text{N}\cdot\text{m}] < 7.1 [\text{N}\cdot\text{m}]$  (Maximum torque of MSME 750 W motor)

## 10. Verification of effective torque

$$T_{\text{rms}} = \sqrt{\frac{T_a^2 \times t_a + T_f^2 \times t_b + T_d^2 \times t_d}{t_c}}$$

$$= \sqrt{\frac{0.812^2 \times 0.1 + 0.061^2 \times 0.8 + 0.69^2 \times 0.1}{2}}$$

$$= 0.241 [\text{N}\cdot\text{m}] < 2.4 [\text{N}\cdot\text{m}] \text{ (Rated torque of MSME 750 W motor)}$$

11. Judging from the above calculation result, selection of MSME 750W motor is acceptable.

## Request for motor selection I : Ball screw drive

### 1. Driven mechanism and running data

- 1) Travel distance of the work load per one cycle  mm
- 2) Cycle time  s  
(Fill in items 3) and 4) if required.)
- 3) Acceleration time  s
- 4) Deceleration time  s
- 5) Stopping time  s
- 6) Max. velocity  mm/s
- 7) External force  N
- 8) Positioning accuracy of the work load  mm
- 9) Total weight of the work load and the table  kg
- 10) Power supply voltage
- 11) Diameter of the ball screw
- 12) Total length of the ball
- 13) Lead of the ball screw

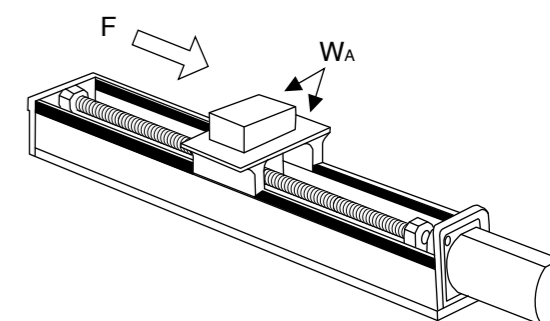
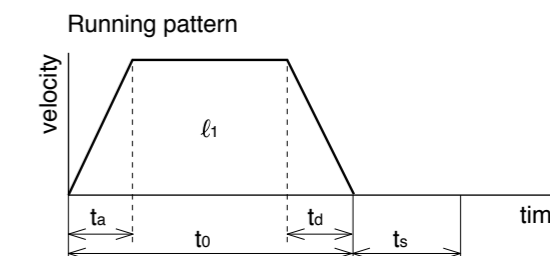

14) Traveling direction (horizontal, vertical etc.)

### 2. Other data (Fill the details on specific mechanism and its configurations in the following blank.)

Company name : \_\_\_\_\_

Department/Section : \_\_\_\_\_

Name : \_\_\_\_\_

Address : \_\_\_\_\_

Tel : \_\_\_\_\_

Fax : \_\_\_\_\_

E-mail address: \_\_\_\_\_

# Request Sheet for Motor Selection

## Request for motor selection II : Timing pulley + Ball screw drive

### 1. Driven mechanism and running data

1) Travel distance of the work load per one cycle	$l_1$ : mm	15) Diameter of the pulley	Motor side $D_1$ : mm	Ball screw side $D_2$ : mm
2) Cycle time	$t_o$ : s	16) Weight of the pulley	$W_1$ : kg	$W_2$ : kg
(Fill in items 3) and 4) if required.)		(or item 17) and 18))		
3) Acceleration time	$t_a$ : s	17) Width of the pulley	$L_1$ : mm	
4) Deceleration time	$t_d$ : s	18) Material of the pulley		
5) Stopping time	$t_s$ : s	19) Weight of the belt	$W_M$ : kg	
6) Max. velocity	$V$ : mm/s			
7) External force	$F$ : N			
8) Positioning accuracy of the work load	$\pm$ mm			
9) Total weight of the work load and the table	$W_A$ : kg			
10) Power supply voltage	V			
11) Diameter of the ball screw	mm			
12) Total length of the ball screw	mm			
13) Lead of the ball screw	mm			
14) Traveling direction (horizontal, vertical etc.)				

### 2. Other data (Fill the details on specific mechanism and its configurations in the following blank.)

Company name :
Department/Section :
Name :
Address :
Tel :
Fax :
E-mail address:

# Request Sheet for Motor Selection

## Request for motor selection III : Belt drive

### 1. Driven mechanism and running data

1) Travel distance of the work load per one cycle	$l_1$ : mm		
2) Cycle time	$t_o$ : s		
3) Acceleration time	$t_a$ : s		
4) Deceleration time	$t_d$ : s		
(Fill in items 3) and 4) if required.)		(or item 14) and 15))	
5) Stopping time	$t_s$ : s	14) Width of the pulley	$L_1$ : mm
6) Max. velocity	$V$ : mm/s	15) Material of the pulley	
7) External force	$F$ : N	16) Traveling direction (horizontal, vertical etc.)	
8) Positioning accuracy of the work load	$\pm$ mm		
9) Total weight of the work load	$W_A$ : kg		
10) Power supply voltage	V		
11) Weight of the belt	$W_M$ : kg		
12) Diameter of the driving pulley	$D_1$ : mm		
13) Total weight of the pulley	$W_1$ : kg		

### 2. Other data (Fill the details on specific mechanism and its configurations in the following blank.)

Company name :
Department/Section :
Name :
Address :
Tel :
Fax :
E-mail address:



# Request Sheet for Motor Selection

## Request for motor selection IV : Timing pulley + Belt drive

### 1. Driven mechanism and running data

1) Travel distance of the work load per one cycle  mm

2) Cycle time  s

(Fill in items 3) and 4) if required.)

3) Acceleration time  s

4) Deceleration time  s

5) Stopping time  s

6) Max. velocity  mm/s

7) External force  N

8) Positioning accuracy of the work load  mm

9) Total weight of the work load and the table  kg

10) Power supply voltage

11) Weight of motor side belt  kg

	Motor side	Belt side
12) Diameter of the pulley	<input type="text" value="D&lt;sub&gt;1&lt;/sub&gt;"/> mm	<input type="text" value="D&lt;sub&gt;2&lt;/sub&gt;"/> mm
13) Weight of the pulley	<input type="text" value="W&lt;sub&gt;1&lt;/sub&gt;"/> kg	<input type="text" value="W&lt;sub&gt;2&lt;/sub&gt;"/> kg

(or item 14) and 15))

14) Width of the belt  mm

15) Material of the pulley

	Motor side	Belt side
16) Diameter of the pulley	<input type="text" value="D&lt;sub&gt;3&lt;/sub&gt;"/> mm	<input type="text" value="D&lt;sub&gt;4&lt;/sub&gt;"/> mm
17) Weight of the pulley	<input type="text" value="W&lt;sub&gt;3&lt;/sub&gt;"/> kg	<input type="text" value="W&lt;sub&gt;4&lt;/sub&gt;"/> kg

18) Width of the pulley  mm

(or item 18) and 19))

19) Material of the pulley

20) Weight of the belt  kg

21) Traveling direction (horizontal, vertical etc.)

Running pattern

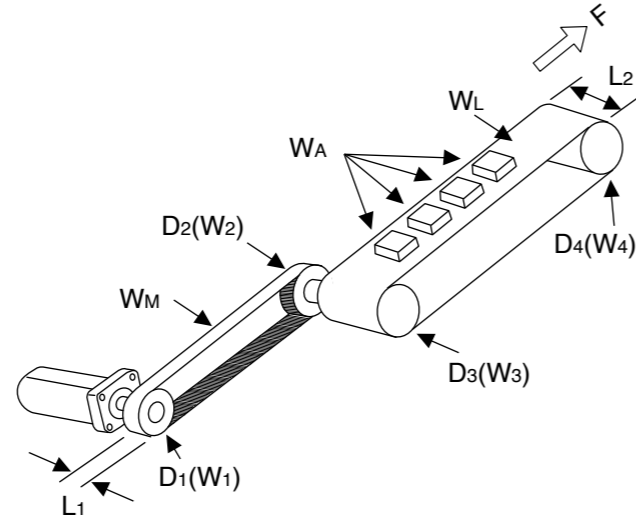
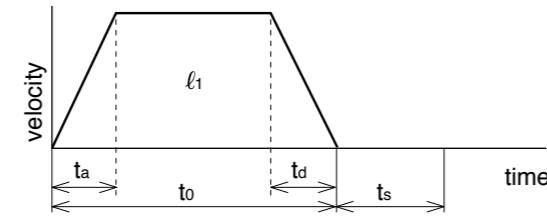

### 2. Other data (Fill the details on specific mechanism and its configurations in the following blank.)

Company name : \_\_\_\_\_

Department/Section : \_\_\_\_\_

Name : \_\_\_\_\_

Address : \_\_\_\_\_

Tel : \_\_\_\_\_

Fax : \_\_\_\_\_

E-mail address: \_\_\_\_\_

# Request Sheet for Motor Selection

## Request for motor selection V : Turntable drive

### 1. Driven mechanism and running data

1) Travel distance of the work load per one cycle  deg

2) Cycle time  s

(Fill in items 3) and 4) if required.)

3) Acceleration time  s

4) Deceleration time  s

5) Stopping time  s

6) Max. rotational speed of the table  deg/s

(or)  r/s

7) Positioning accuracy of the work load  deg

8) Weight of one work load  kg

9) Driving radius of the center of gravity of the work  mm

10) Diameter of the table  mm

11) Mass of the table  kg

12) Diameter of the table support  mm

13) Power supply voltage

	Prism	Cylinder
14) Dimensions of the work load	<input type="text" value="a"/> mm	<input type="text" value="a"/> mm
	<input type="text" value="b"/> mm	<input type="text" value="b"/> mm
	<input type="text" value="c"/> mm	<input type="text" value="c"/> mm

15) Number of work loads

Running pattern

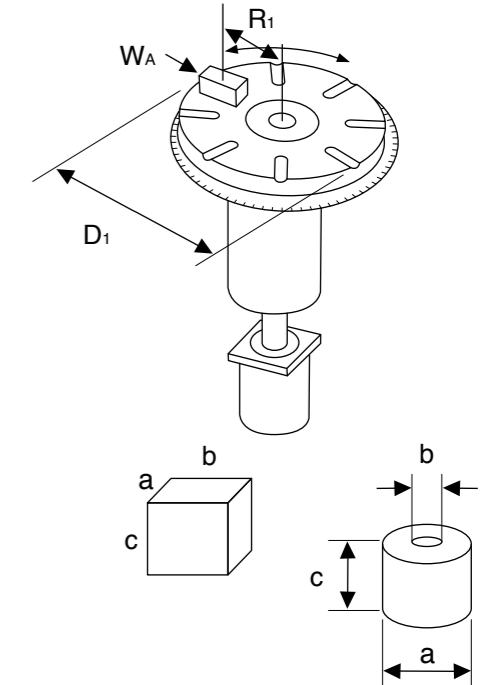
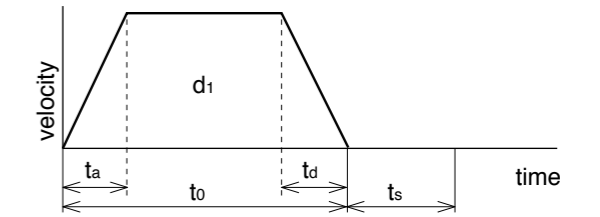

### 2. Other data (Fill the details on specific mechanism and its configurations in the following blank.)

Company name : \_\_\_\_\_

Department/Section : \_\_\_\_\_

Name : \_\_\_\_\_

Address : \_\_\_\_\_

Tel : \_\_\_\_\_

Fax : \_\_\_\_\_

E-mail address: \_\_\_\_\_

# Request Sheet for Motor Selection

## Request for motor selection VI : Timing pulley + Turntable drive

### 1. Driven mechanism and running data

1) Travel distance of the work load per one cycle	d <sub>1</sub> : <input type="text"/> deg	16) Diameter of the pulley	Motor side D <sub>2</sub> : <input type="text"/> mm	Turntable side D <sub>3</sub> : <input type="text"/> mm			
2) Cycle time	t <sub>0</sub> : <input type="text"/> s	17) Weight of the pulley	W <sub>2</sub> : <input type="text"/> kg	W <sub>3</sub> : <input type="text"/> kg			
(Fill in items 3) and 4) if required.)		(or item 18) and 19))					
3) Acceleration time	t <sub>a</sub> : <input type="text"/> s	18) Width of the pulley	L <sub>1</sub> : <input type="text"/> mm				
4) Deceleration time	t <sub>d</sub> : <input type="text"/> s	19) Material of the pulley	<input type="text"/>				
5) Stopping time	t <sub>s</sub> : <input type="text"/> s	20) Weight of the belt	W <sub>M</sub> : <input type="text"/> kg				
6) Max. rotational speed of the table	v: <input type="text"/> deg/s						
(or)	V: <input type="text"/> r/s						
7) Positioning accuracy of the work load	± <input type="text"/> deg						
8) Weight of one work load	W <sub>A</sub> : <input type="text"/> kg						
9) Driving radius of the center of gravity of the work	R <sub>1</sub> : <input type="text"/> mm						
10) Diameter of the table	D <sub>1</sub> : <input type="text"/> mm						
11) Mass of the table	W <sub>1</sub> : <input type="text"/> kg						
12) Diameter of the table support	T <sub>1</sub> : <input type="text"/> mm						
13) Power supply voltage	<input type="text"/> V						
14) Dimension of the work load	(Prism)				(Cylinder)		
	a: <input type="text"/> mm				a: <input type="text"/> mm		
	b: <input type="text"/> mm				b: <input type="text"/> mm		
	c: <input type="text"/> mm	c: <input type="text"/> mm					
15) Number of work loads	<input type="text"/> pcs						

### 2. Other data (Fill the details on specific mechanism and its configurations in the following blank.)

	Company name :
	Department/Section :
	Name :
	Address :
	Tel :
	Fax :
E-mail address:	

# Request Sheet for Motor Selection

## Request for motor selection VII : Roller feed drive

### 1. Driven mechanism and running data

1) Travel distance of the work load per one cycle	l <sub>1</sub> : <input type="text"/> mm		
2) Cycle time	t <sub>0</sub> : <input type="text"/> s		
(Fill in items 3) and 4) if required.)			
3) Acceleration time	t <sub>a</sub> : <input type="text"/> s		
4) Deceleration time	t <sub>d</sub> : <input type="text"/> s		
5) Stopping time	t <sub>s</sub> : <input type="text"/> s		
6) Max. velocity	v: <input type="text"/> mm/s		
7) External pulling force	F: <input type="text"/> N		
8) Positioning accuracy of the work load	± <input type="text"/> mm		
9) Number of rollers	<input type="text"/> pcs		
10) Power supply voltage	<input type="text"/> V		
11) Diameter of the roller	D <sub>1</sub> : <input type="text"/> mm		
12) Mass of the roller	W <sub>1</sub> : <input type="text"/> kg		
		13) Width of the roller	L <sub>1</sub> : <input type="text"/> mm
		14) Material of the roller	<input type="text"/>

### 2. Other data (Fill the details on specific mechanism and its configurations in the following blank.)

	Company name :
	Department/Section :
	Name :
	Address :
	Tel :
	Fax :
E-mail address:	

# Request Sheet for Motor Selection

## Request for motor selection VIII : Driving with Rack & Pinion

### 1. Driven mechanism and running data

- 1) Travel distance of the work load per one cycle  $l_1$ : mm
- 2) Cycle time to: s
- (Fill in items 3) and 4) if required.)
- 3) Acceleration time  $t_a$ : s
- 4) Deceleration time  $t_d$ : s
- 5) Stopping time  $t_s$ : s
- 6) Max. velocity  $V$ : mm/s
- 7) External force  $F$ : N
- 8) Positioning accuracy of the work load  $\pm$ : mm
- 9) Total weight of the work load  $W_A$ : kg
- 10) Power supply voltage  $V$ : V
- 11) Diameter of the pinion  $D_3$ : mm
- 12) Mass of the pinion  $W_3$ : kg
- 13) Traveling direction (horizontal, vertical, etc.)

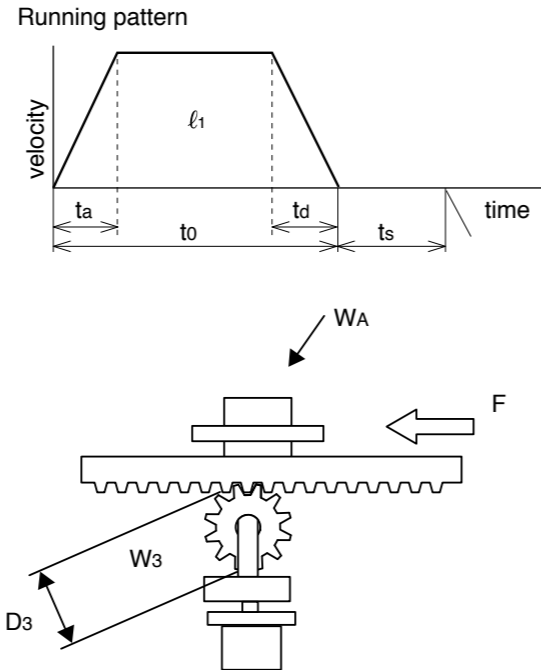

### 2. Other data (Fill the details on specific mechanism and its configurations in the following blank.)

Company name : \_\_\_\_\_

Department/Section : \_\_\_\_\_

Name : \_\_\_\_\_

Address : \_\_\_\_\_

Tel : \_\_\_\_\_

Fax : \_\_\_\_\_

E-mail address: \_\_\_\_\_

# Connection Between Driver and Controller

# A5 Family Connection Between Driver and Controller

## FP7-AFP7PP02T/L(2-axes) AFP7PP04T/L(4-axes) Connection with the Panasonic devices SUNX.

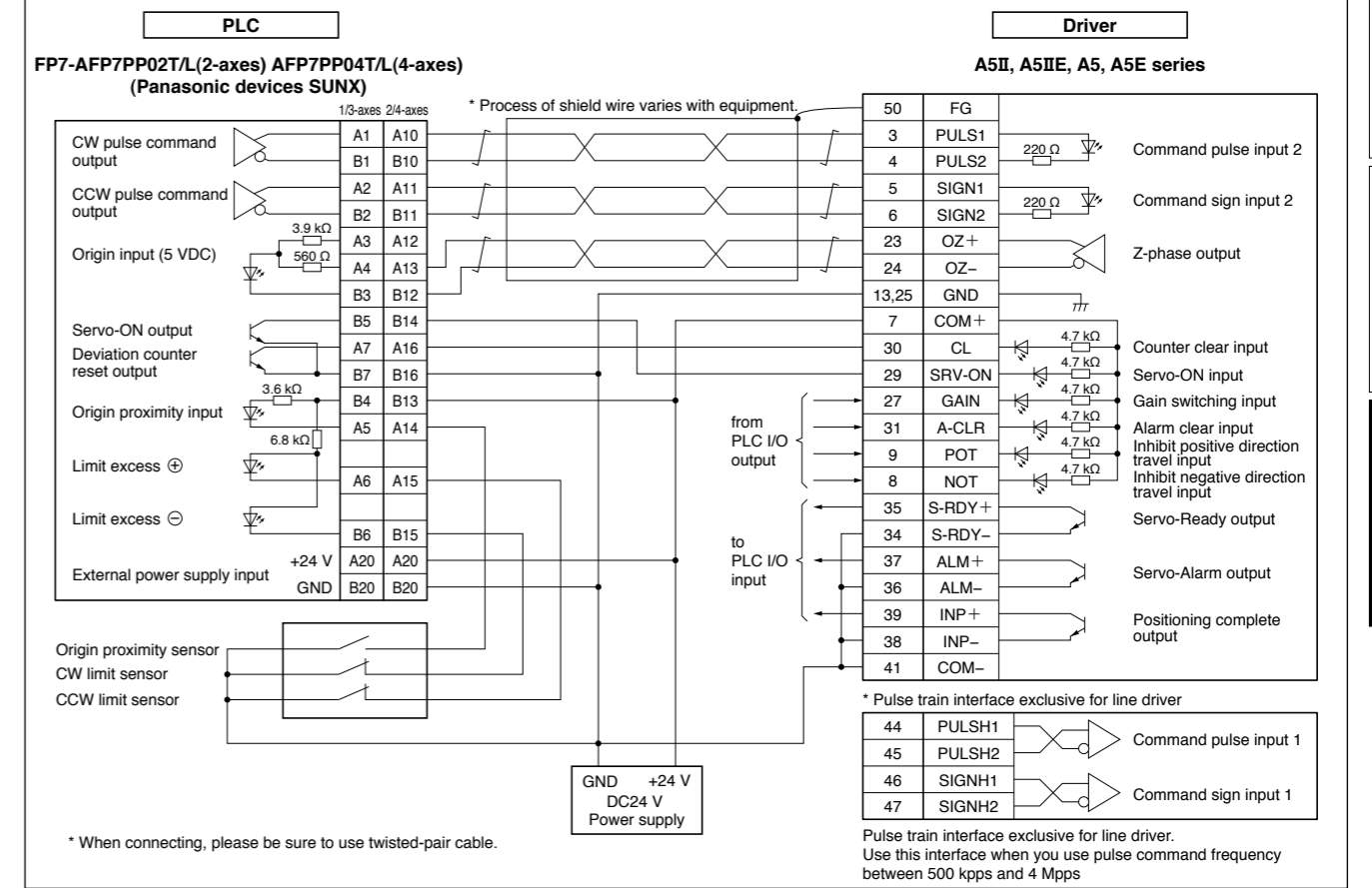

\* When connecting, please be sure to use twisted-pair cable.

## FPG-PP12 AFPG432 Connection with the Panasonic devices SUNX.

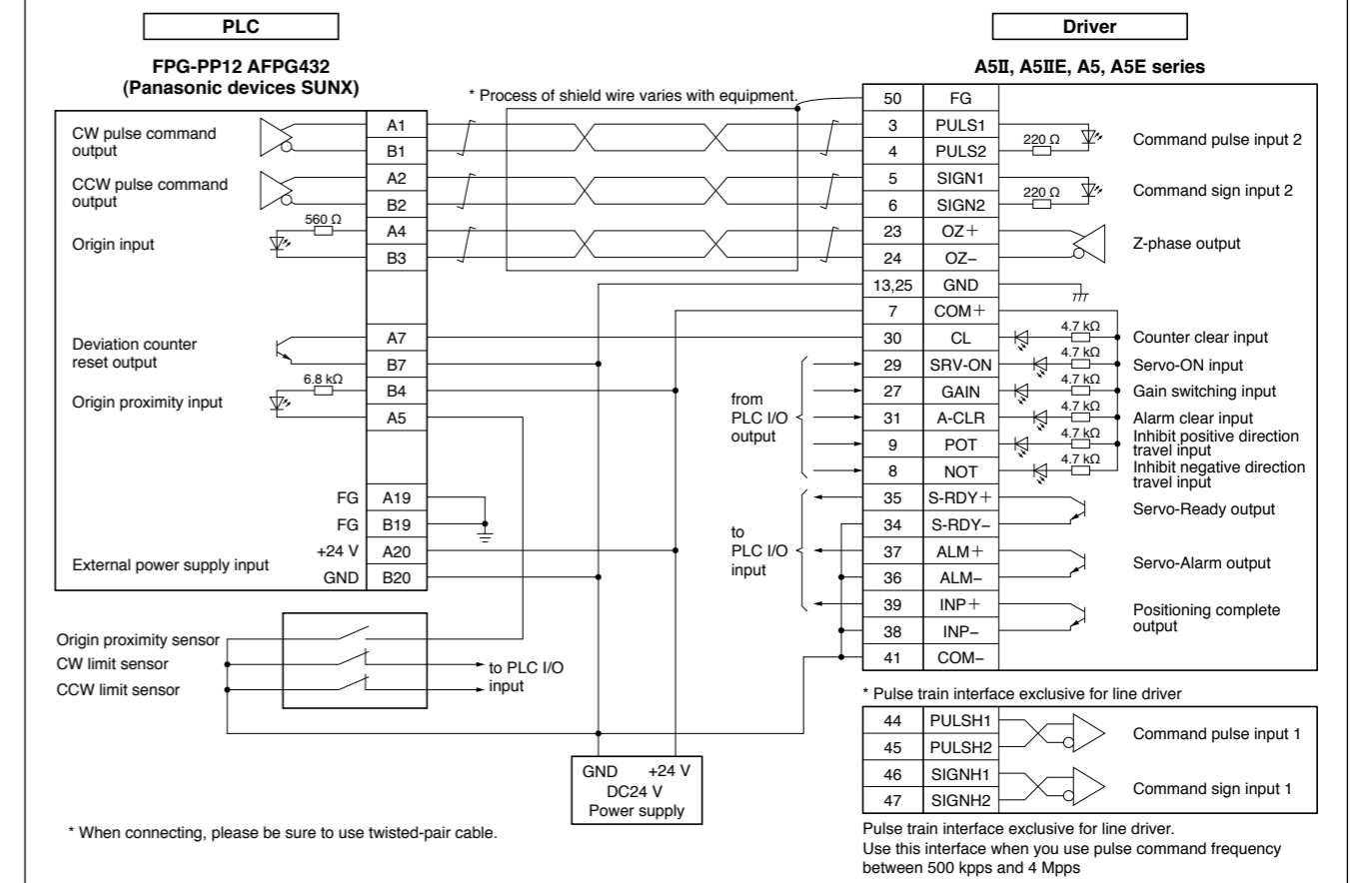

\* When connecting, please be sure to use twisted-pair cable.

FP2-PP2 AFP2430 Connection with the Panasonic devices SUNX.

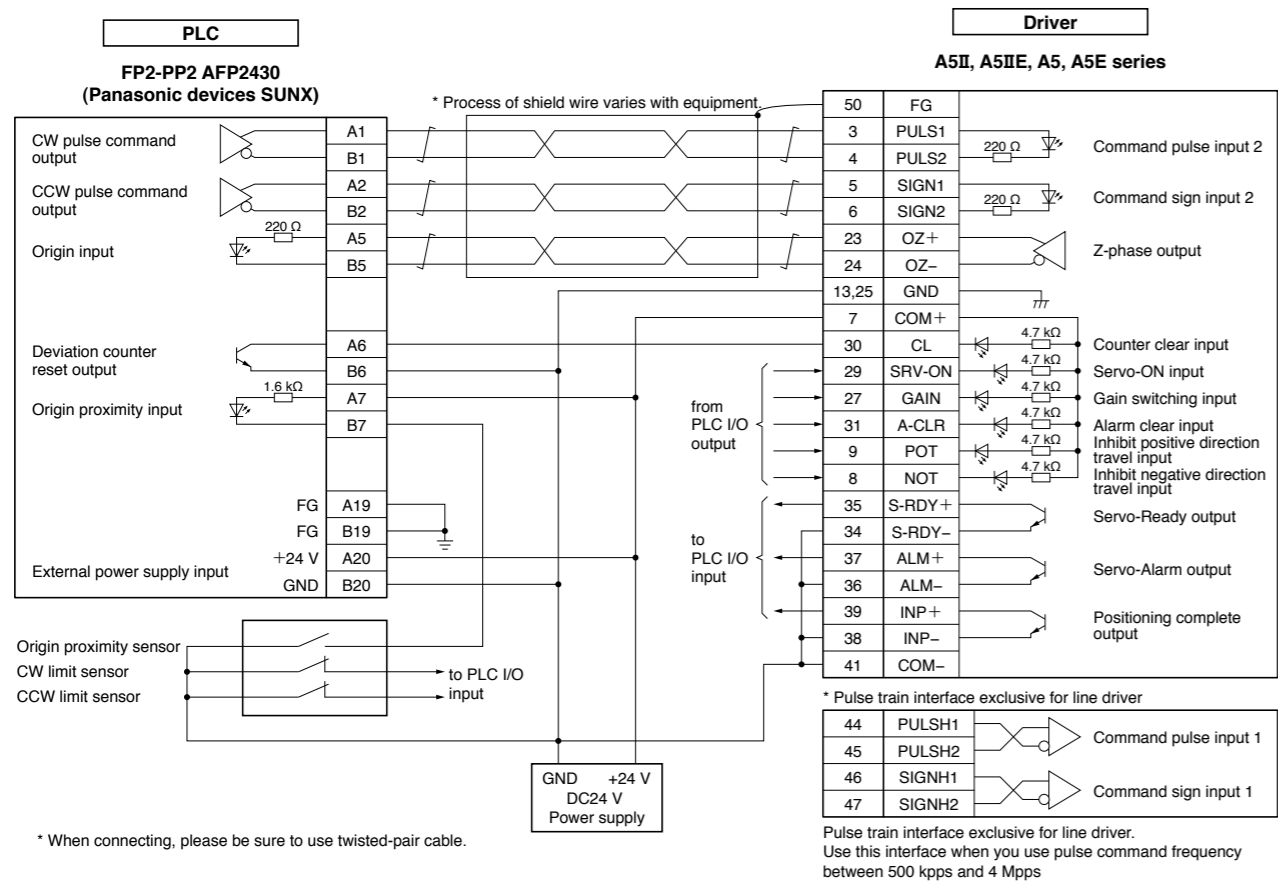

F3YP22-0P/F3YP24-0P/F3YP28-0P Connection with the Yokogawa Electric Corp.

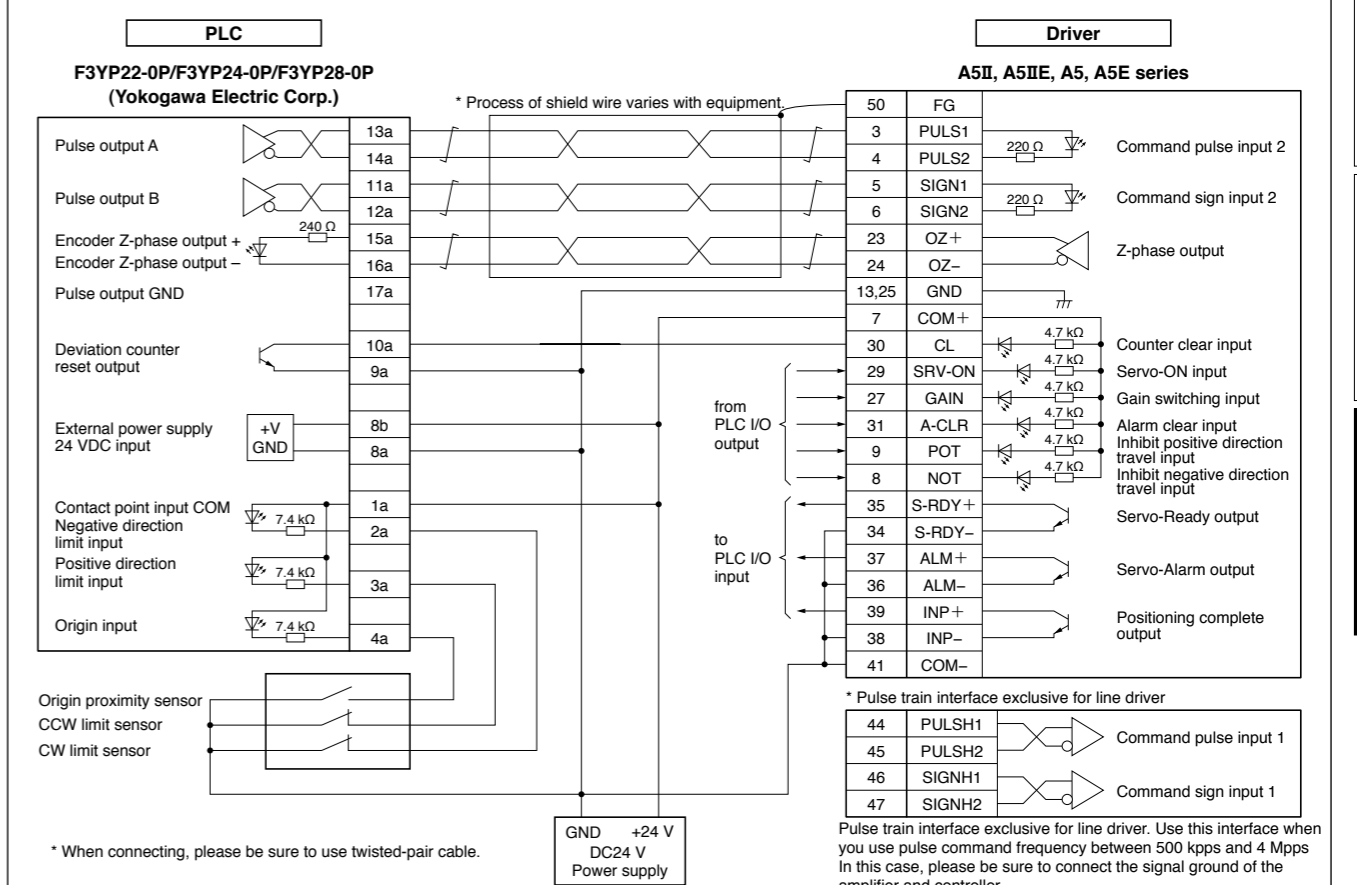

FPG-C32T Connection with the Panasonic devices SUNX.

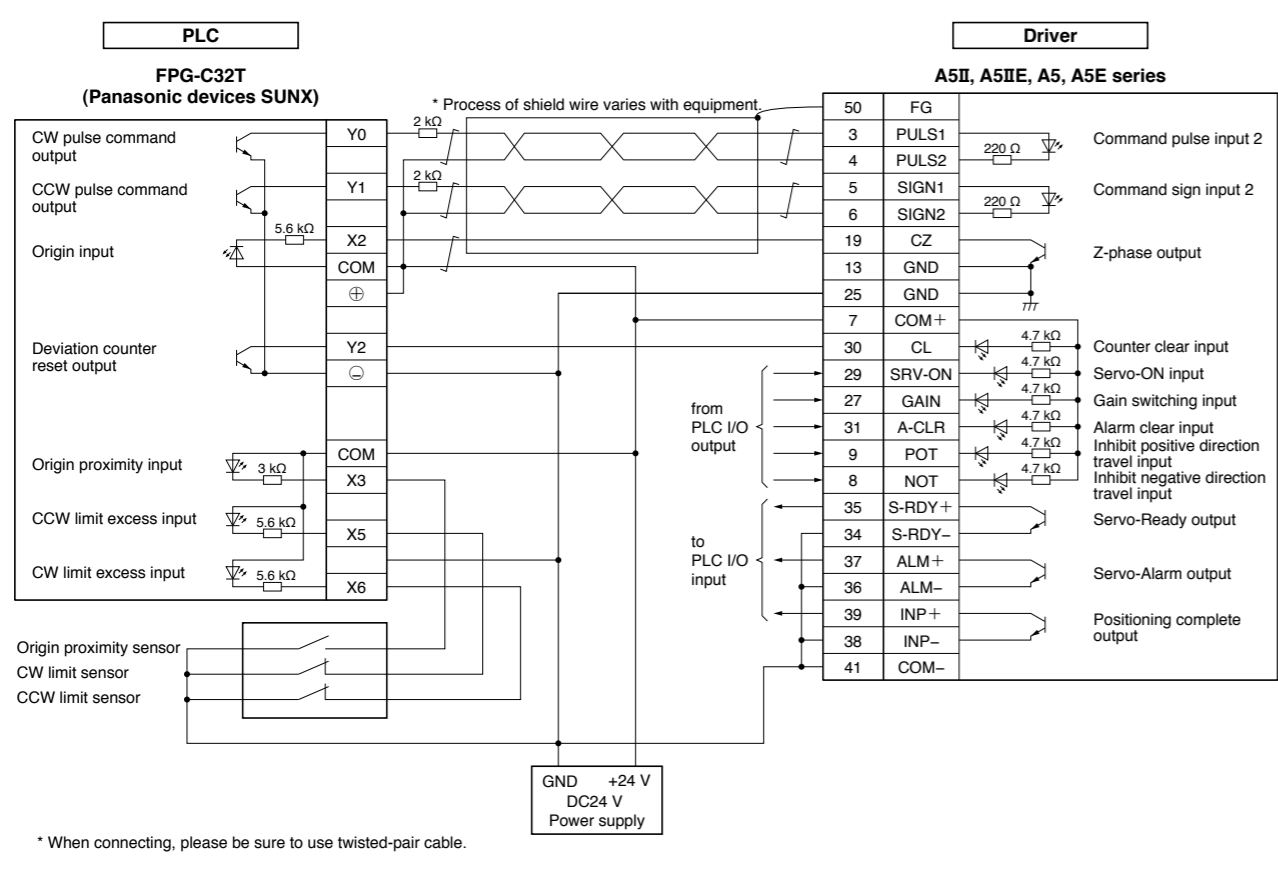

F3NC32-ON/F3NC34-ON Connection with the Yokogawa Electric Corp.

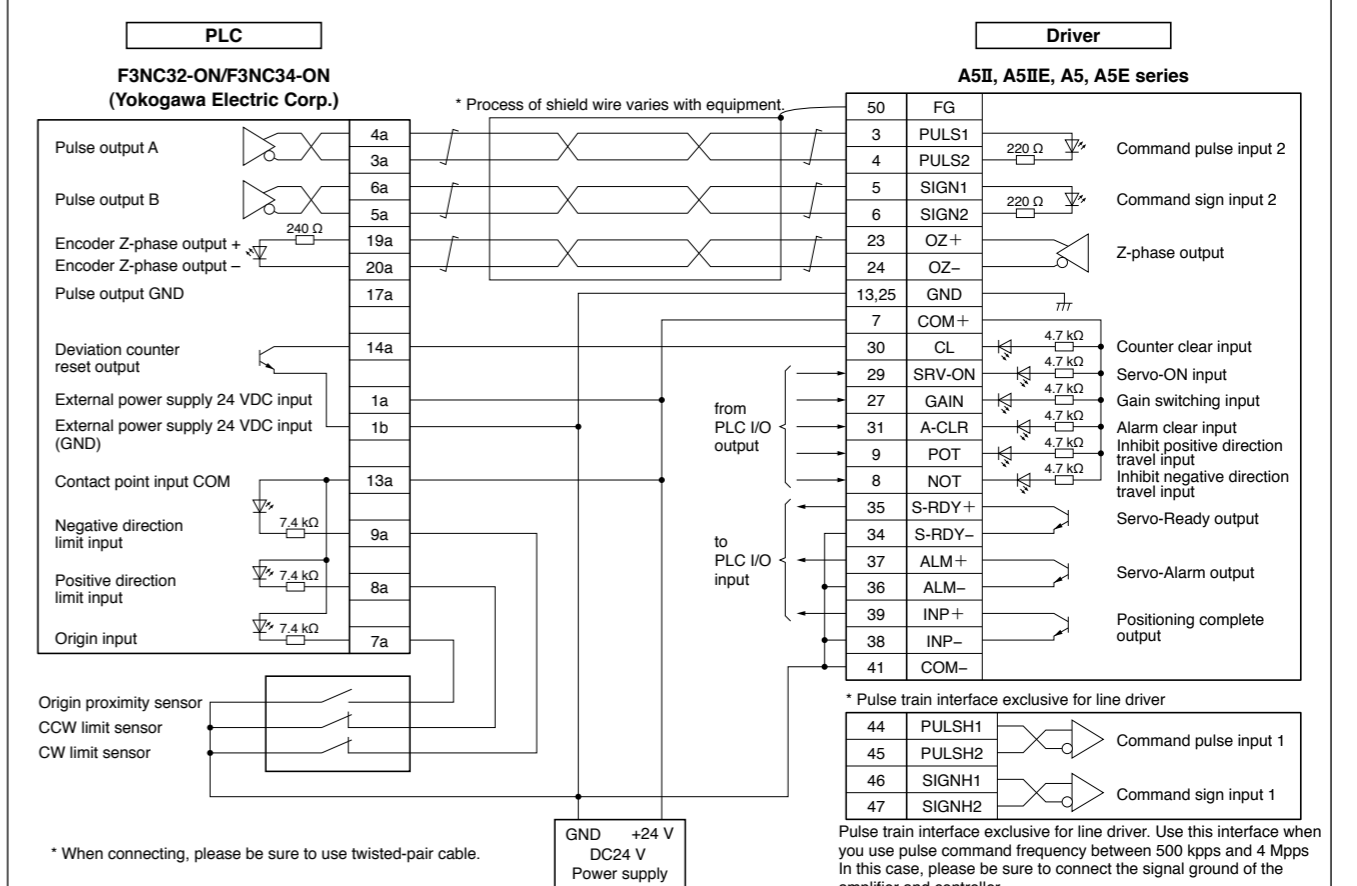

CJ1W-NC113 Connection with the Omron Corp.

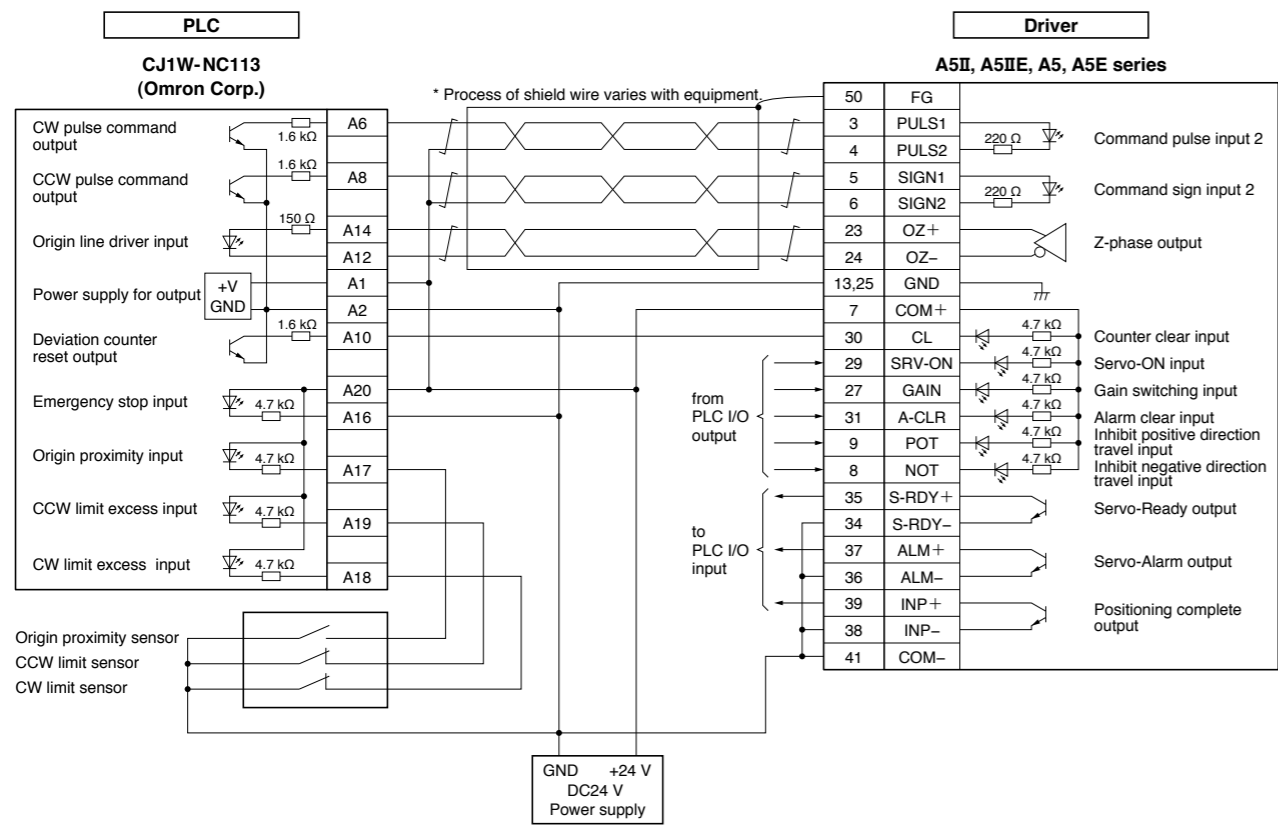

QD75D1 Connection with the Mitsubishi Electric Corp.

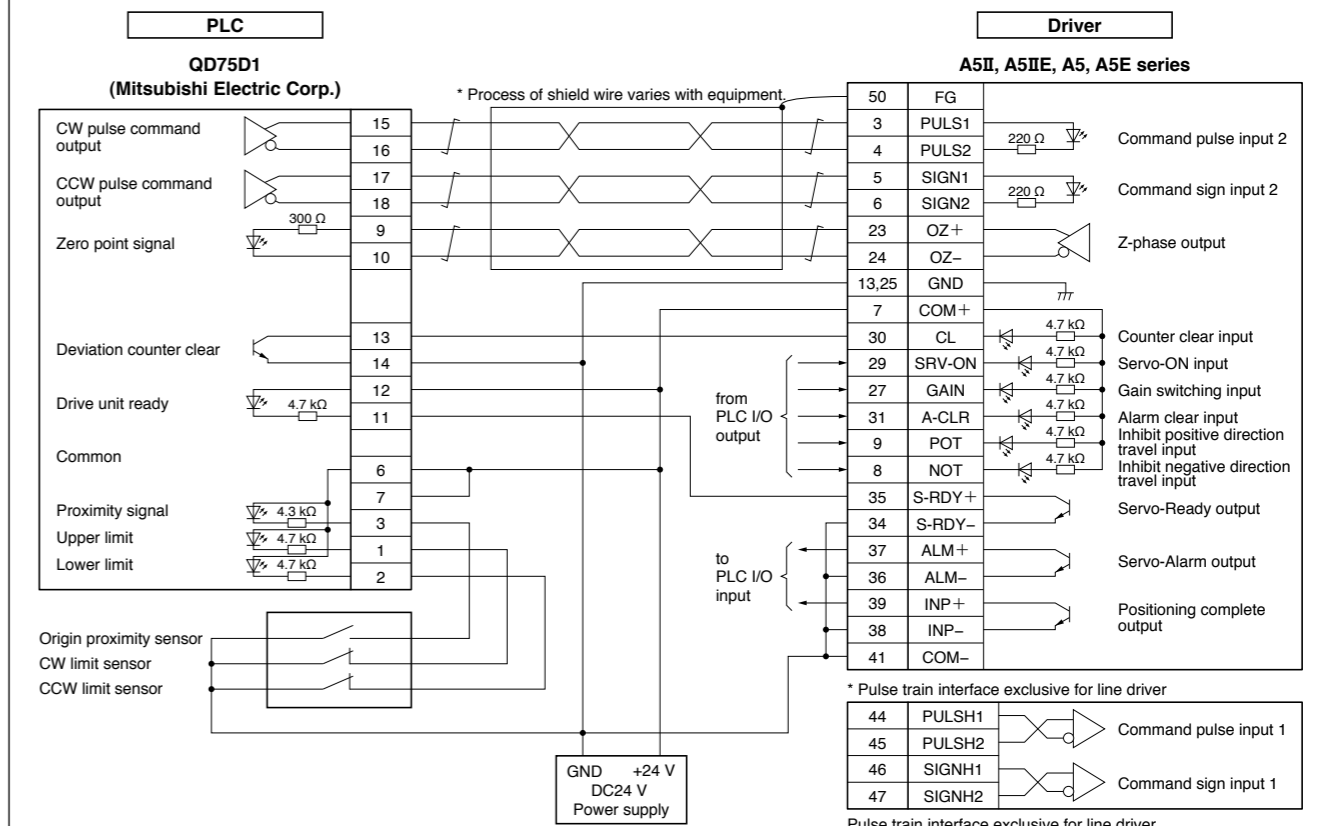

CJ1W-NC133 Connection with the Omron Corp.

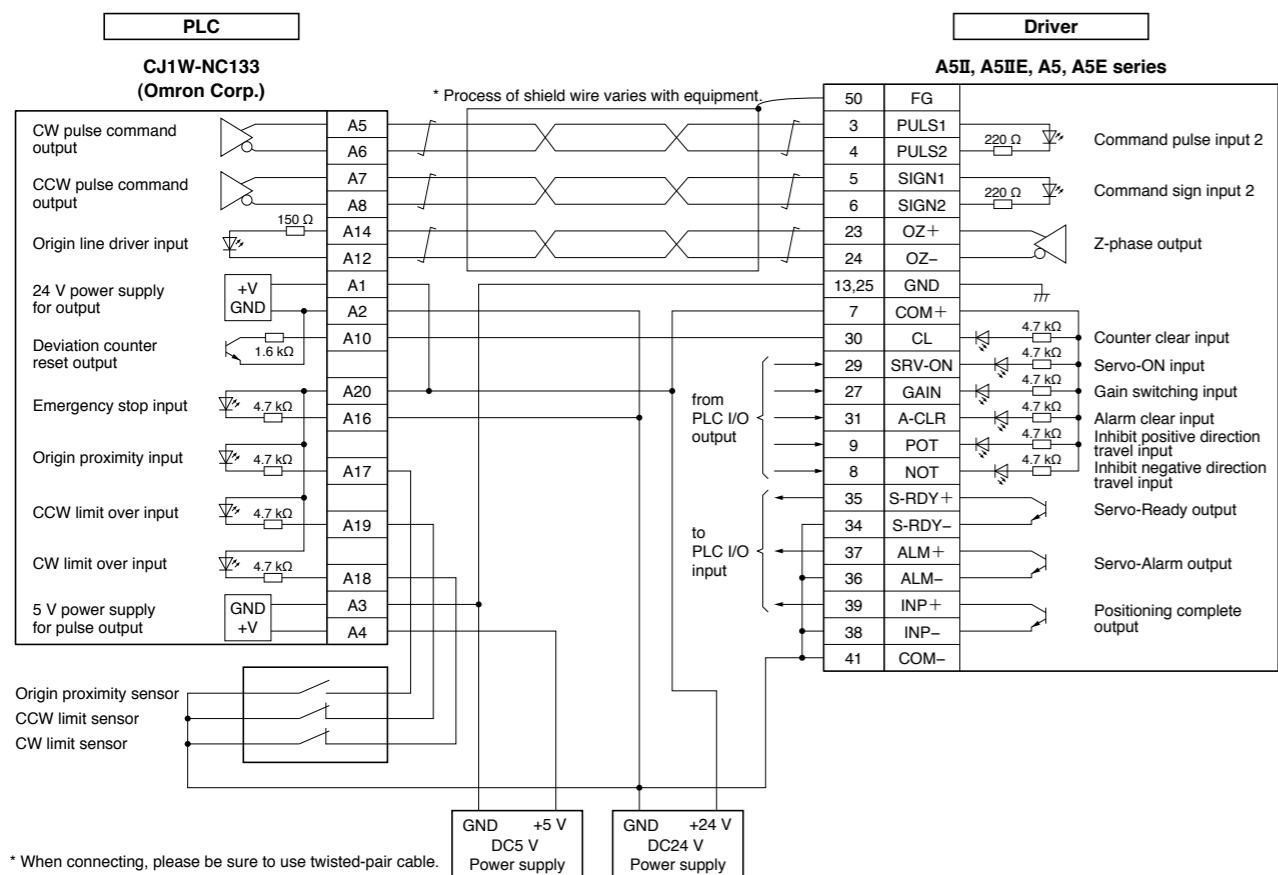

KV-5000/3000 Connection with the KEYENCE Corp.

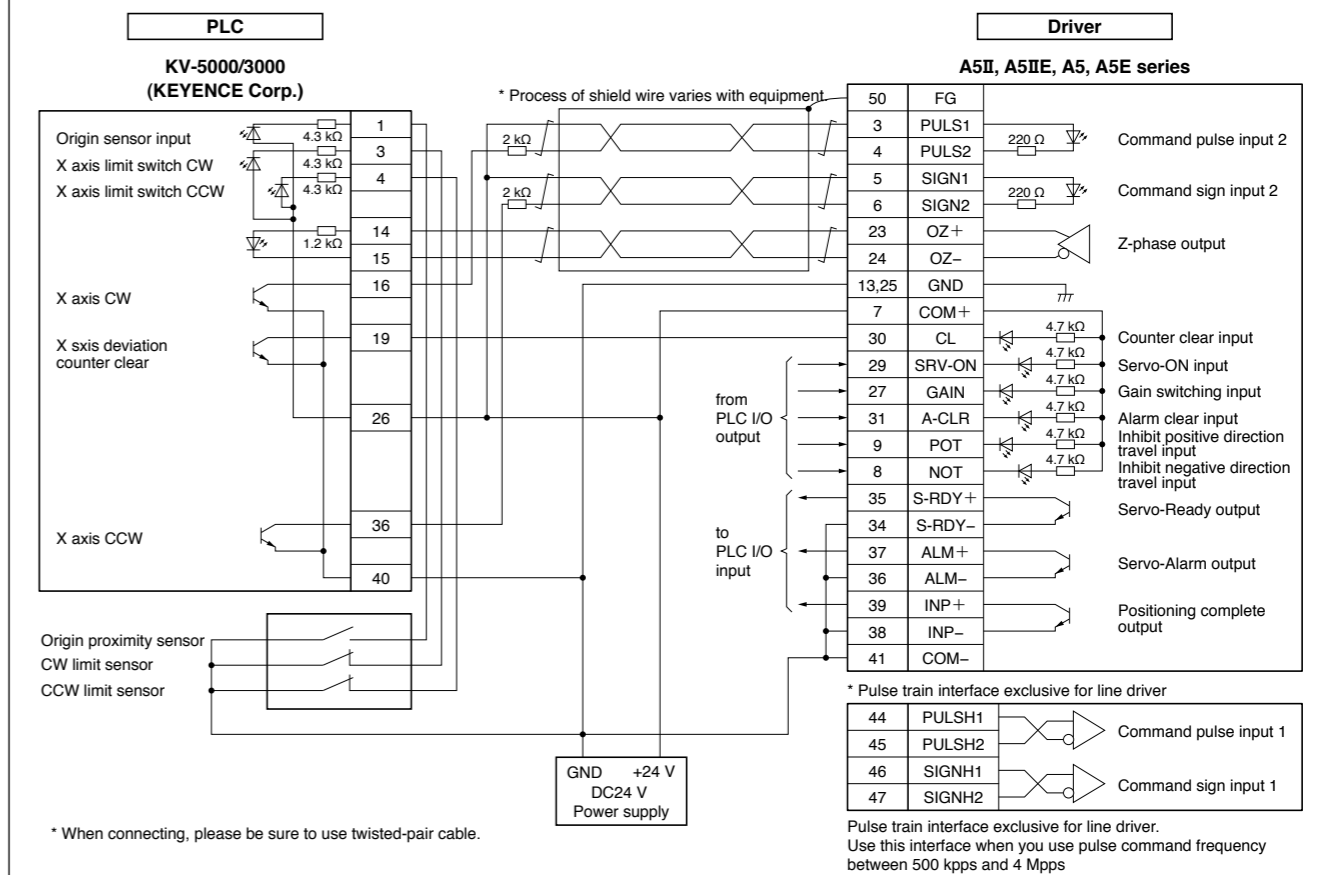

# Replacing Old Model Servo Driver with MINAS A5II, A5 series

For easier replacement of old driver (MINAS X/XX/V series) with A5II, A5 series, use the interface conversion connector.

<36-pin → 50-pin>

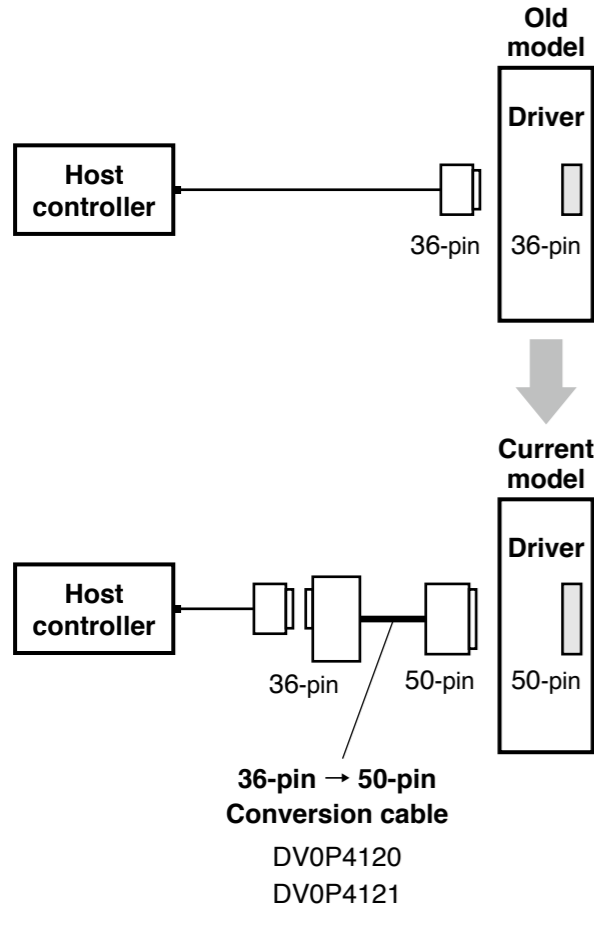

<50-pin → 50-pin>

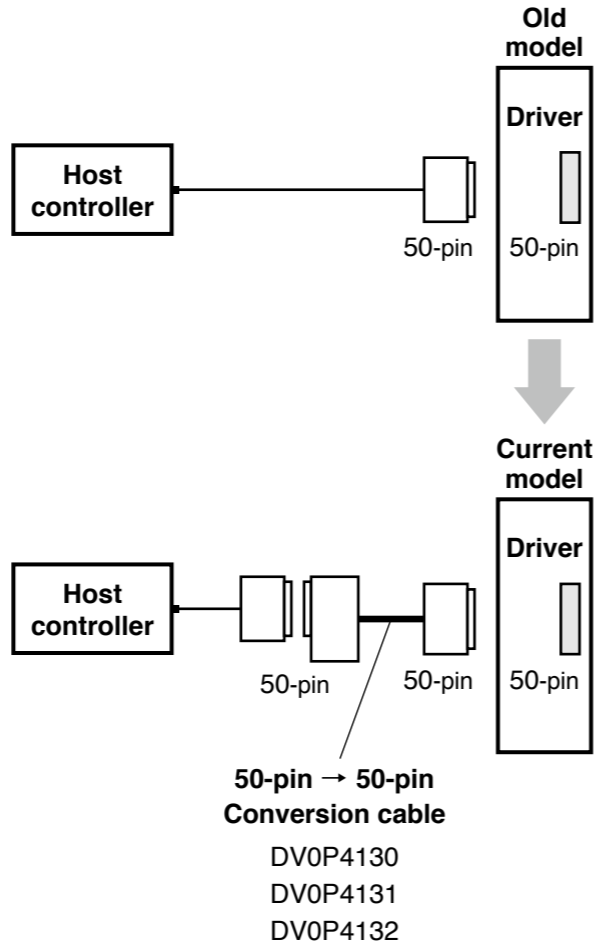

When selecting the cable, refer to the table below because the part number of the cable is specific to the control mode of the old model.

Old model	Control mode	Conversion cable part No.	Conversion wiring table
X series XX series (36-pin)	Position/velocity control	DV0P4120	P.280
	Torque control	DV0P4121	
V series (50-pin)	Position control	DV0P4130	P.281
	Velocity control	DV0P4131	
	Torque control	DV0P4132	P.282

\* For external dimensions, refer to P.197.

## Conversion Wiring Table

Pin No. on Old Model	DV0P4120			DV0P4121		
	Pin No. on Current Model	Signal Name	Symbol	Pin No. on Current Model	Signal Name	Symbol
1	23	Z-phase output	OZ+	23	Z-phase output	OZ+
2	24	Z-phase output	OZ-	24	Z-phase output	OZ-
3	13	Signal ground	GND	13	Signal ground	GND
4	19	Z-phase output	CZ	19	Z-phase output	CZ
5	4	Command pulse input 2	PULS2	4	Command pulse input 2	PULS2
6	3	Command pulse input 2	PULS1	3	Command pulse input 2	PULS1
7	6	Command pulse sign input 2	SIGN2	6	Command pulse sign input 2	SIGN2
8	5	Command pulse sign input 2	SIGN1	5	Command pulse sign input 2	SIGN1
9	33	Command pulse inhibition input	INH	33	Command pulse inhibition input	INH
10	26	Speed zero clamp input	ZEROSPD	26	Speed zero clamp input	ZEROSPD
11	7	Power supply for control signal (+)	COM+	7	Power supply for control signal (+)	COM+
12	29	Servo-ON input	SRV-ON	29	Servo-ON input	SRV-ON
13	30	Deviation counter clear input	CL	30	Deviation counter clear input	CL
14	14	Speed command input	SPR	NC		
15	15	Signal ground	GND	15	Signal ground	GND
16	43	Speed monitor output	SP	43	Speed monitor output	SP
17	25	Signal ground	GND	25	Signal ground	GND
18	50	Frame ground	FG	50	Frame ground	FG
19	21	A-phase output	OA+	21	A-phase output	OA+
20	22	A-phase output	OA-	22	A-phase output	OA-
21	48	B-phase output	OB+	48	B-phase output	OB+
22	49	B-phase output	OB-	49	B-phase output	OB-
23	NC			NC		
24	NC			NC		
25	39	Positioning complete output Speed arrival output	COIN+ AT-SPEED+	39	Positioning complete output Speed arrival output	COIN+ AT-SPEED+
26	37	Servo-Alarm output	ALM+	37	Servo-Alarm output	ALM+
27	35	Servo-Ready output	S-RDY+	35	Servo-Ready output	S-RDY+
28	34	Positioning complete output (-) Speed arrival output (-)	COIN- AT-SPEED-	34	Positioning complete output (-) Speed arrival output (-)	COIN- AT-SPEED-
	36	Servo-Alarm output (-)	ALM-	36	Servo-Alarm output (-)	ALM-
	38	Servo-Ready output (-)	S-RDY-	38	Servo-Ready output (-)	S-RDY-
	41	Power supply for control signal (-)	COM-	41	Power supply for control signal (-)	COM-
29	8	CW over-travel inhibit input	CWL	8	CW over-travel inhibit input	CWL
30	9	CCW over-travel inhibit input	CCWL	9	CCW over-travel inhibit input	CCWL
31	31	Alarm clear input	A-CLR	31	Alarm clear input	A-CLR
32	32	Control mode switching input	C-MODE	32	Control mode switching input	C-MODE
33	18	CW direction torque limit input	CWTL	18	CW direction torque limit input	CWTL
34	16	CCW direction torque limit input	CCWTL	14	Torque command input	TRQR
35	17	Signal ground	GND	17	Signal ground	GND
36	42	Torque monitor output	IM	42	Torque monitor output	IM

\* "NC" is no connect.

Pin No. on Old Model	DV0P4130			DV0P4131		
	Pin No. on Current Model	Signal Name	Symbol	Pin No. on Current Model	Signal Name	Symbol
1	8	CW over-travel inhibit input	CWL	8	CW over-travel inhibit input	CWL
2	9	CCW over-travel inhibit input	CCWL	9	CCW over-travel inhibit input	CCWL
3	3	Command pulse input 2	PULS1	NC		
4	4	Command pulse input 2	PULS2	NC		
5	5	Command pulse sign input 2	SIGN1	NC		
6	6	Command pulse sign input 2	SIGN2	NC		
7	7	Power supply for control signal (+)	COM+	7	Power supply for control signal (+)	COM+
8	NC			NC		
9	NC			NC		
10	NC			NC		
11	11	External brake release signal	BRK-OFF+	11	External brake release signal	BRK-OFF+
12	12	Zero-speed detection output signal	ZSP	12	Zero-speed detection output signal	ZSP
13	13	Torque in-limit signal output	TLC	13	Torque in-limit signal output	TLC
14	NC			14	Speed command input	SPR
15	15	Signal ground	GND	15	Signal ground	GND
16	16	CCW direction torque limit input	CCWTL	16	CCW direction torque limit input	CCWTL
17	17	Signal ground	GND	17	Signal ground	GND
18	18	CW direction torque limit input	CWTL	18	CW direction torque limit input	CWTL
19	19	Z-phase output	CZ	19	Z-phase output	CZ
20	NC			NC		
21	21	A-phase output	OA+	21	A-phase output	OA+
22	22	A-phase output	OA-	22	A-phase output	OA-
23	23	Z-phase output	OZ+	23	Z-phase output	OZ+
24	24	Z-phase output	OZ-	24	Z-phase output	OZ-
25	50	Frame ground	FG	50	Frame ground	FG
26	26	Speed zero clamp input	ZEROSPD	26	Speed zero clamp input	ZEROSPD
27	27	Gain switching input	GAIN	27	Gain switching input	GAIN
28	NC			33	Selection 1 input of internal command speed	INTSPD1
29	29	Servo-ON input	SRV-ON	29	Servo-ON input	SRV-ON
30	30	Deviation counter clear input	CL	NC		
31	31	Alarm clear input	A-CLR	31	Alarm clear input	A-CLR
32	32	Control mode switching input	C-MODE	32	Control mode switching input	C-MODE
33	33	Command pulse inhibition input	INH	NC		
34	NC			NC		
35	35	Servo-Ready output	S-RDY+	35	Servo-Ready output	S-RDY+
36	NC			NC		
37	37	Servo-Alarm output	ALM+	37	Servo-Alarm output	ALM+
38	NC			NC		
39	39	Positioning complete output	COIN+	39	Speed arrival output	AT-SPEED+
40	40	Torque in-limit signal output	TLC	40	Torque in-limit signal output	TLC
41	10	External brake release signal (-)	BRK-OFF-	10	External brake release signal (-)	BRK-OFF-
	34	Positioning complete output (-)	COIN-	34	Speed arrival output (-)	AT-SPEED-
	36	Servo-Alarm output (-)	ALM-	36	Servo-Alarm output (-)	ALM-
	38	Servo-Ready output (-)	S-RDY-	38	Servo-Ready output (-)	S-RDY-
	41	Power supply for control signal (-)	COM-	41	Power supply for control signal (-)	COM-
42	42	Torque monitor output	IM	42	Torque monitor output	IM
43	43	Speed monitor output	SP	43	Speed monitor output	SP
44	25	Signal ground	GND	25	Signal ground	GND
45	25	Signal ground	GND	25	Signal ground	GND
46	25	Signal ground	GND	25	Signal ground	GND
47	NC			NC		
48	48	B-phase output	OB+	48	B-phase output	OB+
49	49	B-phase output	OB-	49	B-phase output	OB-
50	50	Frame ground	FG	50	Frame ground	FG

\* "NC" is no connect.

Pin No. on Old Model	DV0P4132		
	Pin No. on Current Model	Signal Name	Symbol
1	8	CW over-travel inhibit input	CWL
2	9	CCW over-travel inhibit input	CCWL
3	NC		
4	NC		
5	NC		
6	NC		
7	7	Power supply for control signal (+)	COM+
8	NC		
9	NC		
10	NC		
11	11	External brake release signal	BRK-OFF+
12	12	Zero-speed detection output signal	ZSP
13	13	Torque in-limit signal output	TLC
14	NC		
15	15	Signal ground	GND
16	16	Torque command input	TRQR
17	17	Signal ground	GND
18	18	CW direction torque limit input	CWTL
19	19	Z-phase output	CZ
20	NC		
21	21	A-phase output	OA+
22	22	A-phase output	OA-
23	23	Z-phase output	OZ+
24	24	Z-phase output	OZ-
25	50	Frame ground	FG
26	26	Speed zero clamp input	ZEROSPD
27	27	Gain switching input	GAIN
28	NC		
29	29	Servo-ON input	SRV-ON
30	NC		
31	31	Alarm clear input	A-CLR
32	32	Control mode switching input	C-MODE
33	NC		
34	NC		
35	35	Servo-Ready output	S-RDY+
36	NC		
37	37	Servo-Alarm output	ALM+
38	NC		
39	39	Speed arrival output	AT-SPEED+
40	40	Torque in-limit signal output	TLC
41	10	External brake release signal (-)	BRK-OFF-
	34	Speed arrival output (-)	AT-SPEED-
	36	Servo-Alarm output (-)	ALM-
	38	Servo-Ready output (-)	S-RDY-
	41	Power supply for control signal (-)	COM-
42	42	Torque monitor output	IM
43	43	Speed monitor output	SP
44	25	Signal ground	GND
45	25	Signal ground	GND
46	25	Signal ground	GND
47	NC		
48	48	B-phase output	OB+
49	49	B-phase output	OB-
50	50	Frame ground	FG

\* "NC" is no connect.

**FP7-AFP7PP02T/L(2-axes) AFP7PP04T/L(4-axes) Connection with the Panasonic devices SUNX.**

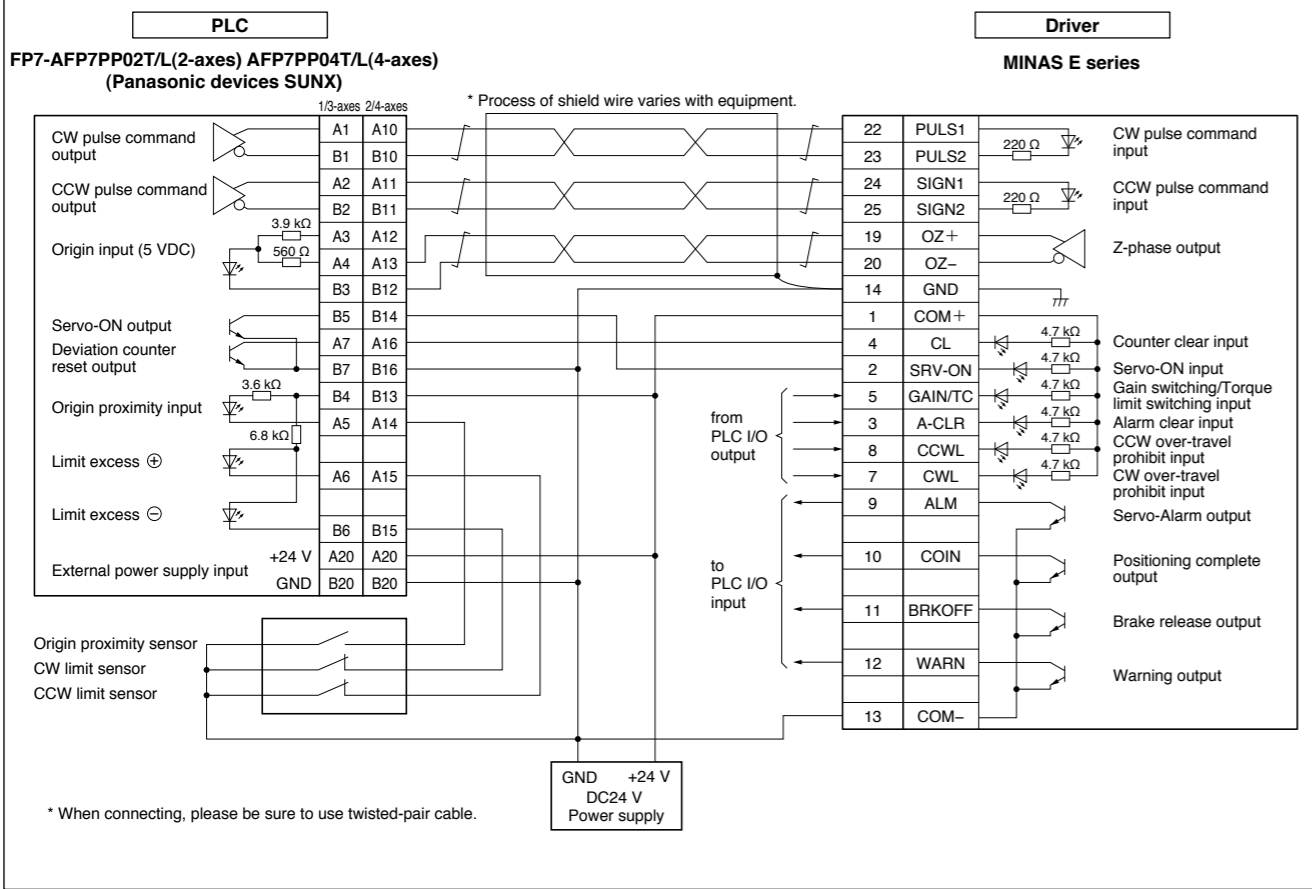

**FP2-PP2 AFP2430 Connection with the Panasonic devices SUNX.**

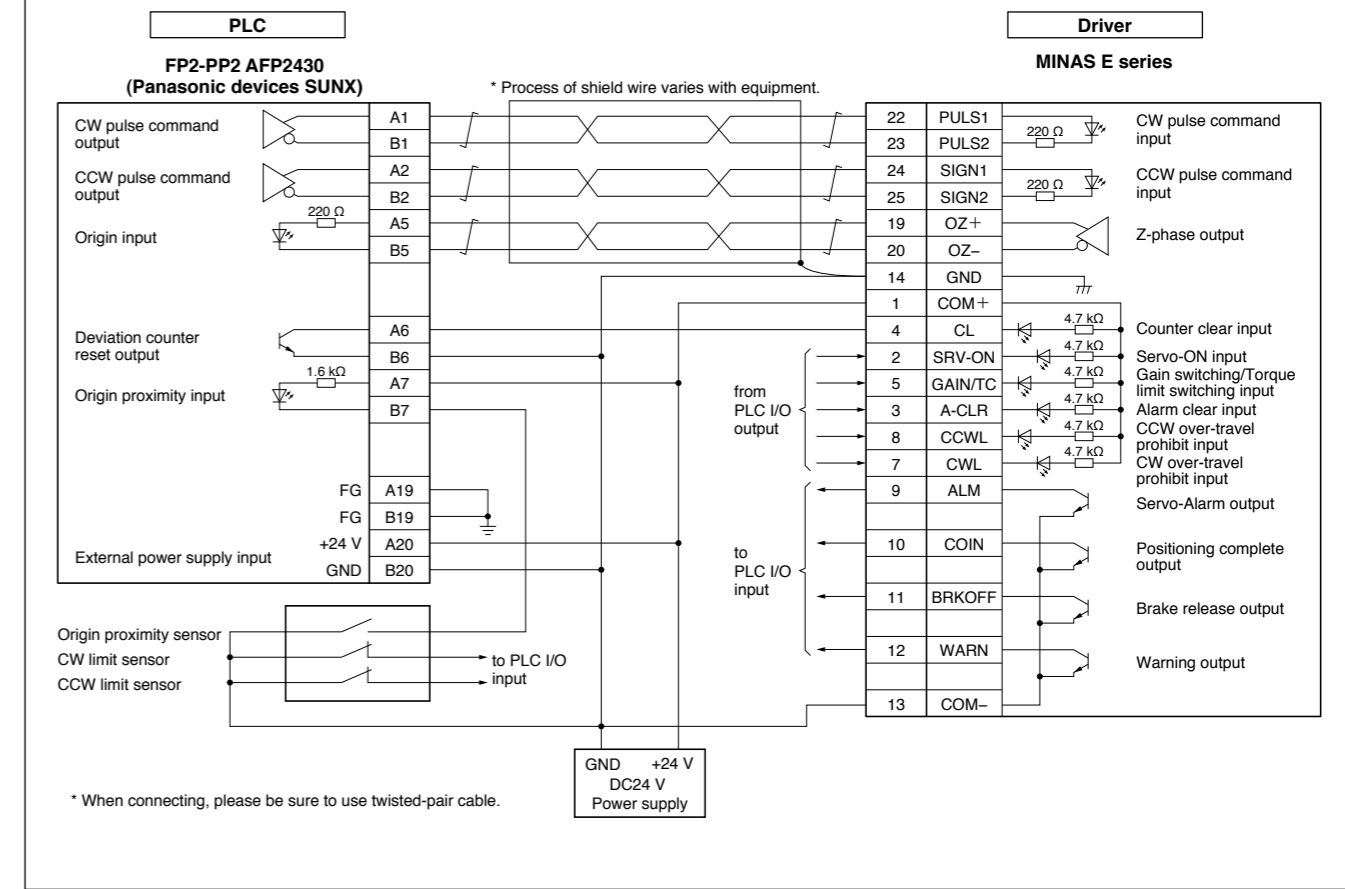

**FPG-PP12 AFPG432 Connection with the Panasonic devices SUNX.**

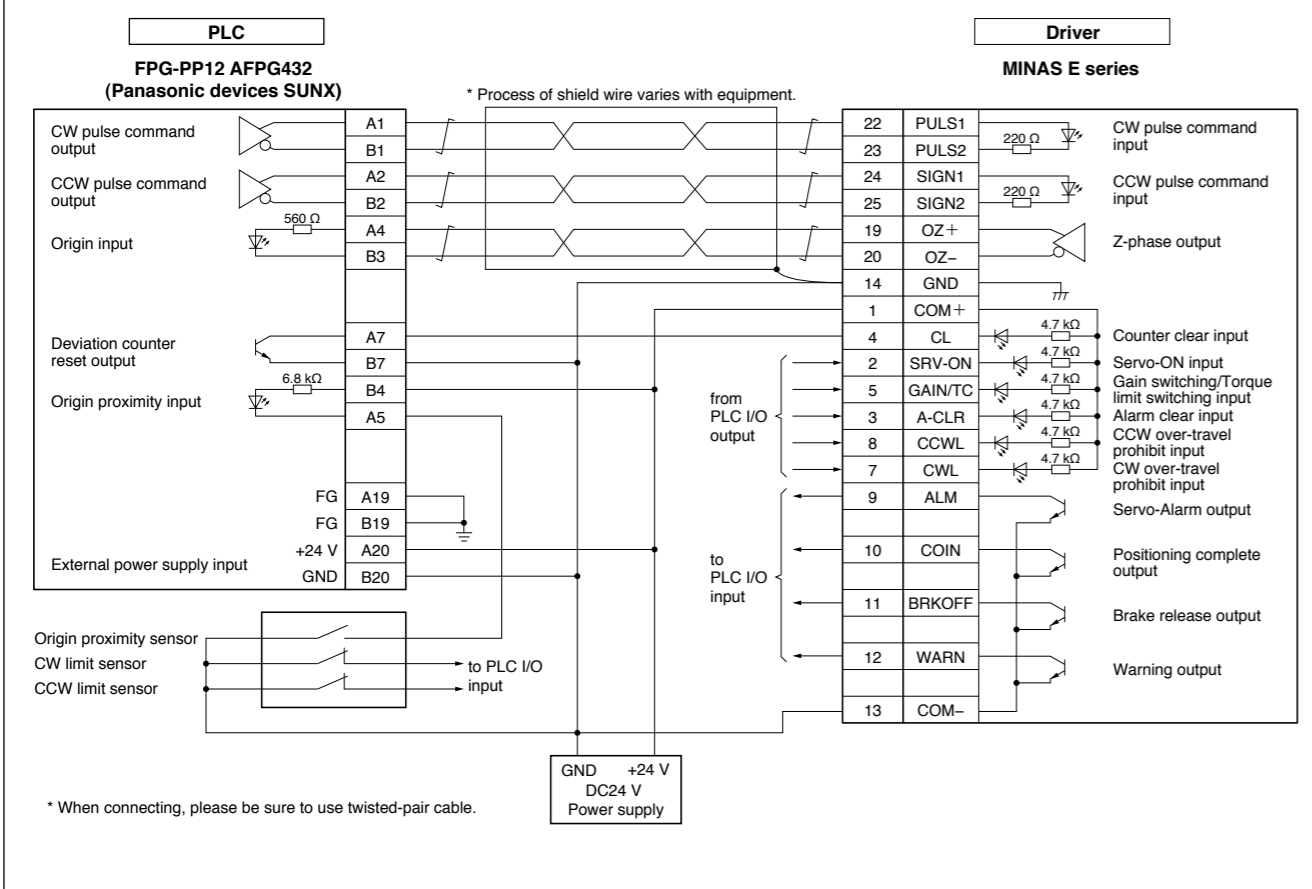

**FPG-C32T Connection with the Panasonic devices SUNX.**

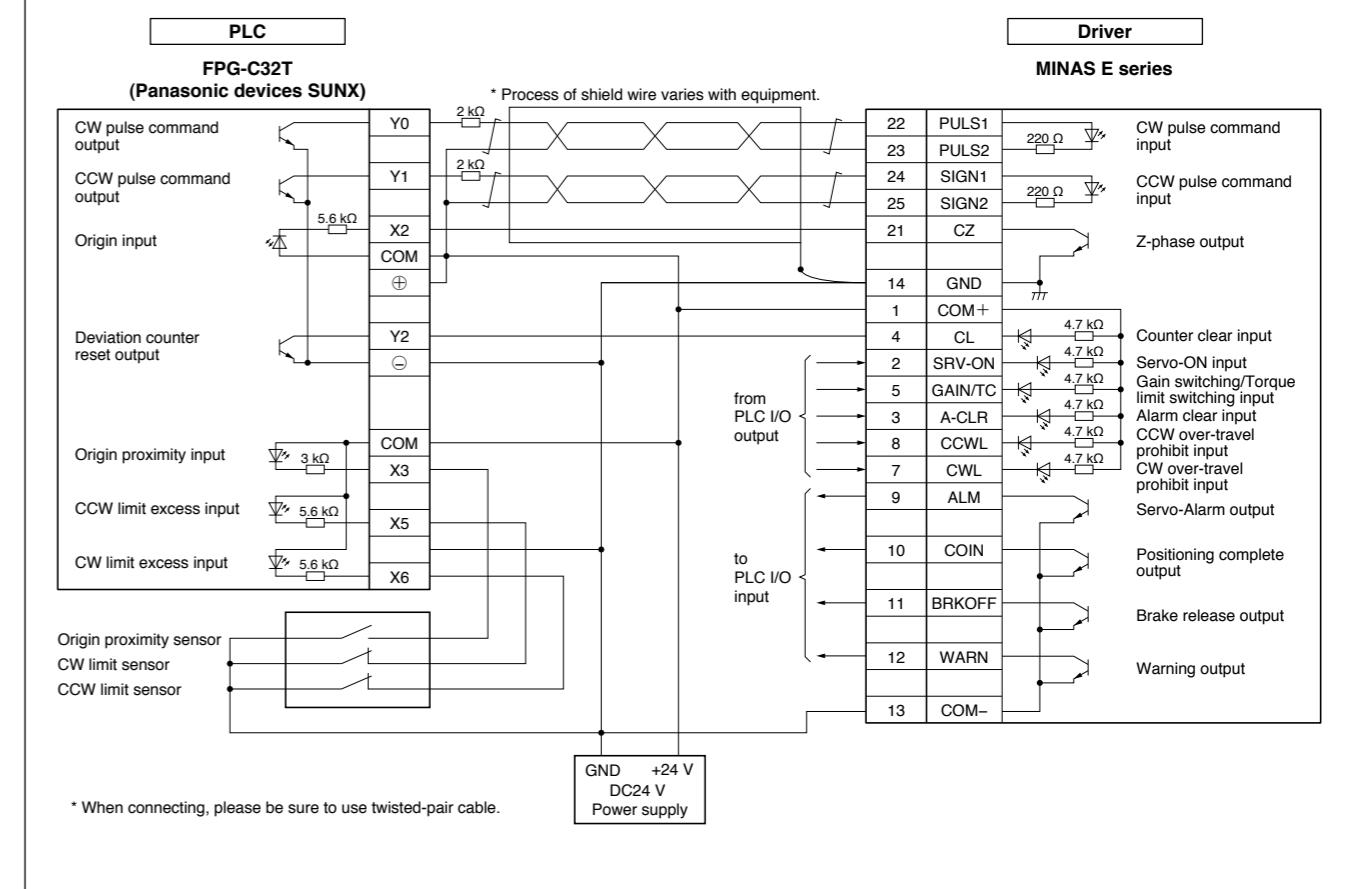



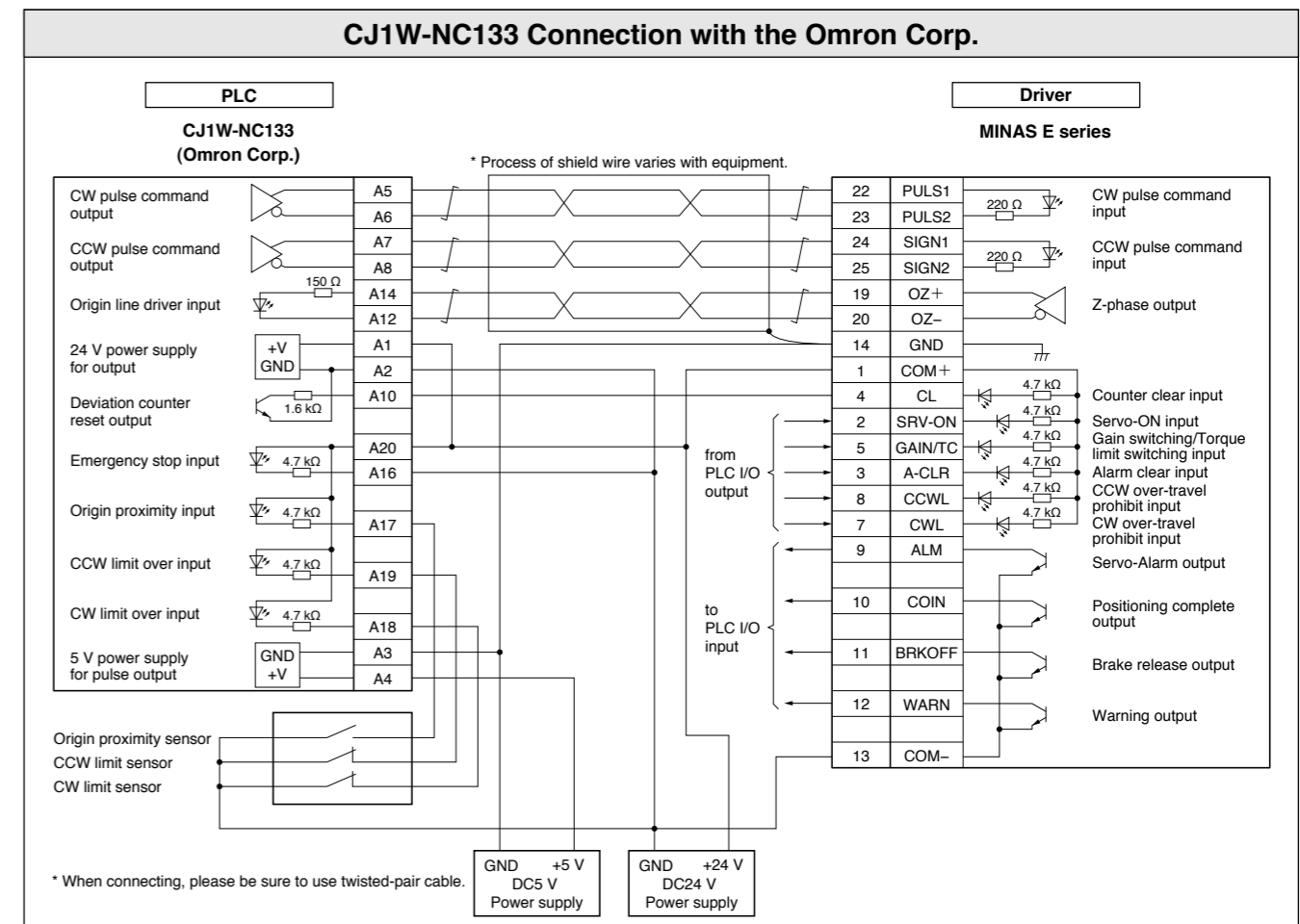
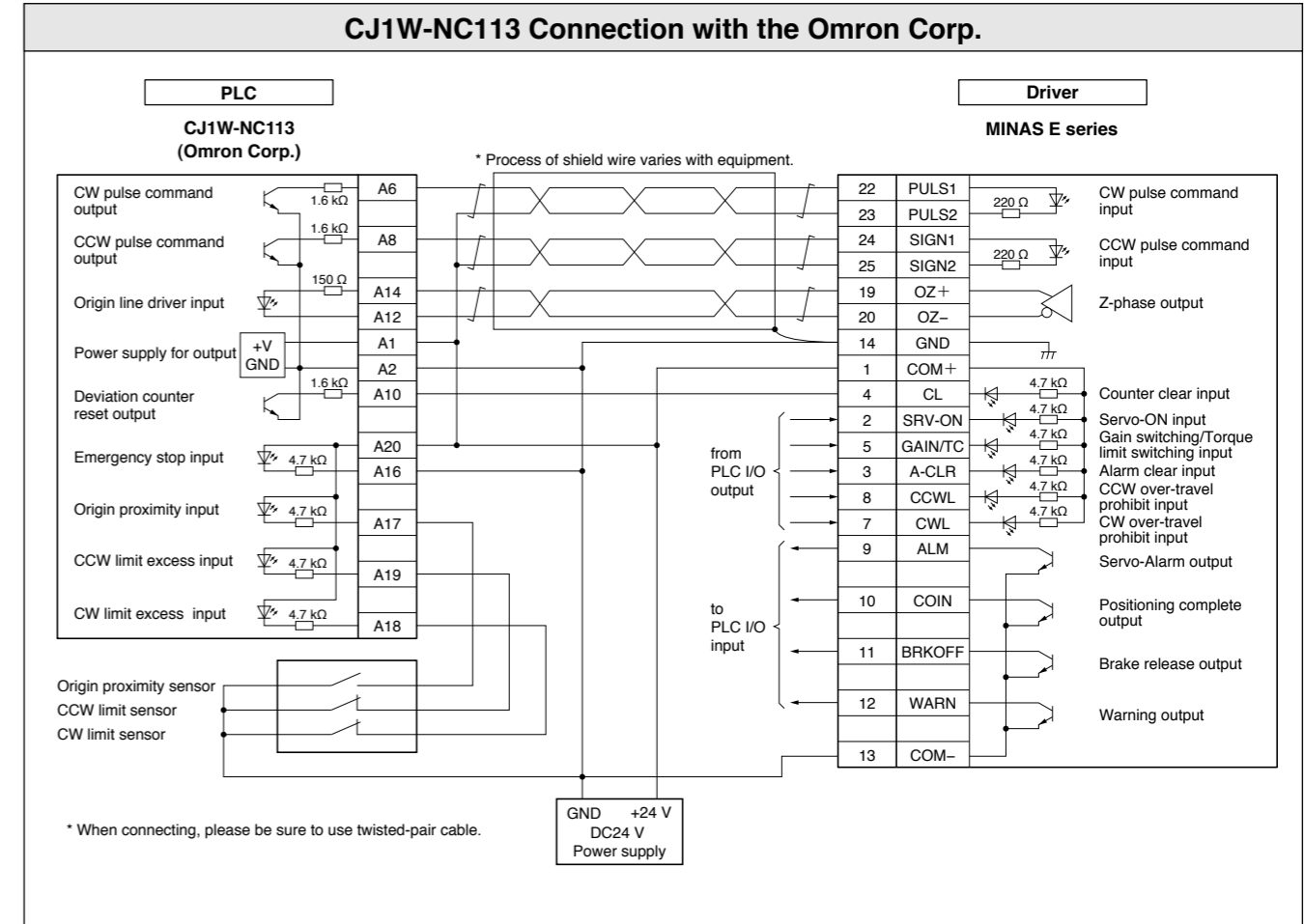
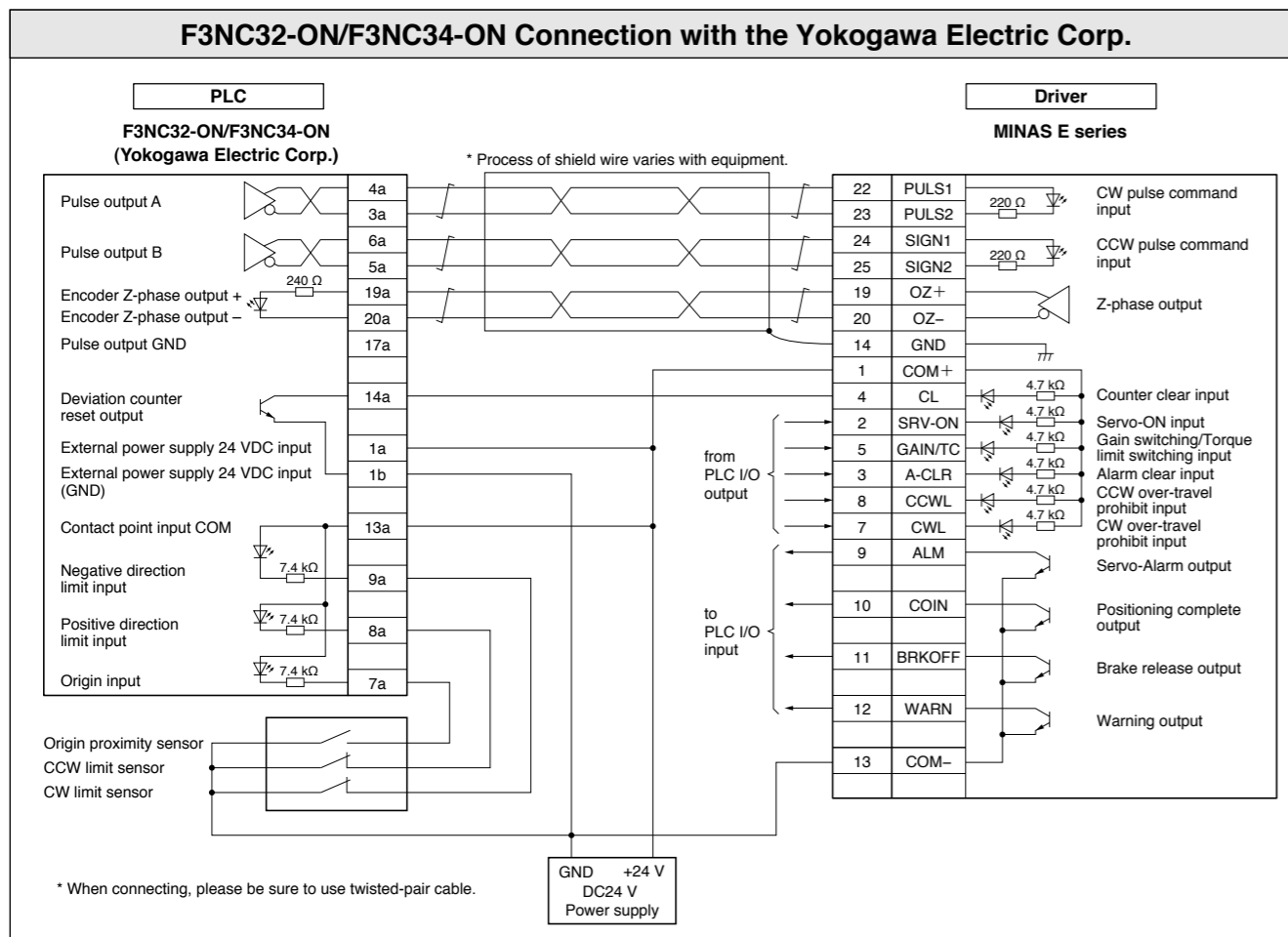
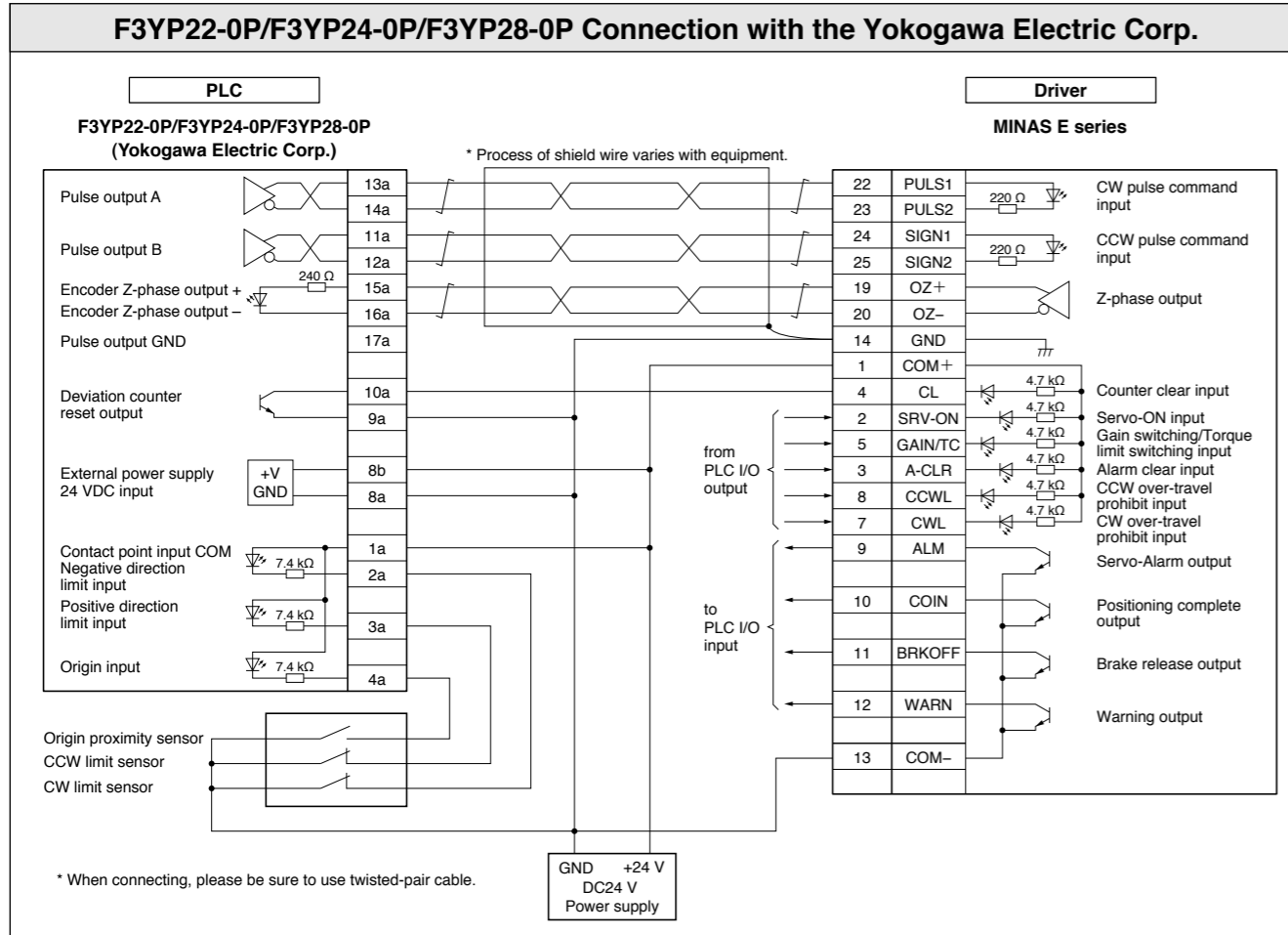

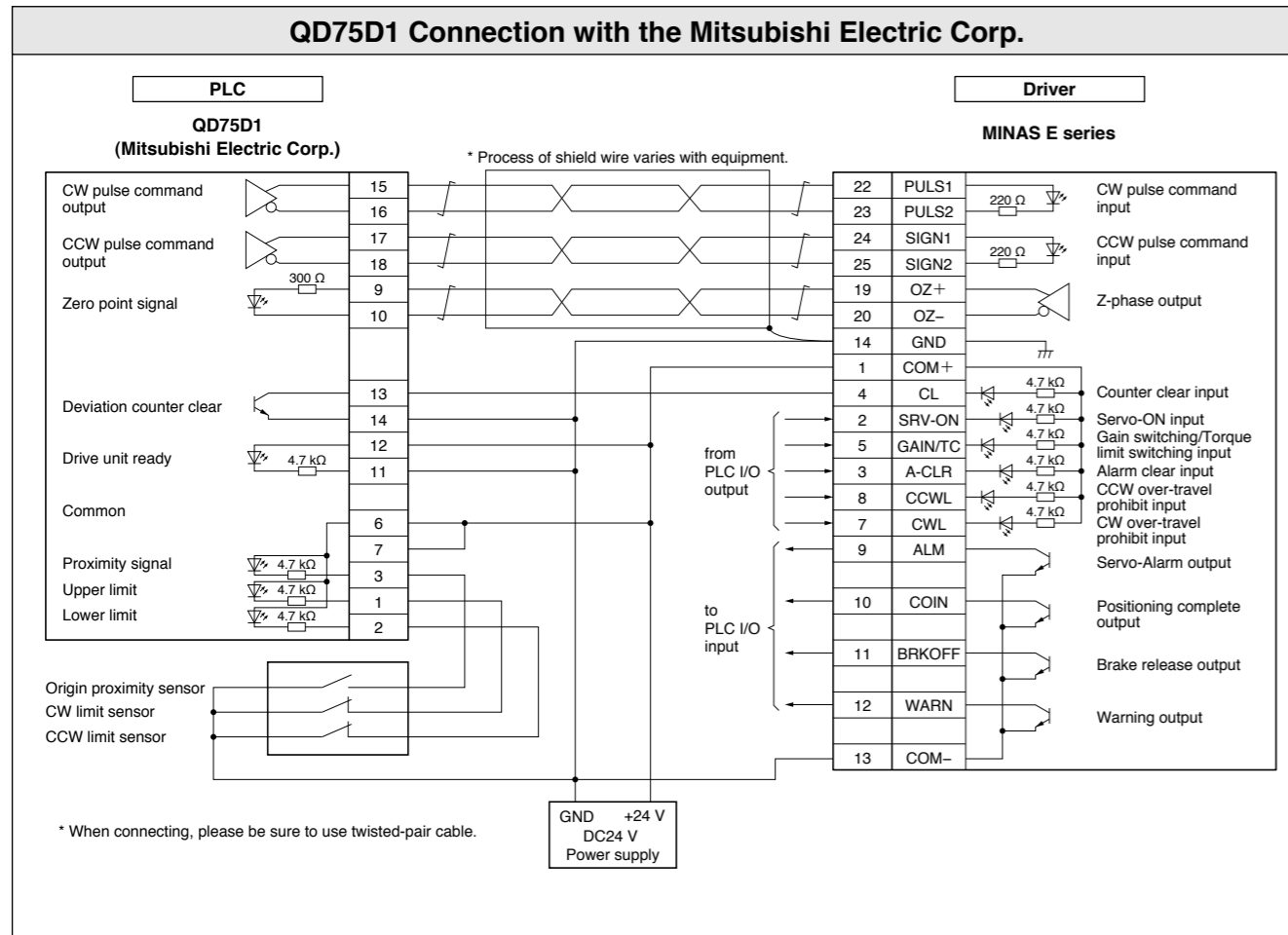

Part No.	Title	Page
DV0P0770	Connector kit for external peripheral equipment	240
DV0P0800	Interface cable	241
DV0P1450	Surge absorber (3-phase)	253,256
DV0P1460	Noise Filter for Signal Lines	254,256
DV0P1960	Communication cable	241
DV0P220	Reactor	209
DV0P221	Reactor	209
DV0P222	Reactor	209
DV0P223	Reactor	209
DV0P224	Reactor	209
DV0P225	Reactor	209
DV0P227	Reactor	209
DV0P228	Reactor	209
DV0P2870	Connector kit for power supply connection	239
DV0P2890	External regenerative resistor	242
DV0P2891	External regenerative resistor	242
DV0P2990	Battery For Absolute Encoder	207
DV0P3410	Noise Filter	251
DV0P3670	Connector kit for motor/encoder connection	239
DV0P3680	Technical reference Japanese	—
DV0P3700	Technical reference English	—
DV0P37300	Cable set (3 m)	238
DV0P3811	DIN rail mounting unit	242
DV0P39200	Cable set (5 m)	238
DV0P4120	Interface conversion cable	197
DV0P4121	Interface conversion cable	197
DV0P4130	Interface conversion cable	197
DV0P4131	Interface conversion cable	197
DV0P4132	Interface conversion cable	197
DV0P4160	Noise filter	256
DV0P4170	Noise Filter	250
DV0P4190	Surge absorber (Single phase)	253,256
DV0P4220	Noise Filter	250
DV0P4280	External Regenerative Resistor: 50 Ω 25 W	210
DV0P4281	External Regenerative Resistor: 100 Ω 25 W	210
DV0P4282	External Regenerative Resistor: 25 Ω 50 W	210
DV0P4283	External Regenerative Resistor: 50 Ω 50 W	210
DV0P4284	External Regenerative Resistor: 30 Ω 100 W	210
DV0P4285	External Regenerative Resistor: 20 Ω 130 W	210
DV0P4290	Connector Kit for Motor/Encoder Connection	202
DV0P4310	Connector Kit for Motor/Encoder Connection	204
DV0P4320	Connector Kit for Motor/Encoder Connection	204
DV0P4330	Connector Kit for Motor/Encoder Connection	205
DV0P4340	Connector Kit for Motor/Encoder Connection	205
DV0P4350	Interface Connector	198
DV0P4360	Interface cable	197
DV0P4380	Connector Kit for Motor/Encoder Connection	202
DV0P4420	Console	241
DV0P4430	Battery Box	207
DV0P4460	Setup support software "PANATERM" for MINAS series AC servo motor & Driver	236
DV0PM20010	Connector Kit: Encoder	199
DV0PM20024	Connector Kit: RS485, 232	198
DV0PM20025	Connector Kit: Safety	198
DV0PM20026	Connector Kit: External Scale	199
DV0PM20027	Mounting bracket: A-frame	208
DV0PM20028	Mounting bracket: B-frame	208
DV0PM20029	Mounting bracket: C-frame	208
DV0PM20030	Mounting bracket: D-frame	208
DV0PM20031	Connector Kit: Analog Monitor Signal	199
DV0PM20032	Connector for Power Supply Input Connection (A to D-frame (Single row type))	200
DV0PM20033	Connector for Power Supply Input Connection (A to D-frame (Double row type))	200
DV0PM20034	Connector for Motor Connection (A to D-frame)	201
DV0PM20035	Connector Kit for Motor/Encoder Connection	203
DV0PM20036	Connector Kit for Motor/Encoder Connection	203
DV0PM20037	Connector Kit for Motor/Encoder Connection	204
DV0PM20038	Connector Kit for Motor/Encoder Connection	204
DV0PM20039	Connector Kit for Motor/Encoder Connection	205
DV0PM20040	Connector Kit for Motor/Brake Connection	206
DV0PM20042	Noise Filter	250
DV0PM20043	Noise Filter	250

Part No.	Title	Page
DV0PM20044	Connector for Power Supply Input Connection (E-frame)	200
DV0PM20045	Connector for Regenerative Resistor (E-frame 200 V/400 V common)	201
DV0PM20046	Connector for Motor Connection (E-frame 200 V/400 V common)	201
DV0PM20047	Reactor	209
DV0PM20048	External Regenerative Resistor: 120 Ω 240 W	210
DV0PM20049	External Regenerative Resistor: 80 Ω 450 W	210
DV0PM20050	Surge absorber (3-phase)	253
DV0PM20051	Connector for Power Supply Input Connection (D-frame 400 V)	200
DV0PM20052	Connector for Power Supply Input Connection (E-frame 400 V)	200
DV0PM20053	Connector for Control Power Supply Input Connection (D,E-frame 400 V)	201
DV0PM20054	Connector for Motor Connection (D-frame 400V)	201
DV0PM20055	Connector for Regenerative Resistor (D-frame 400 V)	201
DV0PM20056	Connector Kit for Motor/Encoder Connection	206
DV0PM20057	Connector Kit for Motor/Encoder Connection	206
DV0PM20058	External Regenerative Resistor: 3.3 Ω 780 W	210
DV0PM20059	External Regenerative Resistor: 13.3 Ω 1140 W	210

Part No.	Title	Page
MADHT1105	A5 series Driver: A-frame	29,42
MADHT1105E	A5E series Driver: A-frame	31,42
MADHT1107	A5 series Driver: A-frame	29,42
MADHT1107E	A5E series Driver: A-frame	31,42
MADHT1505	A5 series Driver: A-frame	29,42
MADHT1505E	A5E series Driver: A-frame	31,42
MADHT1507	A5 series Driver: A-frame	29,42
MADHT1507E	A5E series Driver: A-frame	31,42

Part No.	Title	Page
MADKT1105	A5II series Driver: A-frame	29,42
MADKT1105E	A5IE series Driver: A-frame	31,42
MADKT1107	A5II series Driver: A-frame	29,42
MADKT1107E	A5IE series Driver: A-frame	31,42
MADKT1505	A5II series Driver: A-frame	29,42
MADKT1505E	A5IE series Driver: A-frame	31,42
MADKT1507	A5II series Driver: A-frame	29,42
MADKT1507E	A5IE series Driver: A-frame	31,42

Part No.	Title	Page
MBDHT2110	A5 series Driver: B-frame	29,42
MBDHT2110E	A5E series Driver: B-frame	31,42
MBDHT2510	A5 series Driver: B-frame	29,42
MBDHT2510E	A5E series Driver: B-frame	31,42

Part No.	Title	Page
MBDKT2110	A5II series Driver: B-frame	29,42
MBDKT2110E	A5IE series Driver: B-frame	31,42
MBDKT2510	A5II series Driver: B-frame	29,42
MBDKT2510E	A5IE series Driver: B-frame	31,42

Part No.	Title	Page
MCDHT3120	A5 series Driver: C-frame	29,43
MCDHT3120E	A5E series Driver: C-frame	31,43
MCDHT3520	A5 series Driver: C-frame	29,43
MCDHT3520E	A5E series Driver: C-frame	31,43

Part No.	Title	Page
MCDKT3120	A5II series Driver: C-frame	29,43
MCDKT3120E	A5IE series Driver: C-frame	31,43



















## [Panasonic Sales Office of Motors]

(June.01.2013)

Country	Company Name	City	Address	TEL
				FAX
North America	Panasonic Industrial Devices Sales Company of America (PIDSA)	New Jersey	Three Panasonic Way, 7E-2 Secaucus, NJ 07094 U.S.A.	+1-201-348-5356 +1-201-392-4315
	Panasonic Electric Works Corporation of America (PEWA)	New Jersey	629 Central Avenue New Providence, NJ 07974 U.S.A.	+1-908-464-3550 Technical Support: +1-877-624-7872 +1-908-771-5655
Brazil	Panasonic Electric Works Corporation of America Brazil Rep. Office	Sao Paulo	Rua Cubatao, 320- 8 andar-Paraiso, CEP 04013-001 Sao Paulo-SP	+55-11-3889-4006 +55-11-3889-4103
Spain	Panasonic Electric Works Espana S.A.	Madrid	Barajas Park, San Severo 20, 28042 Madrid, Spain	+34-91-329-3875 +34-91-329-2976
Germany	Panasonic Industrial Devices Sales Europe GmbH	Munich	Hans-Pinsel-Strasse 2 · D - 85540 Haar · Germany	+49-89-46-159-0 +49-89-46-159-212
Italy	Panasonic Electric Works Italia srl	Verona	Via del Commercio 3-5 (Z.I.Ferlina), 37012 Bussolengo (VR), Italy	+39-045-6752711 +39-045-6700444
Russia	Electroprivod Ltd. (*Distributors)	St.Petersburg	Office 316, litera 43, Polustrovskiy avenue, Saint-Petersburg, Russia. Website: <a href="http://www.electroprivod.ru">http://www.electroprivod.ru</a>	+ 7-812-703-09-81 + 7-812-493-27-26
China	Panasonic Shun Hing Industrial Devices Sales (Hong Kong) Co.,Ltd. (PSIDSHK)	Hong kong	Level 33, Office Tower, Langham Place, 8 Argyle Street, Mongkok, Kin.,Hong Kong	+852-2529-7322 +852-2598-9743
	Panasonic Industrial Devices Sales (China) Co.,Ltd. (PIDSCN)	Shanghai	Floor 7, China Insurance Building, 166 East Road LuJiaZui PuDong New District, Shanghai, China	+86-21-3855-2442 +86-21-3855-2375
	Panasonic SH Industrial Devices Sales (Shenzhen) Co.,Ltd. (PSIDSSZN)	Shenzhen	8/F, Tower Three, Kerry Plaza, 1-1 Zhongxinsi Road, Futian District, Shenzhen, China	+86-755-8255-8551 +86-755-8255-8668
India	Panasonic Industrial Devices Sales India (PIDSIN) (A division company of Panasonic India Pvt Ltd.)	Haryana	7th Floor, ABW Tower, IFFCO Chowk, MG Road, Sector 25, Gurgaon-122 001, Haryana, India	+91-124-4596600 +91-124-4596625
	Lubi Electronics (*Distributors)	Gandhinagar/Ahmedabad	Sardar Patel Ring Road, Nr. Bright School, Nana Chiloda. Dist.: Gandhinagar - 382 325. Gujarat, India <a href="http://www.lubielelectronics.com">http://www.lubielelectronics.com</a>	+91-79-39845300 +91-79-39845599
	Luna Bearings, Automation & Power Transmission (*Distributors)	Mumbai	59, Bibijan Street, 2nd Floor, Mumbai- 400 003, India <a href="http://www.lunabearings.com">http://www.lunabearings.com</a>	+91-22-40786110 +91-22-23455052 +91-22-23427773
	Vashi Electricals Pvt. Ltd. (*Distributors)	Mumbai	A/6, Plot No.74, Shree Ganesh Complex, Behind Gupta Compound, Dapode Road, Mankoli Naka, Tal: Bhiwandi- 421305, Mah - India <a href="http://www.vashielectricals.com">http://www.vashielectricals.com</a>	+91-2522-661600 +91-2522-661620 +91-2522-661634 +91-2522-661669
Korea	Panasonic Industrial Devices Sales Korea Co., Ltd. (PIDSKR)	Seoul	14F, West-gate Bldg, 332 Migeun-dong, Seodaemun-gu, Seoul, 120-020, Korea	+82-2-795-9600 +82-2-795-1542

Country	Company Name	City	Address	TEL
				FAX
Taiwan	Panasonic Industrial Devices Sales Taiwan Co.,Ltd.	Taipei	12F, No.9, SongGao Rd., Taipei 110, Taiwan, R.O.C.	+886-2-2757-1900 +886-2-2757-1977
Singapore	Panasonic Industrial Devices Sales Asia Pte. Ltd.	Singapore	300 Beach Road #16-01 The Concourse Singapore 199555	+65-6390-3718 +65-6390-3801
	Intermech Machinery Pte Ltd. (*Distributors)	Singapore	2 Woodlands Sector 1 #03-25, Woodlands Spectrum 1 Singapore 738068 Website: <a href="http://www.intermech.com.sg">http://www.intermech.com.sg</a>	+65-6751-5088 +65-6759-2122
Malaysia	Panasonic Industrial Devices Sales Asia Pte. Ltd.	Singapore	300 Beach Road #16-01 The Concourse Singapore 199555	+65-6390-3718 +65-6390-3801
	Panamech Machinery Sdn Bhd (*Distributors)	Kuala Lumpur	No.14, Lorong Sanggul 1C, Bandar Puteri, 41200 Klang, Selangor Darul Ehsan Website: <a href="http://www.panamech.com.my">http://www.panamech.com.my</a>	+60-3-5161-7876 +60-3-5161-7136
	Panamech (PG) Sdn Bhd (*Distributors)	Penang	Sri Relau Komplex, Unit 1-3-11, Persiaran Bukit Jambul 1, 11900 Penang Website: <a href="http://www.panamech.com.my">http://www.panamech.com.my</a>	+60-4-643-8266 +60-4-645-1639
Thailand	Panasonic Industrial Devices Sales Asia Pte. Ltd.	Singapore	300 Beach Road #16-01 The Concourse Singapore 199555	+65-6390-3718 +65-6390-3801
	Premier Automation Center Co.,Ltd. (*Distributors)	Bangkok	73 Soi Ladkrabang 30 Ladkrabang Ladkrabang Bangkok 10520 Website: <a href="http://www.premier-ac.co.th">http://www.premier-ac.co.th</a>	+66-2181-2299 +66-2181-2288
	Plenty Island (Thai) Co.,Ltd. (*Distributors)	Bangkok	3 Soi Charoenrat 10, Charoenrat Road., Bangkhlo, Bangkhorlaem, Bangkok 10120 Website: <a href="http://www.plenty.co.th">http://www.plenty.co.th</a>	+66-2291-9933 +66-2291-2065
	Seng Charoen Muang Co.,Ltd. (*Distributors)	Bangkok	12/349 Moo 15, Bangkaew, Bangplee, Samutprakam 10540 Website: <a href="http://www.sengscm.com">http://www.sengscm.com</a>	+66-2397-9577 +66-2361-8207
Indonesia	Panasonic Industrial Devices Sales Asia Pte. Ltd.	Singapore	300 Beach Road #16-01 The Concourse Singapore 199555	+65-6390-3718 +65-6390-3801
	PT. Handal Yesindo Sejahtera (*Distributors)	Surabaya	Jl. Raya Kutisari 8A, Surabaya, Indonesia Website: <a href="http://www.handalyesindo.com">http://www.handalyesindo.com</a>	+62-31-843-8844 +62-31-841-4333
	PT.Riasarana Electrindo (*Distributors)	Jakarta	Jl. Prof. Dr. Latumenten Grogol Permai blok D No. 8-15 Jakarta 11460, Indonesia Website: <a href="http://www.risacorps.com">http://www.risacorps.com</a>	+62-21-564-9178 +62-21-566-7405